



YOUR NAME HERE

1256

DEVOTED TO BEAUTIFUL

1256 Yonge Street

Main Floor and Lower Level

GILLEN

PROPERTY DETAILS

Main Level: 1791 square feet

Lower level 1500 square feet

Price: Main floor @ \$45 psf net and
lower level @ 10 psf net

TMI
\$12.34 psf

Possession
May 30th, 2020 or TBA

Features
Steps from Summerhill Subway
station, service shops and
restaurants
Attractive and spacious
retail/studio space
One car on-site parking
included in rent

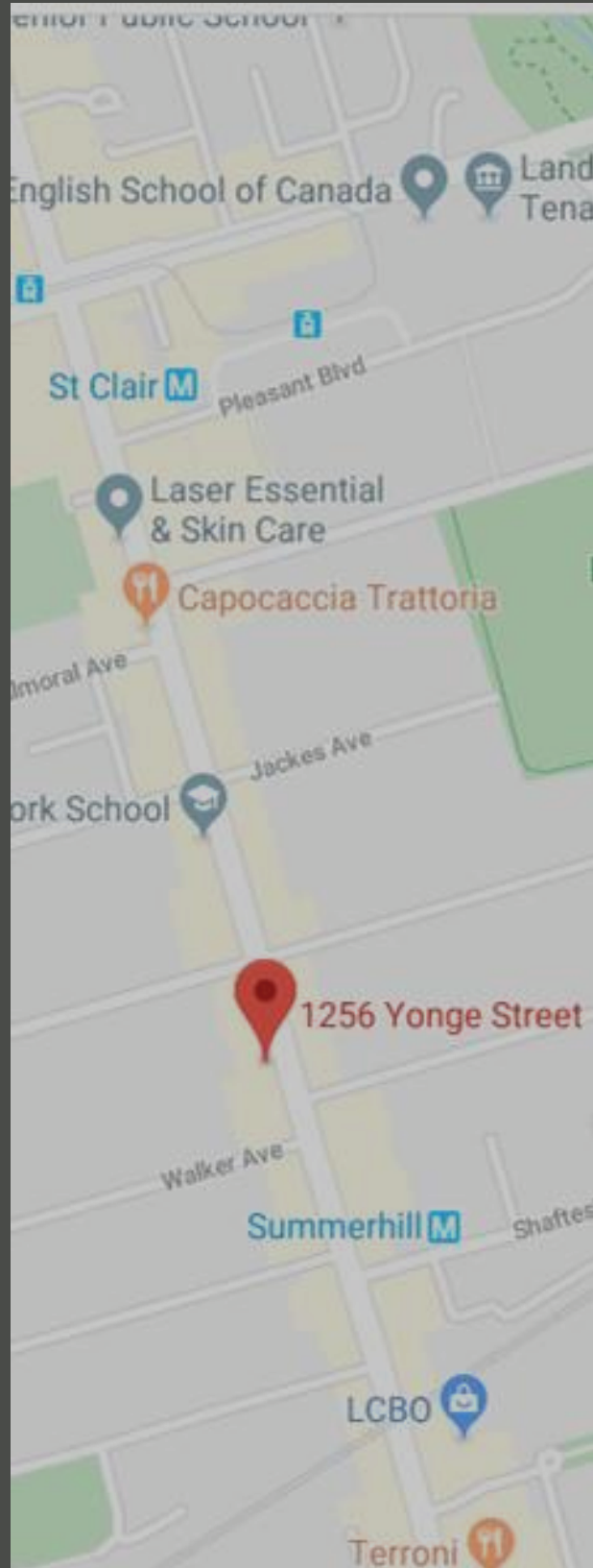

1256 YONGE STREET Main and Lower

FLOOR PLANS

1256 Yonge Street
Lower Level

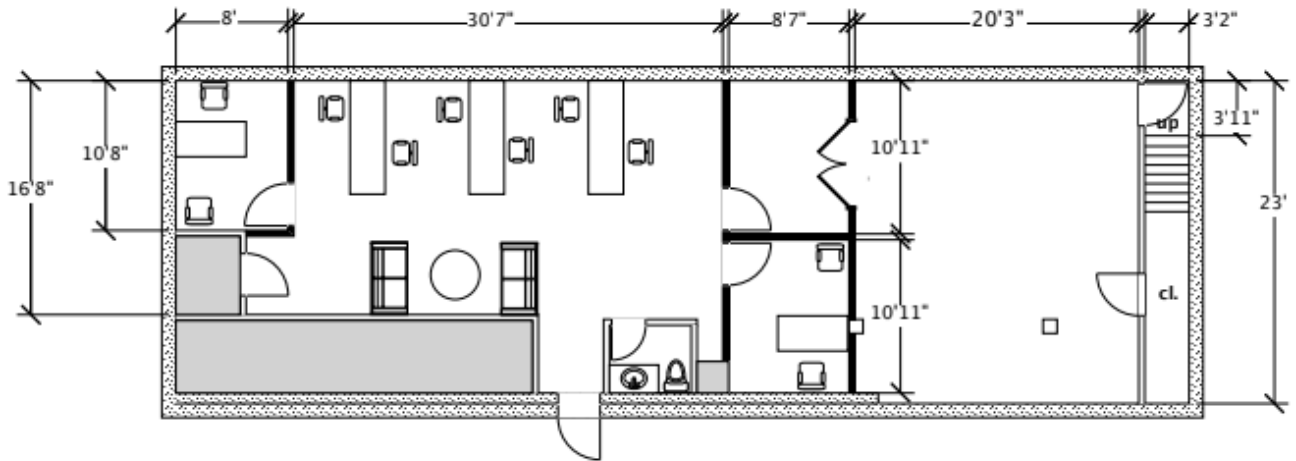

1256 Yonge Street
Toronto, Canada M4T 1W5

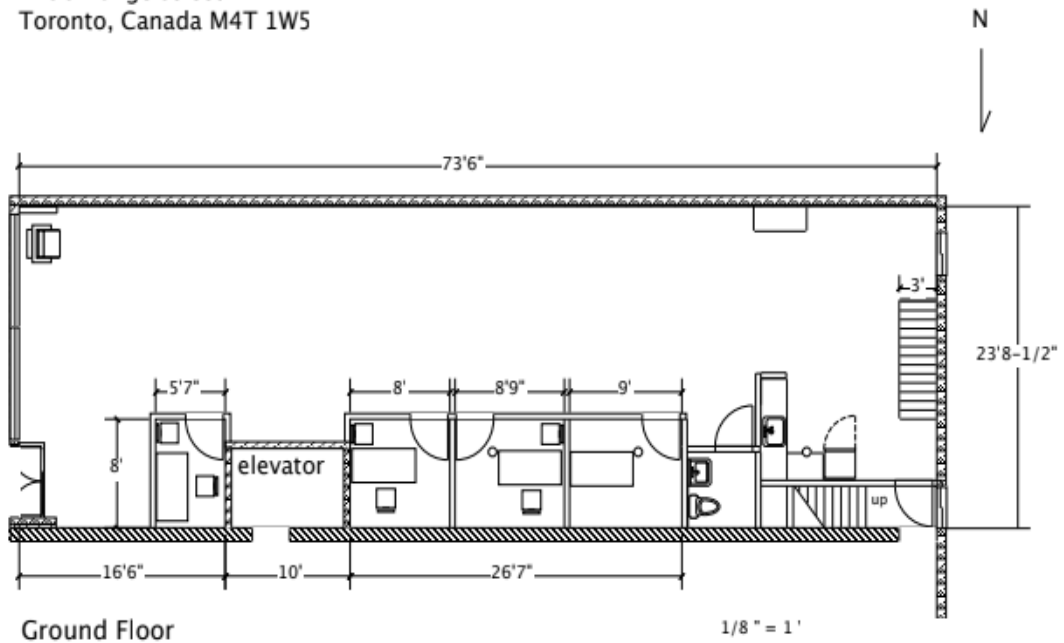

Ground Floor

1/8" = 1'

GILLEN

K.P. GILLEN & CO. REALTY LTD.
BROKERAGE
40 Scollard Street Suite 200
Toronto, ON M5R 3S1
(416) 964 9441
www.kpgillen.com

KEVIN P. GILLEN
FRI, BROKER, PRESIDENT
(416) 964 9460
Kevin@kpgillen.com

Although K.P. GILLEN & CO. REALTY LTD. attempts to ensure that all information provided is accurate and complete, we do not represent that it is so, or guarantee it, and accept no liability or obligation for accuracy or completeness. If there is any discrepancy between information posted on our website and in an original paper version, the version that is most current should be considered to be the authoritative version.

1256 Yonge Street-Main Floor

PHOTOS

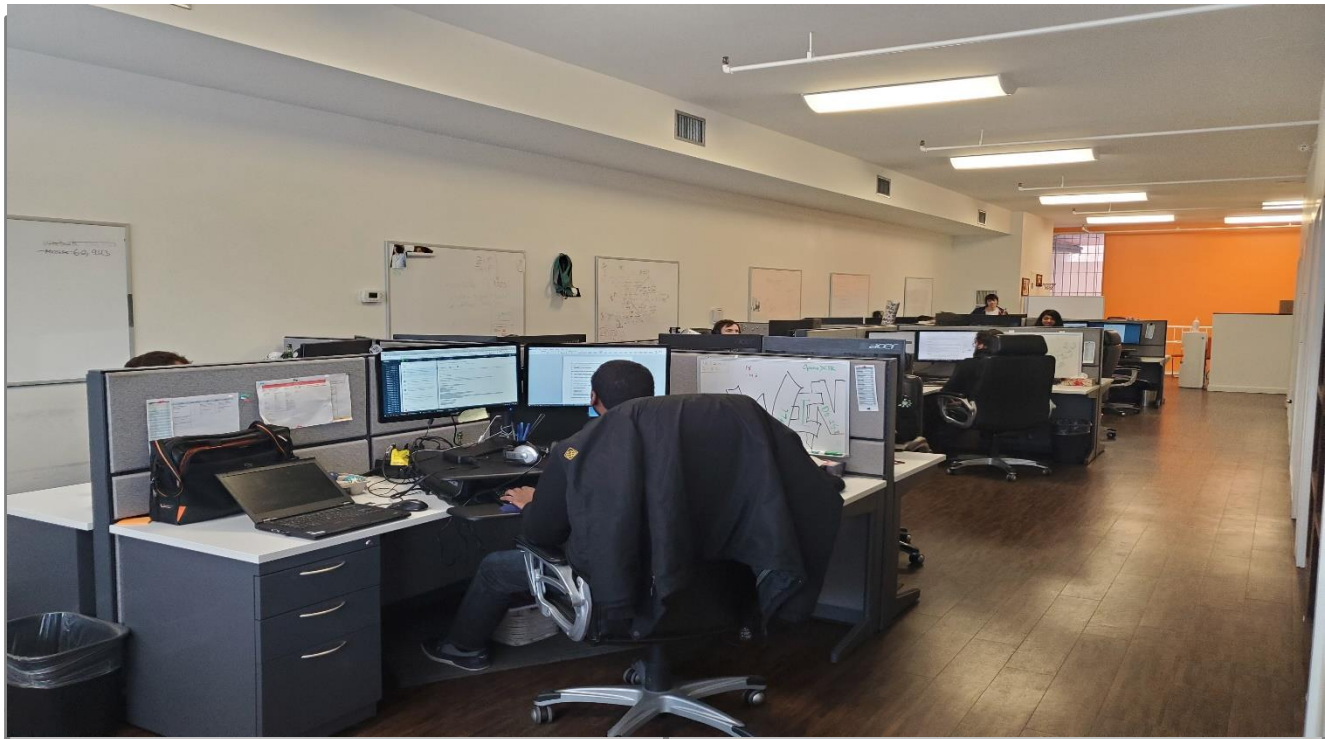

GILLEN

40 Scollard Street Suite 200
Toronto, ON M5R 3S1
(416) 964 9441
www.kpgillen.com

(416) 964 9460
Kevin@kpgillen.com

Although K.P. GILLEN & CO. REALTY LTD. attempts to ensure that all information provided is accurate and complete, we do not represent that it is so, or guarantee it, and accept no liability or obligation for accuracy or completeness. If there is any discrepancy between information posted on our website and in an original paper version, the version that is most current should be considered to be the authoritative version.

1256 Yonge Lower Level

PHOTOS



GILLEN

K.P. GILLEN & CO. REALTY LTD.
BROKERAGE
40 Scollard Street Suite 200
Toronto, ON M5R 3S1
(416) 964 9441
www.kpgillen.com

KEVIN P. GILLEN
FRI, BROKER, PRESIDENT
(416) 964 9460
Kevin@kpgillen.com

Although K.P. GILLEN & CO. REALTY LTD. attempts to ensure that all information provided is accurate and complete, we do not represent that it is so, or guarantee it, and accept no liability or obligation for accuracy or completeness. If there is any discrepancy between information posted on our website and in an original paper version, the version that is most current should be considered to be the authoritative version.