

YORI

DO IT YOURSELF WITH THE GYOMU LADDER DESK (MINI)

THESE ARE ALL THE PARTS INCLUDED IN THE BOX.

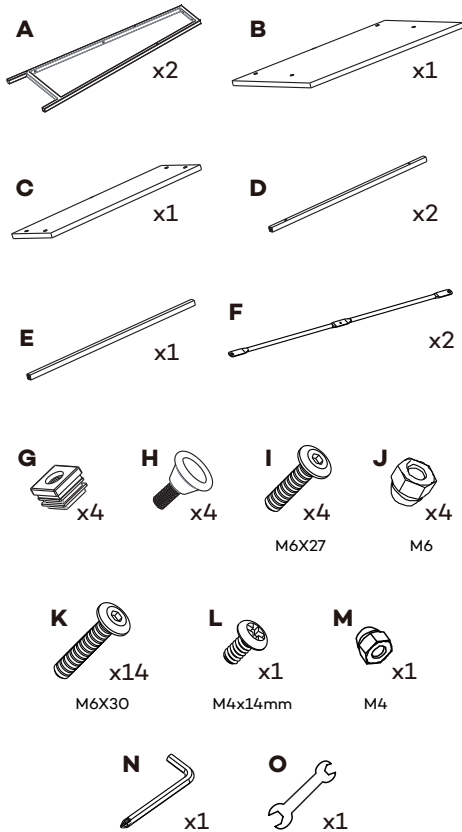

STEP 1 Insert the square tube insert^(G) to the bottom of the desk legs.
Screw-in the leveling feet^(H) to the bottom of the desk legs.

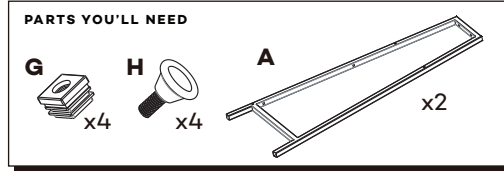

HERE'S HOW...

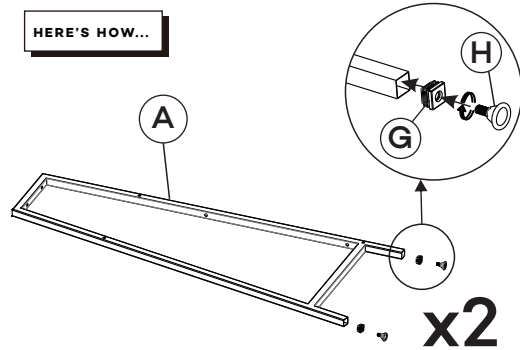

STEP 2 Screw-in the bars^(D) to the bottom of the table top^(B).

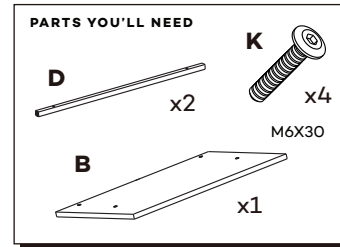

HERE'S HOW...

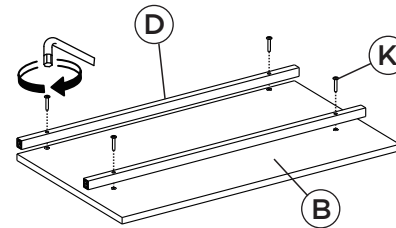

STEP 3 Screw-in all the ends^(K) of the bars to the table legs.
Screw-in both ends of the spindle^(E) to the table legs.

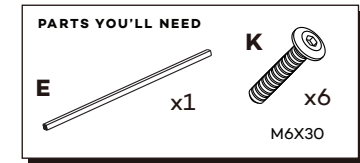

HERE'S HOW...

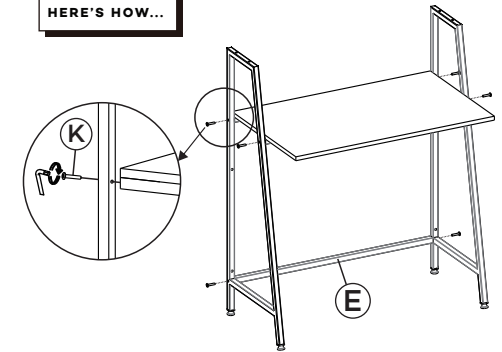

STEP 4 Screw-in together the pair of braces^(F) to make a cross brace.

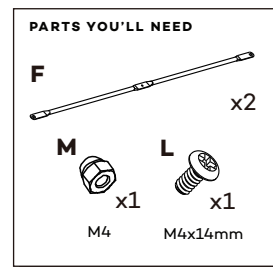

HERE'S HOW...

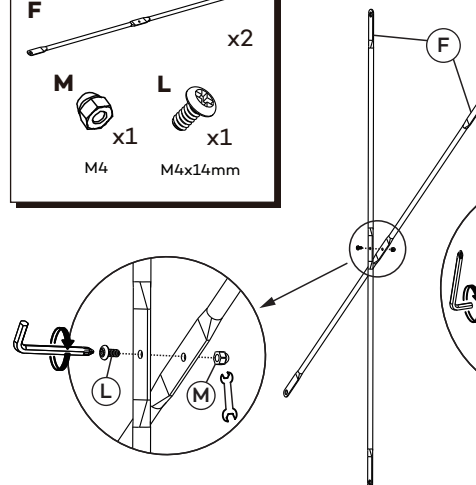

STEP 5 Screw-in^(I) the cross brace to the back of the table legs.

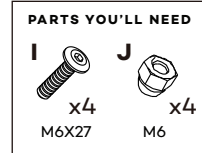

HERE'S HOW...

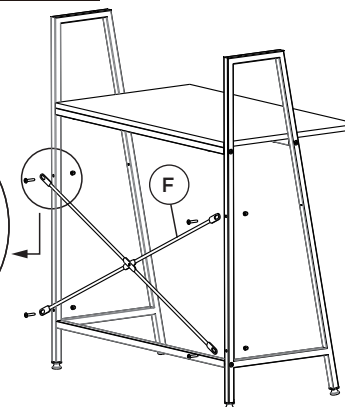

STEP 6 Screw in the top shelf^(C) to the top of the desk legs.

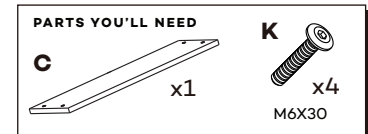

HERE'S HOW...

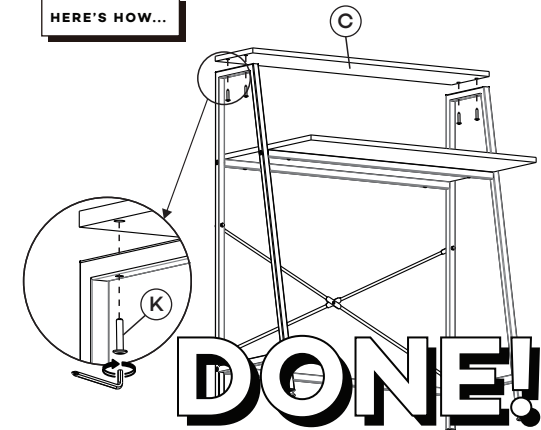

DONE!