

MICA Plus

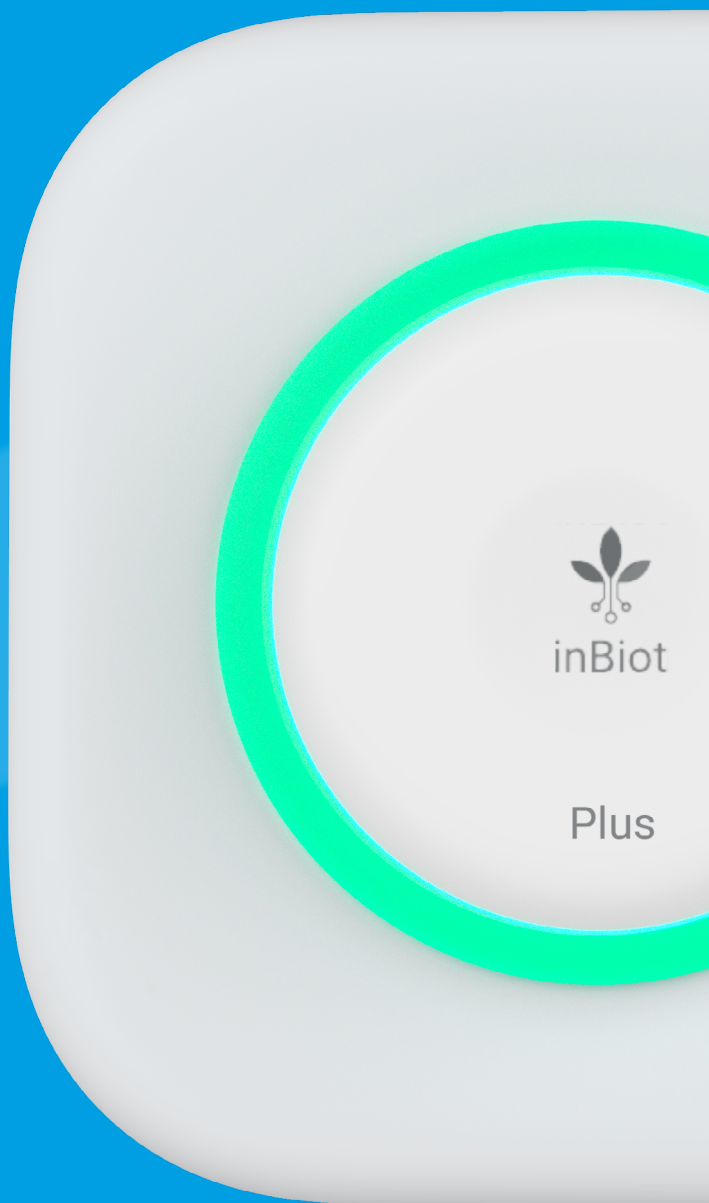



Features

Multifunction touch button.

Status LED light ring.

USB type C connector.

Wi-Fi connection.*

Dimensions and weight

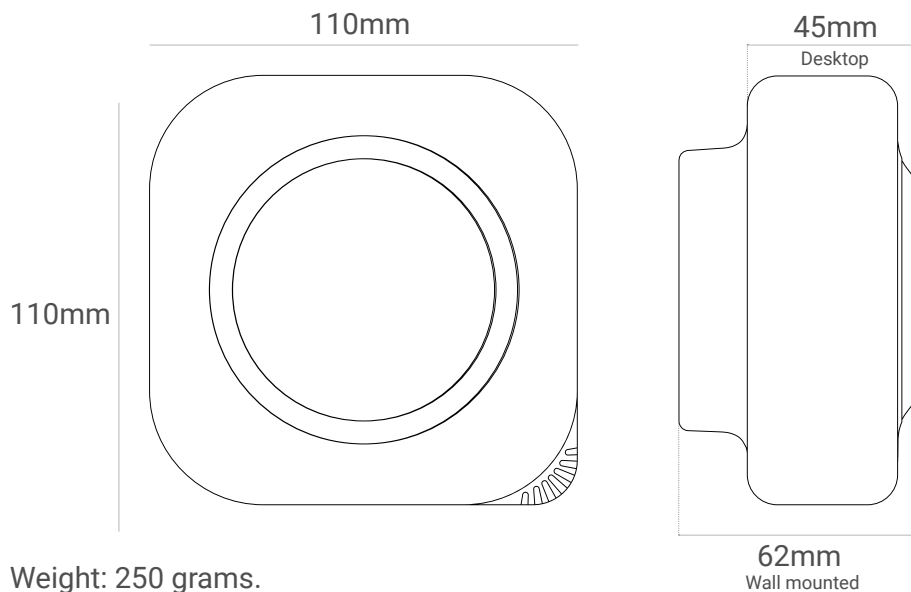

Weight: 250 grams.

Power Supply Options

USB type C cable + 5V USB power adapter (desktop only).

Fast 110 - 240V AC 50-60 Hz 0.2A connector.

Fast 8 - 36V DC 2A 10W connector.

Connectivity Options

LoRaWAN.

Sigfox.

NB-IoT / LTE-M.

Local Communication Options

Modbus RTU (RS-485).

Modbus TCP/IP (wireless) .

API.

MQTT.

*The device can only connect to 2.4 GHz WiFi networks. 5GHz WiFi networks are not supported.
Supported authentication and security protocols: WPA2 (Personal), WPA2 Enterprise, WPA3 (Personal), and WPA3 Enterprise.



Temperature

Sensor: Silicon bandgap / Unit: °C
Range: -40 - 145 °C / Resolution: 0,1 °C
Accuracy: ± 0,5 °C
Lifespan¹: >10 years

Relative Humidity

Sensor: Capacitive / Unit: %RH
Range: 0 - 100 %RH / Resolution: 1 %RH
Accuracy: ± 2 %RH
Lifespan: >10 years

CO₂

Sensor: NDIR / Unit: ppm
Range: 400 - 10.000 ppm / Resolution: 1ppm
Accuracy: ±(30 + 3% m.v.) ppm
Lifespan: >10 years

TVOC

Sensor: MOx / VOC Index Points (µg/m³ / ppm)*
Range: 0 - 500 VOC Index Points / Resolution: 1 VOC Index Points
Accuracy: ±15 VOC Index points or ±15% m.v., whichever is larger
Lifespan: >10 years

PM_{2,5}

Sensor: Particle laser / Unit: µg/m³
Range: 0 - 1.000 µg/m³ / Resolution: 1 µg/m³
Accuracy: ± (5 µg/m³ + 5% m.v.) (0 -100 µg/m³), ±10% m.v. (101-1000 µg/m³)
Lifespan: >10 years

PM₁₀

Sensor: Particle laser / Unit: µg/m³
Range: 0 - 1.000 µg/m³ / Resolution: 1 µg/m³
Accuracy: ±25 µg/m³ (0 -100 µg/m³), ±25% m.v. (101 - 1000 µg/m³)
Lifespan: >10 years

[1] Lifespan is based on the average lifetime of the sensor, at which the specified accuracy is guaranteed. After the indicated years, it is recommended to replace the sensor to guarantee the accuracy of the measurement.

* The measurements can be displayed in either relative Index Points values (recommended) or in µg/m³ or ppb concentrations. You can select the option that best suits you from My inBiot. [More information.](#)



PM_{4,0}

Sensor: Particle laser / Unit: $\mu\text{g}/\text{m}^3$

Range: 0 - 1.000 $\mu\text{g}/\text{m}^3$ / Resolution: 1 $\mu\text{g}/\text{m}^3$

Accuracy: $\pm 25 \mu\text{g}/\text{m}^3$ (0 -100 $\mu\text{g}/\text{m}^3$), $\pm 25\%$ m.v. (101 - 1000 $\mu\text{g}/\text{m}^3$)

Lifespan: >10 years

PM_{1,0}

Sensor: Particle laser / Unit: $\mu\text{g}/\text{m}^3$

Range: 0 - 1.000 $\mu\text{g}/\text{m}^3$ / Resolution: 1 $\mu\text{g}/\text{m}^3$

Accuracy: $\pm (5 \mu\text{g}/\text{m}^3 + 5\% \text{ m.v.})$ (0 -100 $\mu\text{g}/\text{m}^3$), $\pm 10\%$ m.v. (101-1000 $\mu\text{g}/\text{m}^3$)

Lifespan: >10 years

Formaldehyde

Sensor: Electrochemical / Unit: ppb

Range: 0 - 1000 ppb / Resolution: 1 ppb

Accuracy: $\pm 20 \mu\text{g}/\text{m}^3$ or $\pm 20\%$ m.v., whichever is larger

Lifespan: >6 years

[1] Lifespan is based on the average lifetime of the sensor, at which the specified accuracy is guaranteed. After the indicated years, it is recommended to replace the sensor to guarantee the accuracy of the measurement.



1. To install and configure your MICA, please refer to the documentation in the [Support](#) page of our website.

2. Some sensors require preheating so they may not display data for the first few minutes or hours after powering up.

3. During the first 24 hours after connecting the MICA, ensure that clean ambient air concentration values are reached through proper ventilation to ensure optimal initial calibration.

4. Maintain sufficient ventilation periodically to ensure sensor performance, as some operate with auto-calibration algorithms.

5. The CO₂ calibration cycle is 48 hours by default. If you wish to change it, access the “calibration” section of the [inBiot Setup App](#).

6. MICA devices ventilate both through the sides and through the air intake located at the back, so it is essential not to cover them to ensure correct sensor measurements.

7. MICA devices should not be installed in air ducts or in areas exposed to drafts with high air flow rates, as this may affect its performance, accuracy and lifetime.

9. MICA devices should not be installed in locations exposed to direct sunlight or near heat sources, as measurements may be affected.

10. Regarding Wi-Fi connection, MICA only supports 2.4GHz networks, so make sure that the credentials entered correspond to those of this band. The MICA does not support connection to 5GHz Wi-Fi networks.

11. The MICA is designed for indoor air quality monitoring. Outdoor use is under the customer’s responsibility and any damage resulting from such use will invalidate the warranty.

13. Avoid installing MICA in indoor spaces with continuous relative humidity above 85% without condensation, as it could cause irreparable damage to the device.

12. Refrain from manipulating or using unofficial spare parts for device repair or maintenance. Any attempt to do so will result in the automatic loss of device warranty.

8. For any further questions, please contact us using the form available on the inBiot [support page](#).

