



Kraków
SUDOKU
& PUZZLE
WORLD CHAMPIONSHIPS
2022



PUZZLE



SFINKS
Fundacja Rozwoju
Matematyki Rekreacyjnej

INSTRUCTION BOOKLET

World Puzzle Championship 2022 Kraków, Poland

Thursday, 20th October

09:00 – 10:00	Round 1 Individual: Countdown	60 min	450 points
10:15 – 10:45	Round 2 Individual: Araf Variations	30 min	300 points
11:00 – 12:30	Round 3 Individual: New Generation	90 min	900 points
14:00 – 15:00	Round 4 Individual: Ring of Pain	60 min	600 points
15:10 – 15:55	Round 5 Individual: Snake Variations	45 min	450 points
16:10 – 17:10	Round 6 Individual: Nightmare in Cracow	60 min	600 points
17:30 – 18:45	Round 7 Team: Cards	75 min	3200 points

Friday, 21st October

09:00 – 09:29	Round 8 Individual: 29 Under 29	29 min	290 points
09:45 – 11:00	Round 9 Individual: E Pluribus Duo	75 min	750 points
11:15 – 12:15	Round 10 Individual: Several Unsurprising Solves	60 min	600 points
14:00 – 14:45	Round 11 Individual: (Anti)Knight	45 min	450 points
15:00 – 15:45	Round 12 Individual: No Four in a Row	45 min	450 points
16:00 – 17:15	Round 13 Individual: Boss Rush	75 min	1000 points
17:45 – 18:30	Round 14 Team: Pairs	45 min	1800 points

Saturday, 22nd October

09:00 – ??:??	Round 15 Team: Tournament	? min	? points
?:?? – ?:??	Round 16 Individual: Wild Card		
?:?? – ?:??	Round 17 Individual: Playoffs		

Competition Rules

Scoring and Bonuses

Points will be awarded only for fully and correctly solved puzzles. In general, there is no partial credit unless stated otherwise in the round's description.

Individual Rounds

A bonus of 10 (20 for 29 Under 29 round) points for each full remaining minute will be awarded to any competitor who correctly solves all puzzles in a round. A partial 60% bonus can be awarded if one puzzle is incorrectly solved, under the condition that the puzzle is solved completely or almost completely and the competitor may have believed their solution to be correct. In case of doubt, the decision will be made in favour of the competitor; the decision of the judges is final.

Team Rounds

A bonus of 50 points for each full remaining minute will be awarded to any team who correctly solves all the puzzles in a round. If there are any mistakes, then no bonus will be awarded.

Competition Hall Rules

1. All competitors have to sit at their pre-allocated desk in individual rounds. Teams have to work at their pre-allocated desk area for team rounds.
2. Prior to the start of each round, competitors must ensure they are at their desks ready for the start of the round. Late arrivals may not be permitted to enter the competition hall to take part in a round (at the discretion of the organizers).
3. Prior to the start of each round, competitors have to clearly write their name, team and country on the front page of their competition booklet into the allocated space. If this information is not complete, then the organizers reserve the right not to award any points to that competitor for that round. Competitors must not open their booklets before the official start of the round.
4. When the signal for the start of the round has been given, competitors may open their booklets and begin solving the puzzles.
5. During each individual round, competitors have to keep silent, unless declaring completion of a round.
6. During team rounds, team members may talk to each other, but should do this with respect to other teams.
7. To declare a round complete, a competitor must close their booklet, clearly state "finished" and raise their arm with the booklet. The competitor's arm must be raised until the booklet is collected. The same rules apply for the team competition.
8. Competitors or teams who complete a round with more than five minutes in advance, are allowed to leave the competition hall quietly.
9. Competitors or teams who complete a round with five minutes or less left are not allowed to leave their desks or tables in order to cause no unnecessary disruption to fellow competitors.

Competition Rules

10. When a competitor leaves the competition hall for any reason, they may not be allowed to continue in that round (at the discretion of the organizers).
11. When the signal is given that the round is finished, competitors have to stop solving immediately, close their booklets, put their pens or pencils down and their hands up with their booklets for collecting.
12. At the end of a round, competitors have to remain seated until all booklets have been collected. The signal to get up and leave will be given by the supervisor.
13. Mobile phones and electronic devices are not permitted to use in the competition hall. The devices have to be turned off and must not be placed on the competitor's desk.
14. Only team captains and official observers equipped with a name tag are allowed to enter the competition hall while either individual or team rounds are taking place. Other non-competing participants may enter the competition hall at the discretion of the organizers.
15. Competitors may not use cameras or other recording devices during rounds. Only official observers may do so, at the discretion of the organizers. They have to respect the competitors and not use flash photography or cameras with excessive sounds.
16. When a competitor believes that there is a problem with a puzzle, they must clearly state that puzzle is wrong by writing "Wrong puzzle" next to it. The competitor must not notify the organizers during the round. This will be investigated upon completion of the round.
17. Puzzles can be completed in any order within a round. The points' value of a puzzle is an indication of its expected difficulty, although individual solving experience may differ. The difficulty of an example puzzle does not necessarily reflect the difficulty of the corresponding competition puzzle.

Permitted items

18. Permitted items which can be used in the competition hall (unless stated otherwise) are: pens, pencils, pencil sharpeners, erasers, rulers, blank papers and instruction booklets annotated with notes regarding puzzle instructions and preparation notes.
19. Drinks and snacks are permitted as long as they do not disturb other competitors with a strong smell or rustling packet.
20. It is strictly forbidden to use electronic devices such as music players and headphones or any type of calculator. Use of such equipment may lead to the disqualification of the competitor.
21. Any other items brought into the hall must be kept in a bag on the floor and placed under the competitor's desk, so as not to block the aisles.

Competition Rules

Marking and Queries

22. When a round has been evaluated, fully marked booklets are returned to a team member equipped with a country tag at a given location in a given time. Country tags will be distributed to each captain prior the start of the championships.

23. In case of any query after a booklet has been evaluated and returned to a competitor, the query must be raised through a team member with country tag to the organizers in the specified time. The schedule for the queries will be published before the competition. The booklet should be left with the organizers for investigation.

24. Puzzles may be photographed during the marking phase in order to prevent subsequent interventions.

25. Team captains are responsible for ensuring that any information given to them related to the competition is effectively relayed to their team.

Breach of Rules

26. Any breach of these rules may lead to penalty points, or in severe cases to a competitor or team being disqualified from the round or competition.

27. The decision of the WPC tournament director (Psyho aka Przemysław Dębiak) is final.

Final Remarks

28. In case of a major mistake in one of the rounds, organizers reserve the right to cancel the round, either by removing it from the time schedule, or by not awarding any points for it to any of the competitors.

29. The official puzzle booklets will contain one or multiple puzzles per page in the individual rounds. The rules of the puzzle and the corresponding points are always written next to it.

30. The official puzzle booklets will not contain puzzle examples. Therefore, we recommend to bring the Instruction Booklet, which contains an example of every puzzle which will be part of the championship.

31. In the team rounds, the official puzzle booklets may contain neither puzzle rules nor examples. It is advised to bring at least one Instruction Booklet for a team for these rounds.

32. In any case of inconsistency between this Instruction Booklet and the official puzzle booklets, e.g. rules or points, the information in the Instruction Booklet will be considered valid.

33. In the competition hall, a timer counting down to the end of the round will be visible for all the competitors.

Credits

34. We would like to thank the organizers of the previous WSC & WPC, we use parts of the Competition Rules from the Instruction Booklets published in the past. We would also like to thank Eric Fox, as many of instructions are copied from Eric's Puzzle Rules document.

Competition Rules

35. We would like to thank the organizers of the WPF's Grand Prix and gmpuzzles.com for allowing us to use their puzzles as examples. Every example used in the Instruction Booklet contains its author and/or source.

36. Puzzles for the WPC were created by the following designers (in the alphabetical order):

- Arvi Teikari, @ESAdevlog, <https://www.hempuli.com/blogblog/>
- Eric Fox, <https://ericfox53.blogspot.com/>
- Freddie Hand, @Puzzle_Maestro
- JinHoo Ahn
- Martin Ender, @menderbug, <https://brokensign.com/blog/>
- Michał Stajszczak
- Psyho, @FakePsyho
- RSP, @RS_Puzzling
- Sam Cappleman-Lynes
- Serkan Yürekli, @yureklis, <https://gmpuzzles.com>
- Shye, <https://shyeheya.wixsite.com/shyesstuff>
- Tom Coward, @PolmanPoppins
- Tomasz Stańczak

37. Every round in the Instruction Booklet contains the list of authors (in the alphabetical order) that have contributed puzzles to that round. **Every puzzle in the Competition Booklet will contain its author.**

Individual competition

Individual competition consists of twelve individual regular rounds, Wild Card tournament and Individual Playoffs. The individual ranking after regular rounds is determined by the sum of the scores of all regular rounds. TOP12 competitors from the individual ranking after regular rounds are qualified automatically into Playoffs. All competitors that were outside TOP12, but were the best within their own full A team (after the exclusion of TOP12) are qualified into the Wild Card tournament. Both playoffs and Wild Card tournament will inherit seeding from the individual rounds. The ties are resolved by the following tiebreaker criteria 1) score without time bonuses, 2) score in Round 12, 3) score in Round 11, ..., 11) score in Round 1, 12) random draw.

Wild Card tournament

The Wild Card tournament will consist of five rounds, where each round consists of solving a single puzzle with a maximum time of 10 minutes, where competitors are paired and duels within each pair take place. The competitors will be given seeds from 1 to 32 according to already explained rules (that is, 1st seed is the highest one). In case where less than 32 competitors are qualified into the Wild Card tournament, competitors with the highest seeds will get a bye. In the first round players will be matched in duel pairs 1-32, 2-31, ..., 16-17 according to their seeds. The winner in each pair takes the seed of the higher seeded competitor in this duel (hence competitors heading into the next round will have seeds from 1 to 16). In the second round competitors will be matched in pairs 1-16, 2-15, ..., 8-9. We continue with this scheme until the winner of the Wild Card is determined.

Duel rules

The completion of a puzzle has to be notified by flipping the paper and saying "finished". In the case where the competitor who notified the completion first solved the puzzle correctly, they are declared as the winner of the duel. Otherwise, second competitor is declared as the winner of the duel. In case that no competitor solves the puzzle correctly, competitor with better individual ranking becomes the winner.

Individual Playoff rules

TBD

Individual competition

Solving, Submission, Grading and Ranking

When a play-off competitor completes a puzzle, they must raise their hand to indicate to a judge to enter the submission period. The entire puzzle will then be checked over the next minute. After one minute, if the puzzle is correct, the judge will allow the competitor to begin the next puzzle. If the puzzle is incorrect, the judge will return the incorrect puzzle to the competitor. The competitor can resubmit a returned puzzle at any time, and will again enter the submission period. The first, second and third round of the play-off stops either with the end of the time limit, or when the first competitor solves correctly all puzzles in the round, whichever is earlier. The fourth round of the play-off stops either with the end of the time limit, or when 3 competitors correctly solve all puzzles in the round, whichever is earlier. The rank for a playoff round is determined by a) number of correctly solved puzzles, b) time of the last correct submission, c) seeding. In playoff rounds 1, 2 and 3 we care only about the winner, other players are ranked according to the score in preliminary rounds. In the big finals all positions 1-4 are determined by playoff results.

In an unlikely event of a wrong puzzle being included in one of the playoff rounds, time for each competitor is paused at the moment they solves correctly a puzzle they was solving during the wrong puzzle discovery or when the time limit ends, whichever is earlier. The competitor who chose the wrong puzzle will choose the new one that will replace it from the set of puzzles that were not chosen already. All competitors will continue with time offsets adjusted accordingly.

Team Competition

There will be three team rounds. Score for each team will be calculated as the sum of scores of its members in individual standard rounds and team scores in team rounds. There will be no team playoffs. In case of any ties the tiebreaking criteria are: 1) sum of scores from team rounds, 2) score without time bonuses, 3) score of the highest scoring team member, 4) score of the second highest scoring team member, 5) score of the third highest scoring team member, 6) random draw.

Round by

Eric Fox
JinHoo Ahn
Martin Ender
Psyho
Serkan Yürekli

Puzzles

1.1 Pentominous	45 Points
1.2 Country Road	45 Points
1.3 Nanro	45 Points
1.4 Double Choco	30 Points
1.5 Cave	45 Points
1.6 Yajilin (Regions)	40 Points
1.7 Shakashaka	40 Points
1.8 Tapa	25 Points
1.9 Slitherlink	50 Points
1.10 Ripple Effect	85 Points

1.1 Pentominous

Example to Sam Cappleman-Lynes

Divide the grid into regions of five orthogonally connected cells so that no two regions of the same shape share an edge, counting rotations and reflections as the same. Clued cells must belong to a region with the pentomino shape associated with that letter.

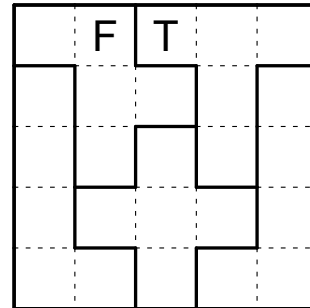
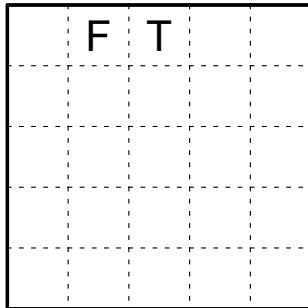

1.2 Country Road

Example by Serkan Yürekli / gmpuzzles.com

Draw a single, non-intersecting loop in the grid that enters and exits each bold region exactly once. If a number clue is given in a region, that number indicates the exact number of cells used by the loop in the region. Unused cells cannot be orthogonally adjacent across different regions.

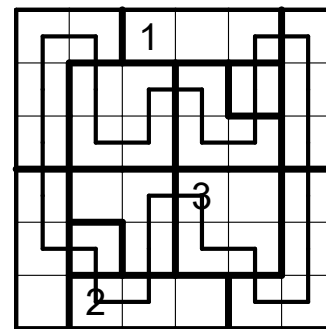
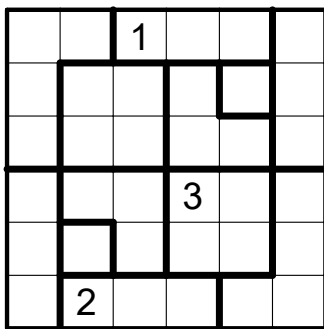

1.3 Nanro

Example from gmpuzzles.com

Label some cells with numbers to form a single connected group of labeled cells; no 2x2 group of cells may be fully labeled. Each bold region must contain at least one labeled cell. Each number (including any given numbers) must equal the total count of labeled cells in that region. When two numbers are orthogonally adjacent across a region boundary, the numbers must be different.

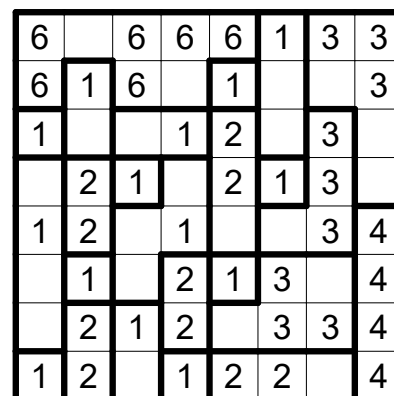
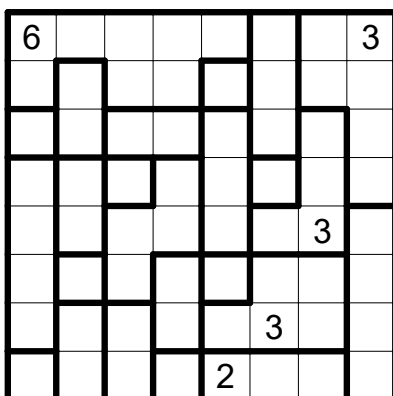

1.4 Double Choco

Example from GP 2022 R6

Divide the grid into regions of orthogonally connected cells, each containing a connected group of white cells and a connected group of grey cells, with the property that the shape of the white cells is identical to the shape of the grey cells, allowing rotations and reflections. Clued cells must belong to a region containing the indicated number of white cells and the indicated number of grey cells.

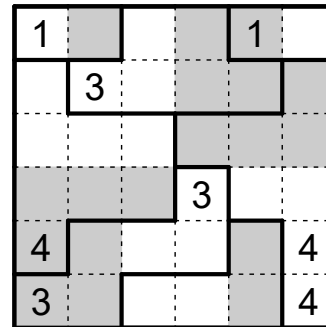
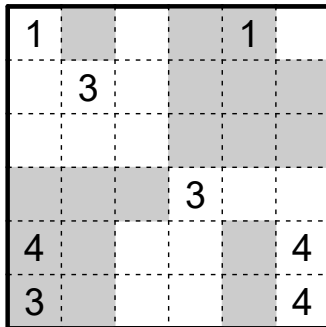

1.5 Cave

Example from GP 2018 R8

Shade some cells so that the shaded cells are all connected orthogonally by other shaded cells to the edge of the grid, and the remaining unshaded cells form one orthogonally connected area. Clues cannot be shaded, and represent the total number of unshaded cells that can be seen in a straight line vertically or horizontally, including itself.

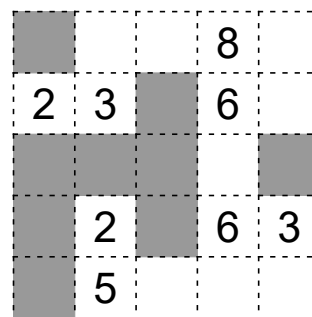
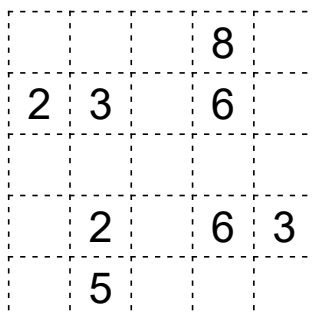

1.6 Yajilin (Regions)

Example by Sam Cappleman-Lynes

Shade some cells so that no two shaded cells are orthogonally adjacent and draw a non-intersecting loop through the centers of all the remaining cells. Numbered regions must contain the indicated amount of shaded cells.

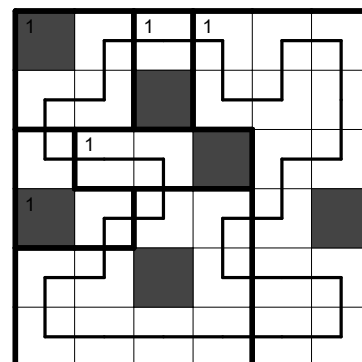
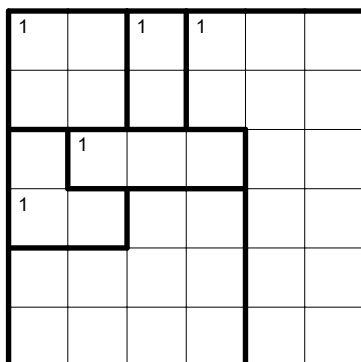

1.7 Shakashaka

Example by Sam Cappleman-Lynes

Shade a right triangle in some empty cells, each of which occupies exactly half the cell it's in. Each unshaded area must be rectangular in shape. A number in a cell represents how many of the (up to) four cells orthogonally adjacent to the clue contain triangles.

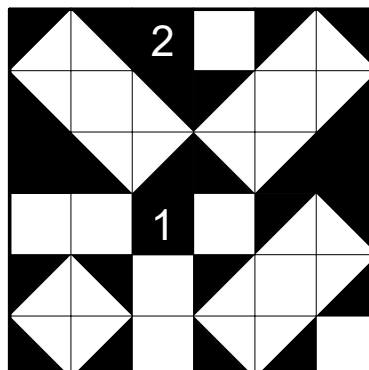
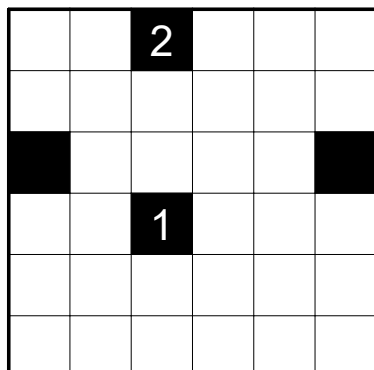

1.8 Tapa

Example from GP 2022 R2

Shade some cells so that all shaded cells form one orthogonally connected area. Clues cannot be shaded, and represent the lengths of the blocks of consecutive shaded cells in the (up to) eight cells surrounding the clue. No 2x2 region may be entirely shaded.

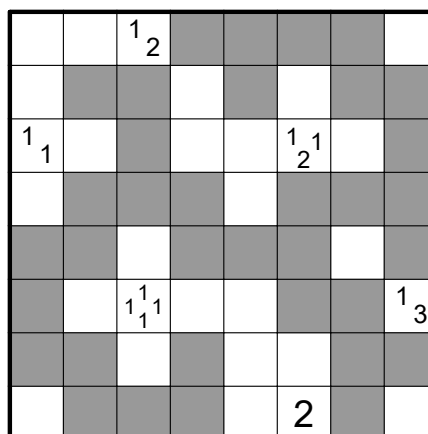
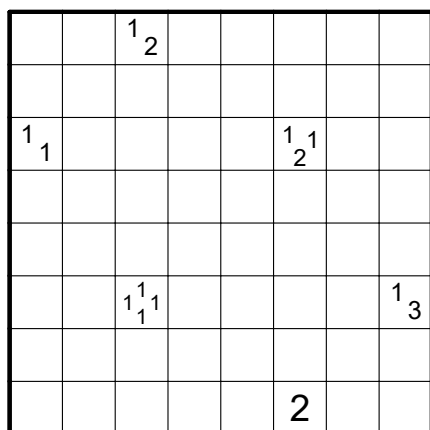

1.9 Slitherlink

Example from GP 2022 R7

Draw a single non-intersecting loop along the dotted segments. Clues represent the number of edges drawn surrounding the clue.

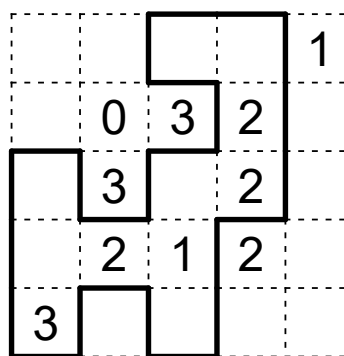
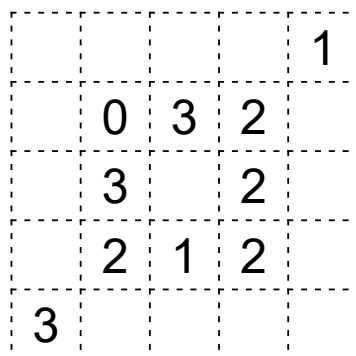

1.10 Ripple Effect

Example by JinHoo Ahn

Place a number into each cell so that each region contains the numbers from 1 to N with no repeats, where N is the number of cells in the region. If two identical numbers appear in the same row or column, then at least that many cells with other numbers (or an equivalent distance) must separate them.

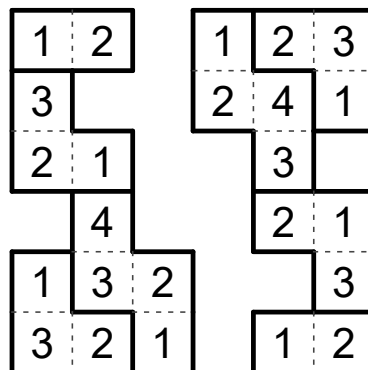
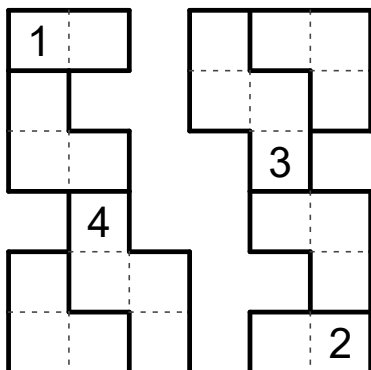

Round by

Serkan Yürekli

Puzzles

2.1-3 Araf	20 + 25 + 30 Points
2.4 Araf (Line)	60 Points
2.5 Araf (Different Neighbors)	50 Points
2.6 Araf (Skyscrapers)	75 Points
2.7 Araf (Singleton)	40 Points

2.1-3 Araf

Example by Serkan Yürekli

Divide the grid into regions of orthogonally connected cells. Each region must contain exactly two circles and have an area that lies between the two numbers in the circles, exclusive.

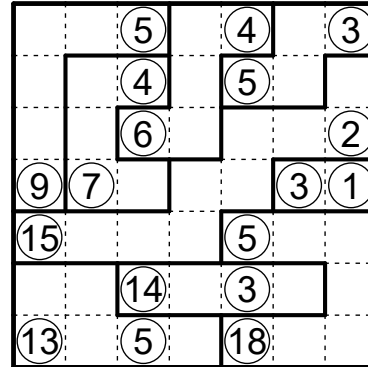
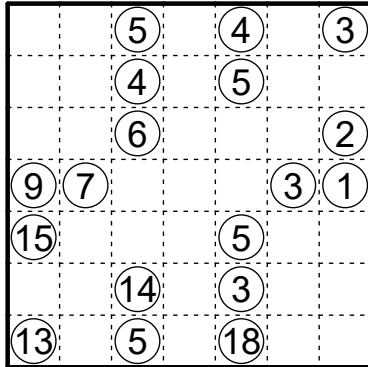

2.4 Araf (Line)

Example by Serkan Yürekli

Divide the grid into regions of orthogonally connected cells. Each region must contain exactly two circles and have an area that lies between the two numbers in the circles, exclusive. No region may contain a line of more than three consecutive cells horizontally or vertically.

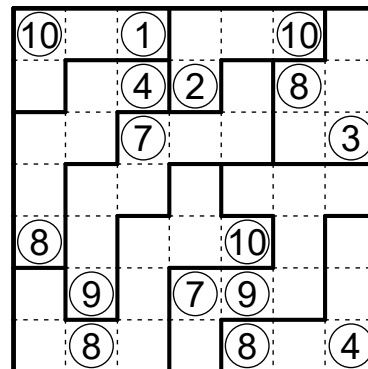
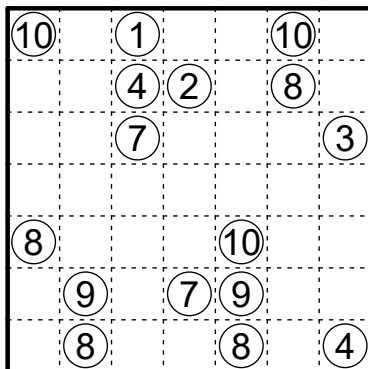

2.5 Araf (Different Neighbors)

Example by Serkan Yürekli

Divide the grid into regions of orthogonally connected cells. Each region must contain exactly two circles and have an area that lies between the two numbers in the circles, exclusive. Two regions of the same size may not share an edge.

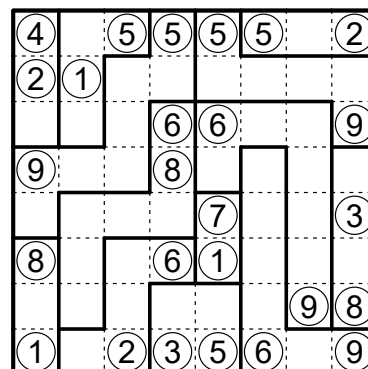
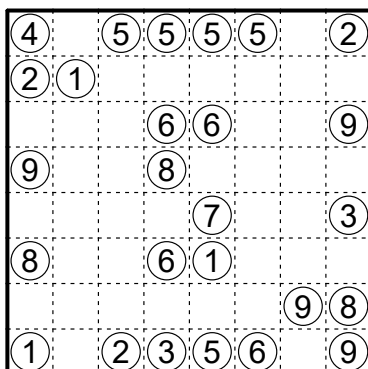

2.6 Araf (Skyscrapers)

Example by Serkan Yürekli

Divide the grid into regions of orthogonally connected cells. Each region must contain exactly two circles and have an area that lies between the two numbers in the circles, exclusive. A clue outside the grid indicates the number of maximal groups of consecutive cells belonging to the same region within the corresponding row or column which are larger than all maximal groups before them in that row or column from the direction of the clue.

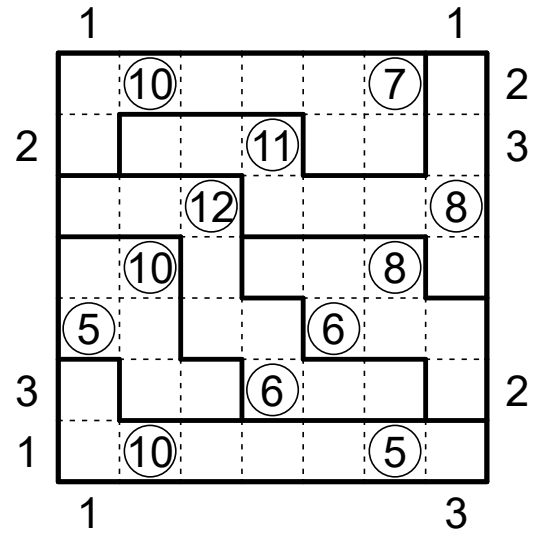
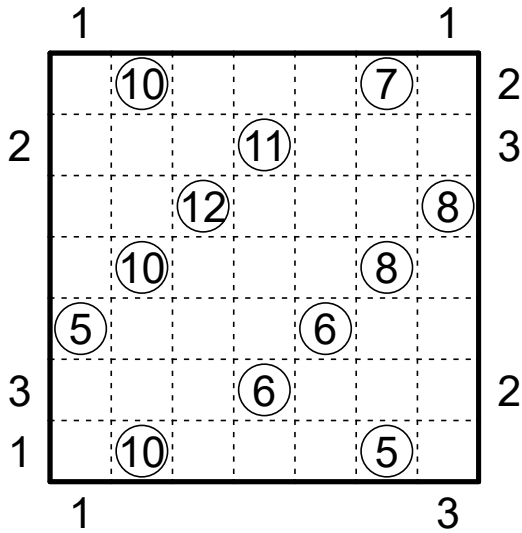

2.7 Araf (Singleton)

Example by Serkan Yürekli

Divide the grid into regions of orthogonally connected cells. Each region contains either one or two circles. If the region contains only one circle, its size must be equal to the number in the circle. In the other case, its area must lie between the two numbers in the circles, exclusive.

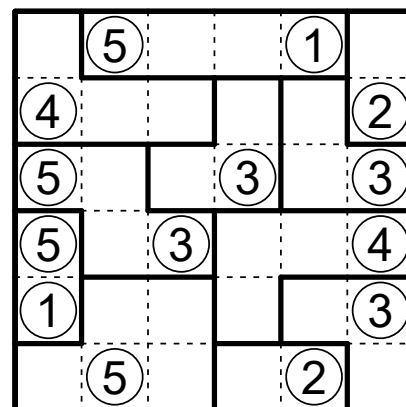
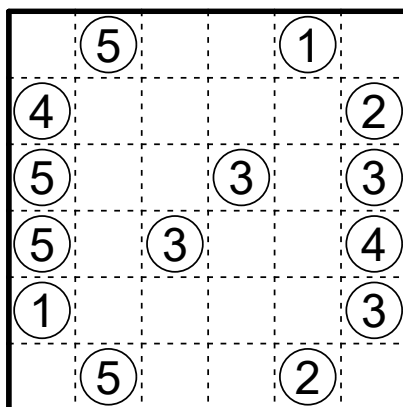

Round by

Arvi Teikari
 Eric Fox
 Martin Ender
 RSP
 Shye

Puzzles

3.1-4 Aqre15 + 25 + 30 + 35 Points
3.5-8 Square Jam	10 + 10 + 20 + 25 Points
3.9-12 Disorderly Loop15 + 15 + 20 + 30 Points
3.13-16 La Paz	20 + 30 + 35 + 40 Points
3.17-20 Rail Pool	10 + 35 + 40 + 60 Points
3.21-24 Context	15 + 30 + 35 + 45 Points
3.25-28 Celltinels20 + 20 + 25 + 50 Points
3.29-32 Limited Alike	10 + 30 + 40 + 60 Points

3.1-4 Aqre

Example by Eric Fox

Shade some cells so that all shaded cells form one orthogonally connected area. Regions with numbers must contain the indicated amount of shaded cells. There may not exist a run of more than three consecutive shaded or unshaded cells horizontally or vertically anywhere in the grid.

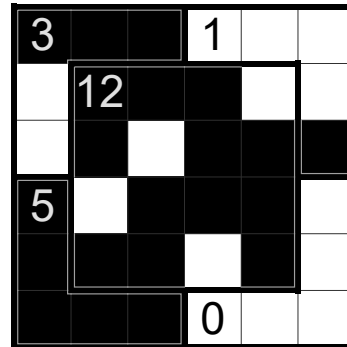
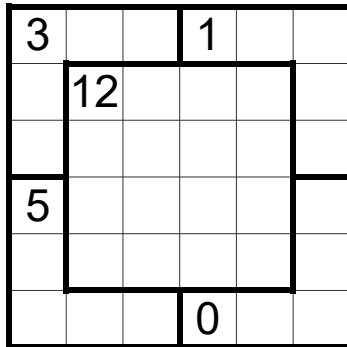

3.5-8 Square Jam

Example by Eric Fox

Divide the grid into square regions of orthogonally connected cells. A number indicates the side length of the square it's in. Region borders may not form any four-way intersections.

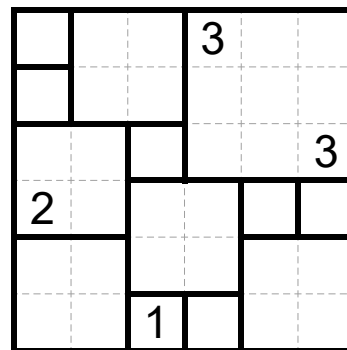
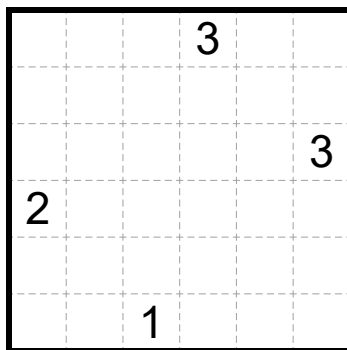

3.9-12 Disorderly Loop

Example by Eric Fox

Draw a non-intersecting loop through the centers of some cells. Clued cells may not be used by the loop. Clues represent the lengths of the next N line segments appearing in the loop, not necessarily in order, starting with a line in the cell adjacent to the clue in the direction of its arrow and moving in the direction of the arrow, where N is the amount of numbers in the clue.

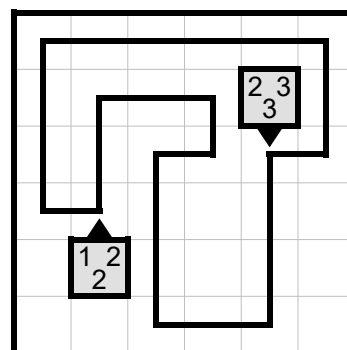
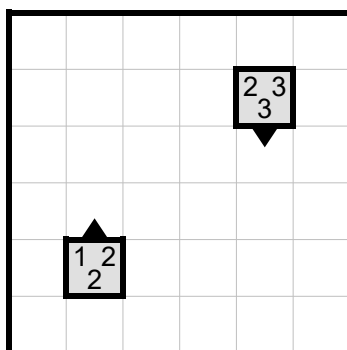

3.13-16 La Paz

Example by Shye

Shade some cells so that no two shaded cells are orthogonally adjacent and divide the remaining unshaded cells into two-cell regions. Clued cells cannot be shaded. A clue indicates the number of shaded cells which lie entirely within the same row or column as the region containing the clue.

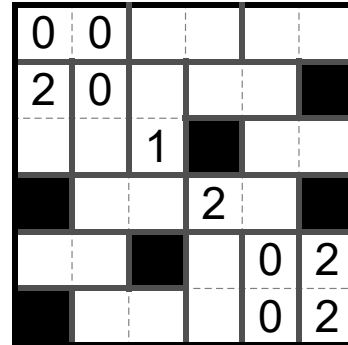
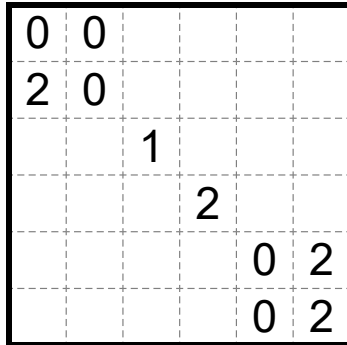

3.17-20 Rail Pool

Example by Martin Ender

Draw a non-intersecting loop through the centers of all cells. Clues represent all of the different lengths of the straight line segments that are at least partially contained within the region. Each number within a region must be represented by at least one line segment. Each ? represents a positive integer, and numbers cannot repeat within a region.

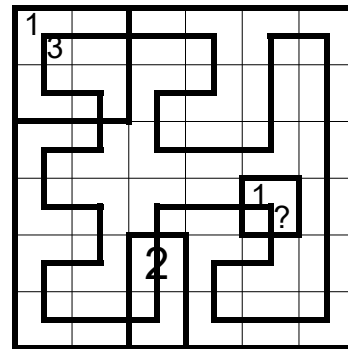
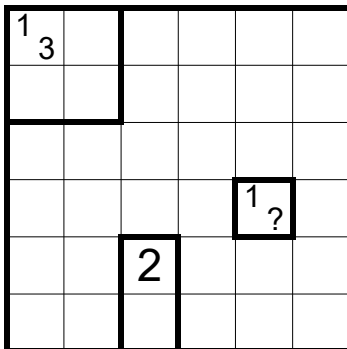

3.21-24 Context

Example by RSP

Shade some cells so that no two shaded cells are orthogonally adjacent and the remaining unshaded cells form one orthogonally connected area. An unshaded clue indicates the number of orthogonally adjacent shaded cells. A shaded clue indicates the number of diagonally adjacent shaded cells.

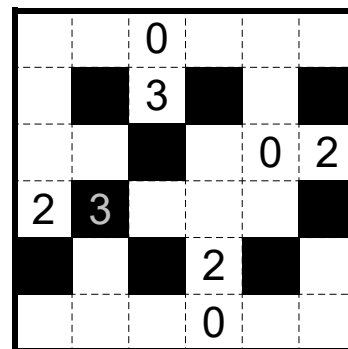
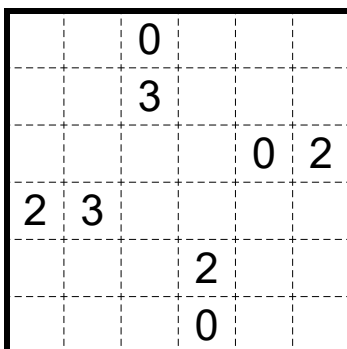

3.25-28 Celltinels

Example by Arvi Teikari

Shade some cells to form a non-intersecting loop which does not touch itself, not even diagonally. Clues cannot be shaded, and represent the total number of shaded cells that appear in a straight line vertically or horizontally from the clue. Clues cannot see through other clues. Empty gray squares represent a clue that doesn't convey any additional information.

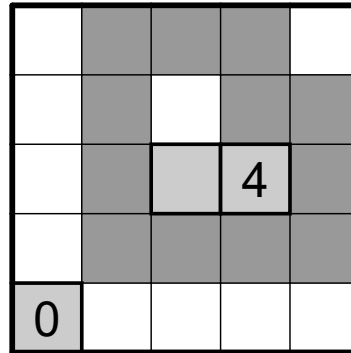
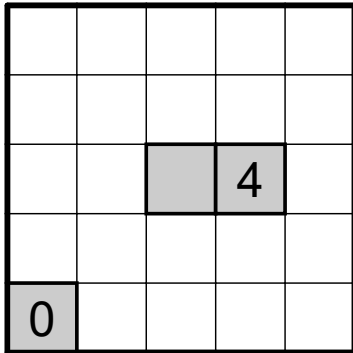

3.29-32 Limited Alike

Example by Arvi Teikari

Shade an orthogonally connected group of at least one cell within each region such that all shaded cells form one orthogonally connected area with no loops. No 2x2 area may be entirely shaded. A number indicates how many cells are shaded within its region. No two regions which share an edge may contain the same number of shaded cells. For any number X, a maximum of X regions may contain exactly X shaded cells.

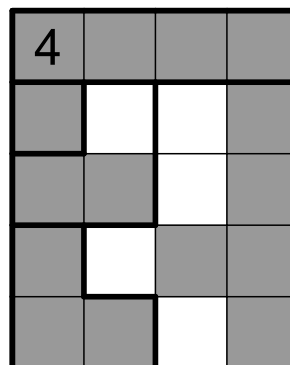
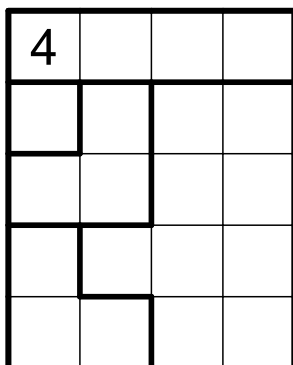

Round by

Sam Cappleman-Lynes

Puzzles

4.1 Shakashaka	60 Points
4.2 Shakabe	60 Points
4.3 Nurikabe	70 Points
4.4 Nuriminous	20 Points
4.5 Pentominous	40 Points
4.6 Pento Galaxies	50 Points
4.7 Spiral Galaxies	60 Points
4.8 Spirallin	55 Points
4.9 Yajilin	40 Points
4.10 Yaji Battle	40 Points
4.11 Star Battle	60 Points
4.12 Star Shaka	45 Points

4.1 Shakashaka

Example by Sam Cappleman-Lynes

Shade a right triangle in some empty cells, each of which occupies exactly half the cell it's in. Each unshaded area must be rectangular in shape. A number in a cell represents how many of the (up to) four cells orthogonally adjacent to the clue contain triangles.

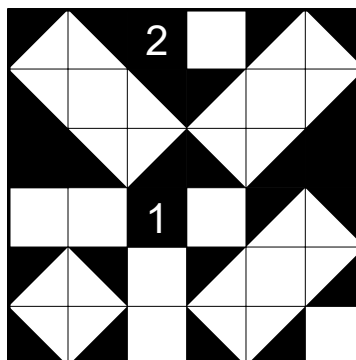
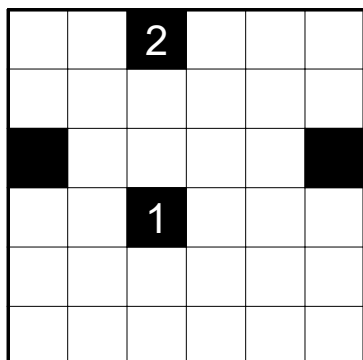

4.2 Shakabe

Example by Sam Cappleman-Lynes

In some cells, shade a right triangle occupying half of the cell, so that all unshaded areas are in the shape of rectangles. Cells containing numbers cannot be shaded and must belong to a rectangle whose area is equal to the given number.

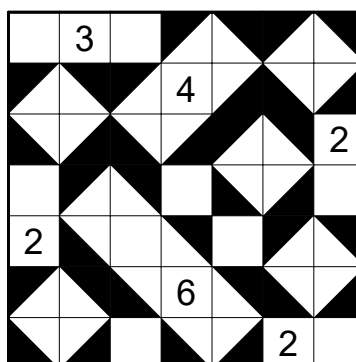
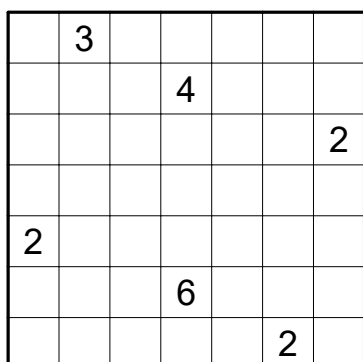

4.3 Nurikabe

Example by Sam Cappleman-Lynes

Shade some cells so that all shaded cells form one orthogonally connected area. Clues cannot be shaded, and every orthogonally connected area of unshaded cells contains exactly one clue, the value of which represents the size of the area. No 2x2 region may be entirely shaded.

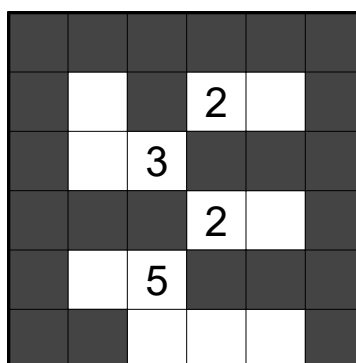
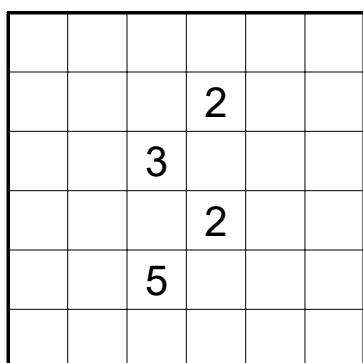

4.4 Nuriminous

Example by Sam Cappleman-Lynes

Shade some cells so that all shaded cells are connected and no 2x2 area is entirely shaded. Each unshaded area must contain exactly one letter, be five cells in size, and have the shape of the pentomino corresponding to its letter.

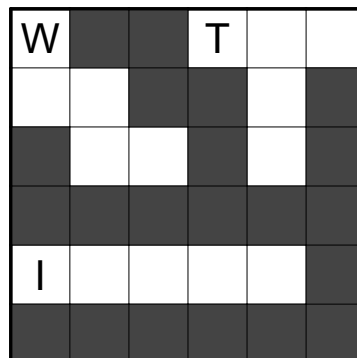
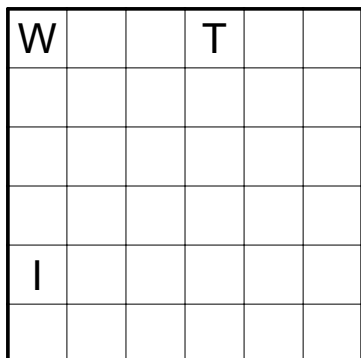

4.5 Pentominous

Example by Sam Cappleman-Lynes

Divide the grid into regions of five orthogonally connected cells so that no two regions of the same shape share an edge, counting rotations and reflections as the same. Clued cells must belong to a region with the pentomino shape associated with that letter.

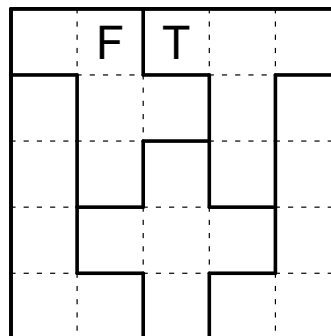
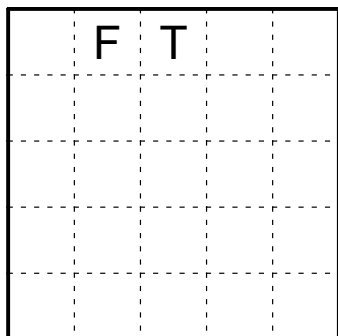

4.6 Pento Galaxies

Example by Sam Cappleman-Lynes

Divide the grid into regions of five orthogonally connected cells so that no two regions of the same shape share an edge, counting rotations and reflections as the same. The center of every rotationally symmetric region is marked with a dot.

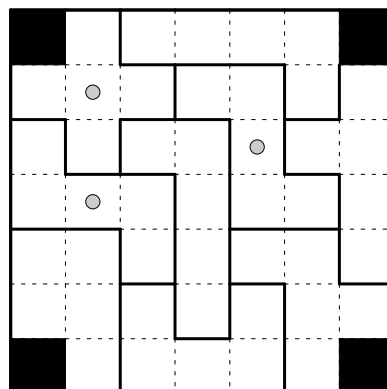
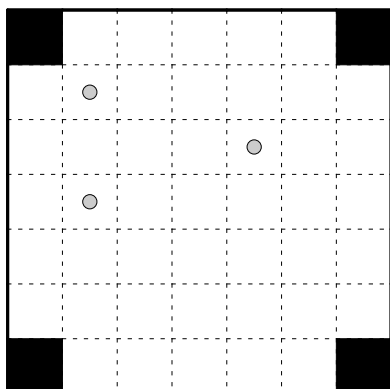

4.7 Spiral Galaxies

Example by Sam Cappleman-Lynes

Divide the grid into regions of orthogonally connected cells. Each region must contain exactly one circle and have 180° rotational symmetry around it.

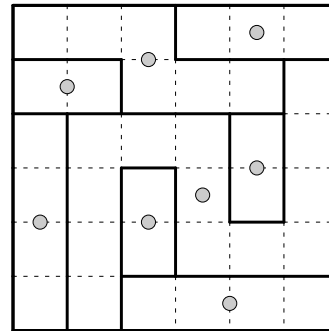
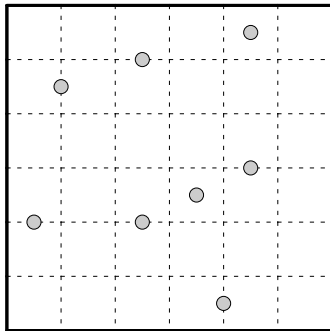

4.8 Spirallin

Example by Sam Cappleman-Lynes

Divide the grid along the gridlines into areas which are rotationally symmetric. The centre of every area is marked with a circle. A number with an arrow in such a circle indicates how many cells in a straight line in the indicated direction, belong to the area centered on that circle.

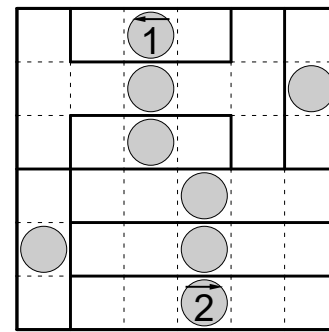
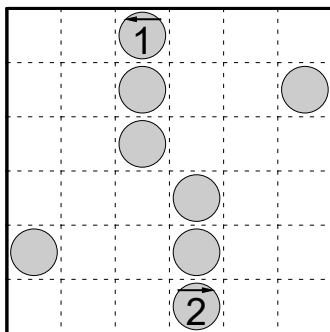

4.9 Yajilin

Example by Sam Cappleman-Lynes

Shade some cells so that no two shaded cells are orthogonally adjacent and draw a non-intersecting loop through the centers of all the remaining empty cells. Clues cannot be shaded, and represent the number of shaded cells in a straight line in the indicated direction.

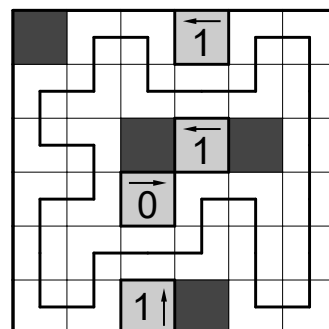
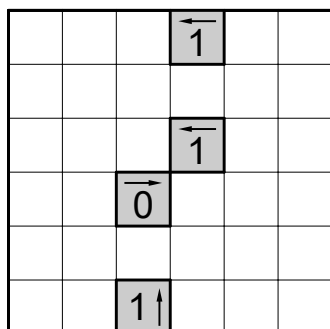

4.10 Yaji Battle

Example by Sam Cappleman-Lynes

Shade some empty cells so that no two shaded cells are adjacent and draw a single loop through all remaining empty cells. Every outlined area must contain exactly 2 (1 in the example) shaded cells.

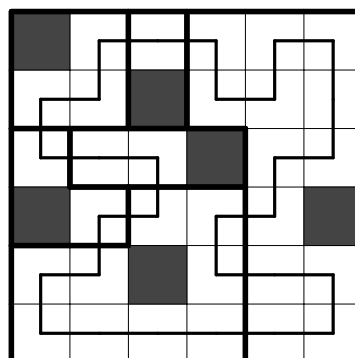
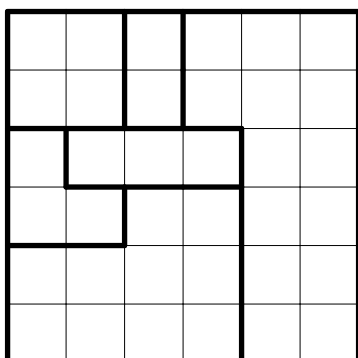

4.11 Star Battle

Example by Sam Cappleman-Lynes

Place stars into some cells such that each row, column, and outlined region contains exactly 2 (1 in the example) stars. Stars may not touch one another, not even diagonally.

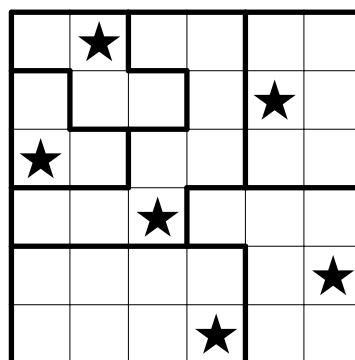
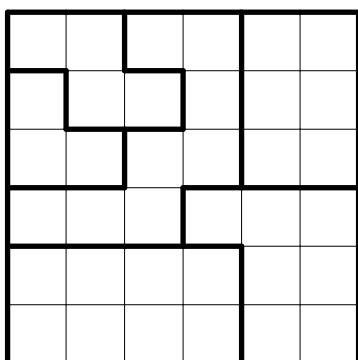

4.12 Star Shaka

Example by Sam Cappleman-Lynes

Place a star into some empty cells so that every row and column contains exactly 2 (1 in the example) stars. Stars must not be placed in cells which touch along an edge or at a corner. A numbered clue indicates how many stars are placed in the (up to) four cells sharing an edge with that clue.

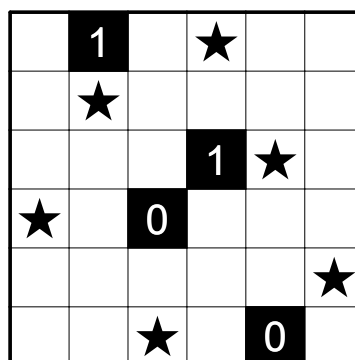
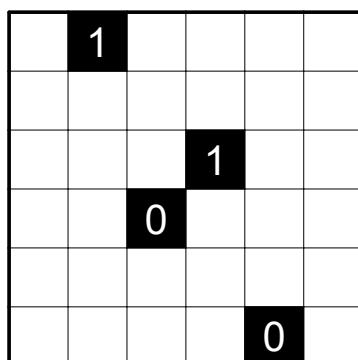

Round by

Serkan Yürekli

Puzzles

5.1 First Seen Snake	30 Points
5.2 Easy as Snake	100 Points
5.3 Spiral Snake	50 Points
5.4 Prime Snake	80 Points
5.5 The Persistence of Memory	85 Points
5.6 Snake Egg	40 Points
5.7 Sea Serpent	65 Points

5.1 First Seen Snake

Example by Serkan Yürekli

Draw a 45 long (23 in the example) snake (a 1 cell-wide path) in the grid whose head and tail are given by circled cells. The snake cannot touch itself, not even diagonally. Exterior clues indicate the length of the first snake segment seen from the corresponding direction.

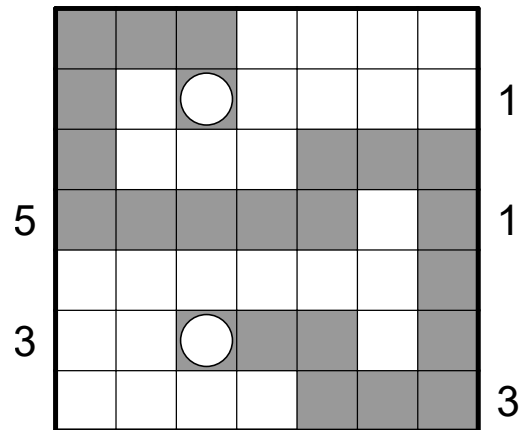
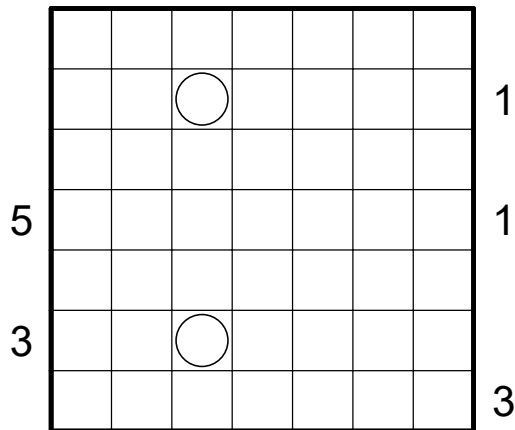

5.2 Easy as Snake

Example by Serkan Yürekli

Draw a snake (a 1 cell-wide path) in the grid whose head and tail are given by circled cells. The snake cannot touch itself, not even diagonally. Each arrow points at exactly 3 cells of the snake in the corresponding direction. Fill some of the snake cells with the letters A,B,C so that each row and column contains each letter exactly once. All letters must be on the snake. Snake cannot pass through cells with arrows. A clue outside the grid represents the first letter seen in the corresponding row or column from that direction.

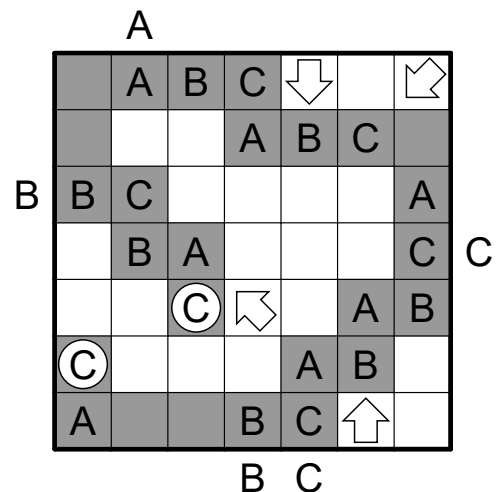
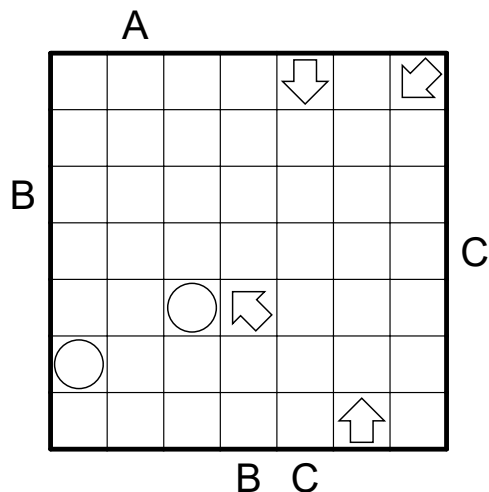

5.3 Spiral Snake

Example by Serkan Yürekli

Divide the grid along the indicated lines into connected regions with rotational symmetry. Each cell must belong to one region and each region must have exactly one circle at its center of rotational symmetry. Then draw a snake (a 1-cell wide path) of unknown length in the grid whose head and tail are given by circled cells. The snake cannot touch itself, not even diagonally. The pattern of occupied and unoccupied cells by the snake within a region must have 180 degree rotational symmetry around the region's center.

Note: In order to receive full credit for the puzzle, it's enough to just shade the snake.

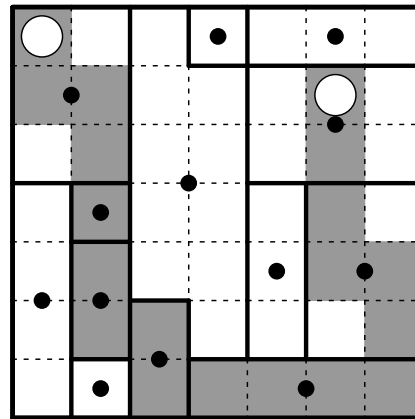
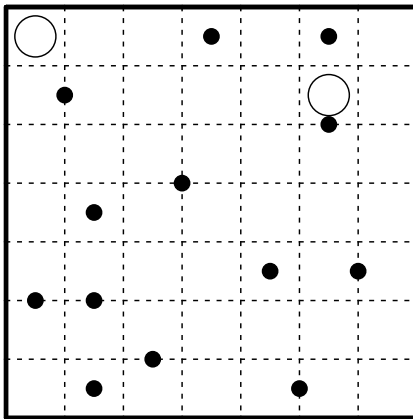

5.4 Prime Snake

Example by Serkan Yürekli

Fill in every circle inside and outside the grid with a prime number. (All prime numbers inside and outside the grid are marked.) Then locate a numbered snake (a 1-cell wide path) that starts with 1 and goes to N (N is unknown). The snake cannot touch itself, not even diagonally. All numbers inside the grid, belong to the snake. Digits outside the grid indicate how many cells in that row or column are occupied by the snake.

Note: In order to receive full credit for the puzzle, it's enough to just shade the snake (no numbers are necessary).

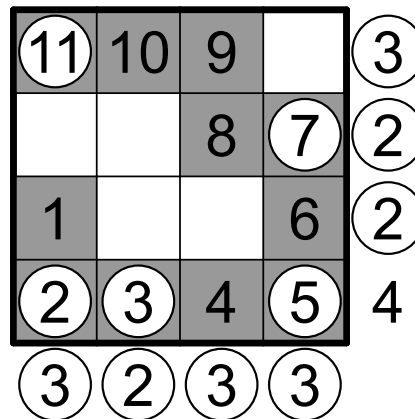
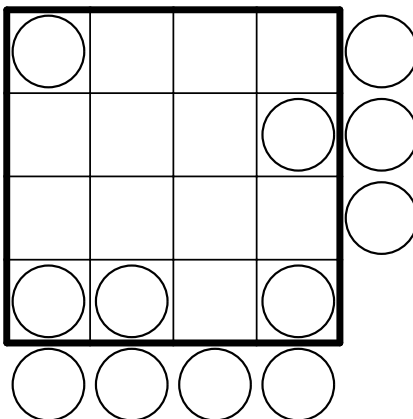

5.5 The Persistence of Memory

Example by Serkan Yürekli

Draw a snake (a 1-cell wide path) from one dot to the other by moving horizontally or vertically between adjacent squares. The snake cannot touch itself, not even diagonally. All highlighted regions must be visited by the snake, and may be re-entered. If two or more highlighted regions have the same shape and orientation, then how the path passes through those shapes must be identical.

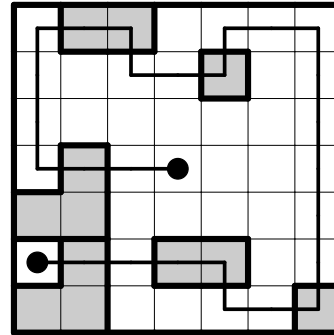
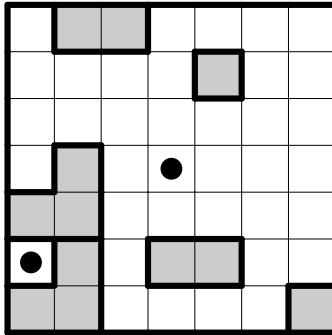

5.6 Snake Egg

Example by Serkan Yürekli

Draw a snake (a 1 cell-wide path) in the grid whose head and tail are given by circled cells. The snake can touch itself diagonally, but cannot touch itself orthogonally or revisit any square. Besides the snake, the remaining cells must form exactly nine white areas, one of each size from 1 to 9 (1 to 5 in the example). Numbers in the grid must be part of white areas of the indicated size.

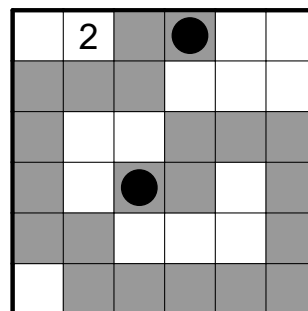
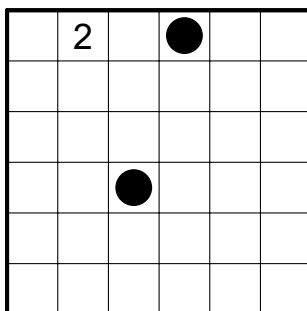

5.7 Sea Serpent

Example by Serkan Yürekli

Draw a snake (a 1 cell-wide path) in the grid whose head and tail are given by circled cells. The snake can touch itself diagonally, but cannot touch itself orthogonally and cannot pass through any blackened cells. The given numbers show the total number of cells that are used by the snake in the grid along the indicated directions. Numbers see to the border of the grid.

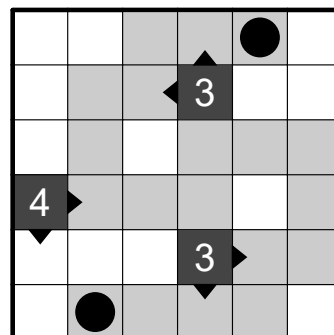
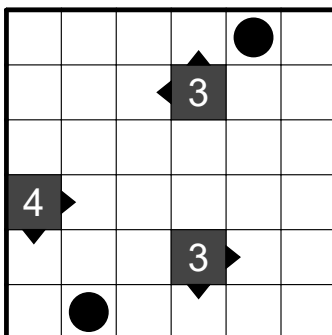

Round by

JinHoo Ahn

Puzzles

6.1 Masyu (Crossing)	40 Points
6.2 Star Battle (Toroidal)	40 Points
6.3 Pentominous (Liar)	65 Points
6.4 Tapa-like Loop (Crossing+Toroidal)	115 Points
6.5 Myopia (Crossing+Liar)	115 Points
6.6 Suguru (Liar+Toroidal)	90 Points
6.7 Slitherlink (Crossing+Toroidal+Liar)	135 Points

Round Information

In all puzzles the meaning of Crossing, Toroidal and Liar is the same.

Crossing: The loop is allowed to cross itself. The loop is not allowed to turn at the crossing.

Toroidal: The grid is toroidal, which means that the first and the last rows/columns are considered adjacent.

Liar: In every row and column there is exactly one clue that's incorrect. Incorrect clue means that the clue describes the opposite property compared to the standard rules of the puzzle, e.g. In Pentominous the incorrect clue V would mean that the pentomino that contains this clue can not be a V pentomino.

6.1 Masyu (Crossing)

Example by JinHoo Ahn

Draw a loop through the centers of some cells that passes through every circle. Two perpendicular line segments may intersect each other, but not turn at their intersection or otherwise overlap. The loop must turn on black circles and travel straight through the cells on either side. The loop must go straight through white circles, and turn in at least one of the cells on either side.

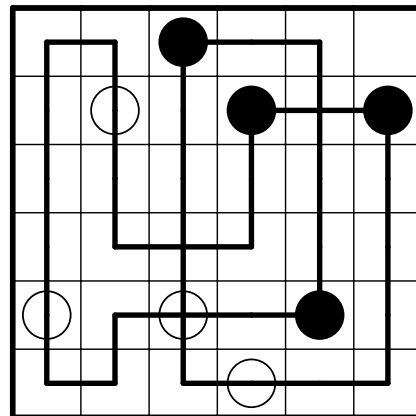
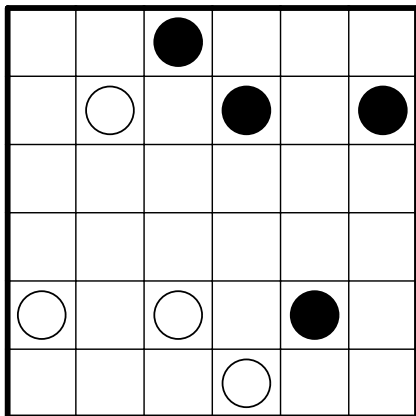

6.2 Star Battle (Toroidal)

Example by JinHoo Ahn

Place stars into some cells such that each row, column, and outlined region contains exactly N stars. The value of N is given outside the grid. Stars may not touch one another, not even diagonally. The grid is toroidal, which means that the first and the last rows/columns are considered adjacent.

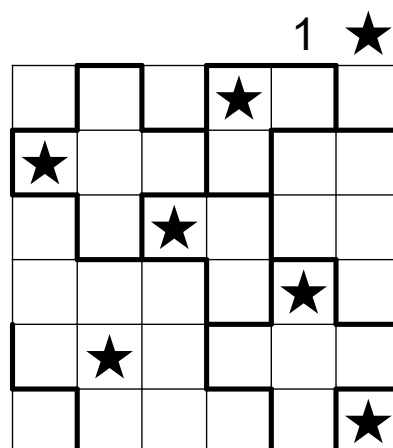
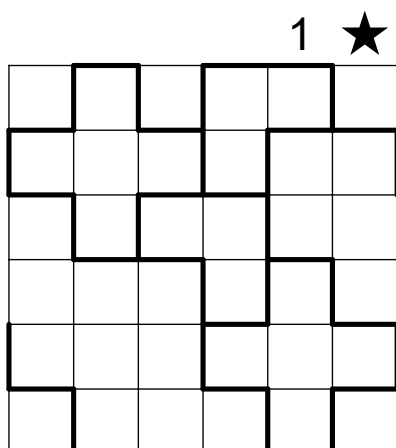

6.3 Pentominous (Liar)

Example by JinHoo Ahn

Divide the grid into regions of five orthogonally connected cells so that no two regions of the same shape share an edge, counting rotations and reflections as the same. Clued cells must belong to a region with the pentomino shape associated with that letter. In every row and column there is exactly one clue that's incorrect.

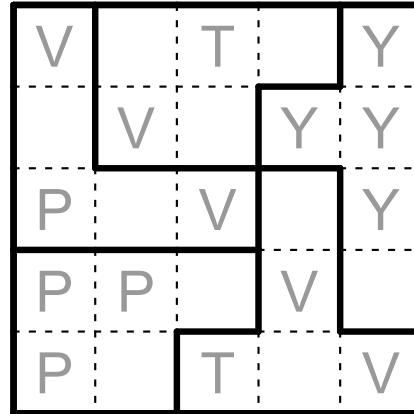
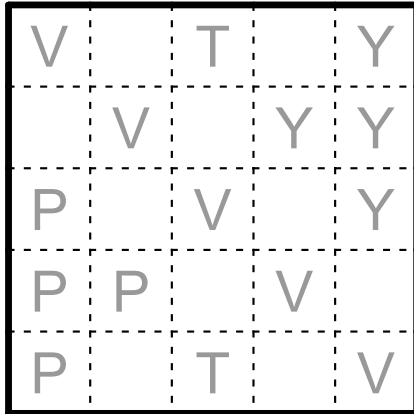

6.4 Tapa-like Loop (Crossing+Toroidal)

Example by JinHoo Ahn

Draw a loop through the centers of some empty cells. Two perpendicular line segments may intersect each other, but not turn at their intersection or otherwise overlap. Clues represent the numbers of consecutive cells occupied by the loop each time it enters the (up to) eight cells surrounding the clue. The grid is toroidal, which means that the first and the last rows/columns are considered adjacent.

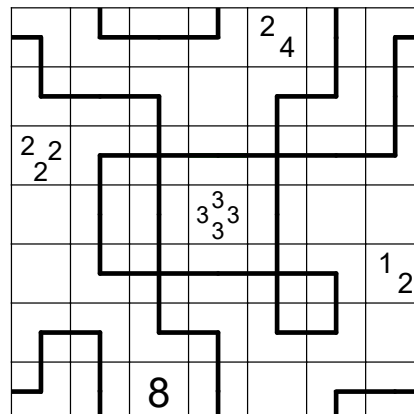
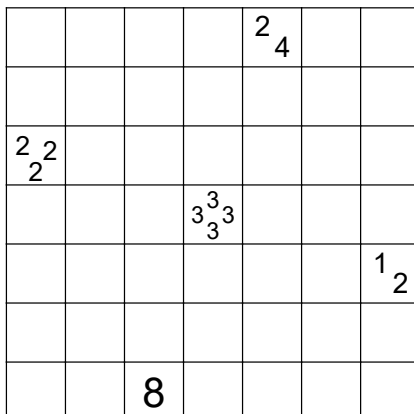

6.5 Myopia (Crossing+Liar)

Example by JinHoo Ahn

Connect some pairs of orthogonally adjacent dots to form a single loop. Two perpendicular line segments may intersect each other, but not turn at their intersection or otherwise overlap. Clued cells contain arrows indicating all of the orthogonal directions in which a loop segment appears closest to the clued cell. In every row and column there is exactly one clue that's incorrect.

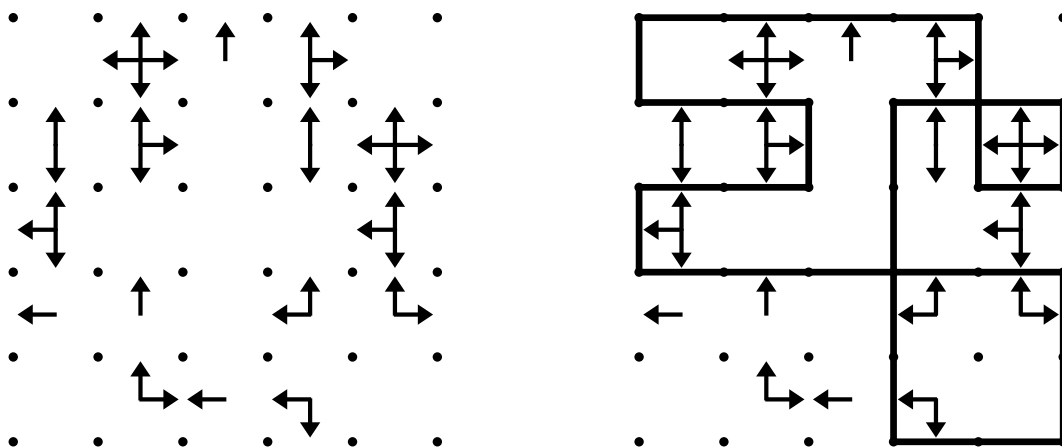

6.6 Suguru (Toroidal+Liar)

Example by JinHoo Ahn

Place a number into each cell so that each region contains the numbers from 1 to N with no repeats, where N is the number of cells in the region. Numbers of the same value may not touch one another, not even diagonally. In every row and column there is exactly one clue that's incorrect. The grid is toroidal, which means that the first and the last rows/columns are considered adjacent.

	4	1	3	5	
5		6	2		3
2	2			4	2
3	6			3	1
4		3	1		5
	2	4	6	4	

4	6	1	3	5	2
5	3	4	2	1	3
4	2	1	6	4	2
3	6	5	2	5	1
4	1	3	1	3	6
3	2	4	2	4	1

6.7 Slitherlink (Crossing+Toroidal+Liar)

Example by JinHoo Ahn

Connect some pairs of orthogonally adjacent dots to form a single loop. Two perpendicular line segments may intersect each other, but not turn at their intersection or otherwise overlap. Clues represent the number of edges drawn surrounding the clue. In every row and column there is exactly one clue that's incorrect. The grid is toroidal, which means that first and last row/column are considered adjacent. This means that the top and the bottom edges are exactly the same. Same for the leftmost and the rightmost edges.

Note: If your exterior edge doesn't match the other side (i.e. it's present on one side, but not on the corresponding side), we will assume that you intended to draw them on both sides. This is in order to avoid penalizing silly mistakes.

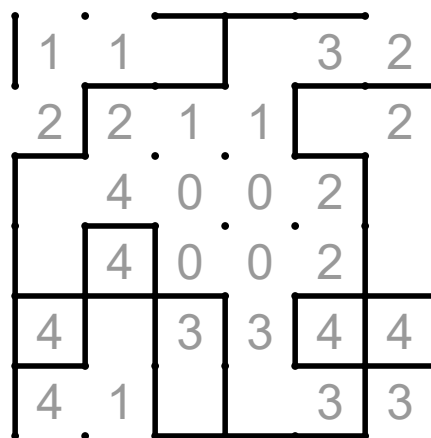
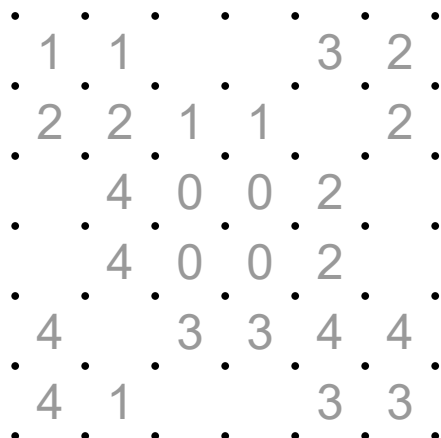

Round by

Eric Fox
Freddie Hand
JinHoo Ahn
Martin Ender
Psyho
Sam Cappleman-Lynes
Serkan Yürekli
Shye

Puzzles

10 points per puzzle

- | | |
|-----------------------|------------------------|
| 8.1 Japanese Arrows | 8.16 Cave |
| 8.2 Nurikabe | 8.17 Fillomino |
| 8.3 Heyawake | 8.18 Rail Pool |
| 8.4 Spiral Galaxies | 8.19 Aqre |
| 8.5 Araf | 8.20 Mochikoro |
| 8.6 Slash Pack | 8.21 Norinori |
| 8.7 Pentominous | 8.22 Geradeweg |
| 8.8 Snake Egg | 8.23 Slitherlink |
| 8.9 Tents | 8.24 Japanese Sums |
| 8.10 Anglers | 8.25 Double Choco |
| 8.11 Castle Wall | 8.26 Yajilin (Regions) |
| 8.12 Irregular Sudoku | 8.27 Balance Loop |
| 8.13 Skyscrapers | 8.28 Statue Park |
| 8.14 X-Sums | 8.29 Kurotto |
| 8.15 Doppelblock | |

Round Information

All of the grids in this round are small (up to 6x6).
 The puzzles in this round are (roughly) sorted by expected difficulty.
The time bonus for this round is doubled: 20 points for each full saved minute.

8.1 Japanese Arrows

Example by Martin Ender

Place a number into each cell such that each number indicates how many different numbers are in a straight line in the direction of its arrow, not including itself.

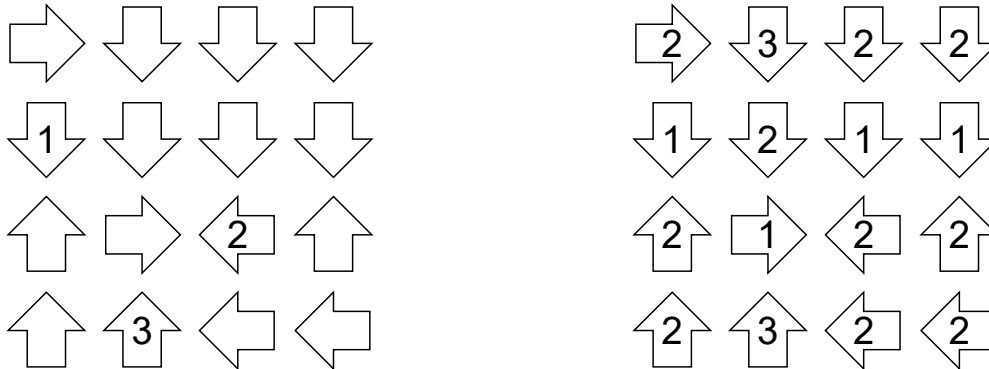

8.2 Nurikabe

Shade some cells so that all shaded cells form one orthogonally connected area. Clues cannot be shaded, and every orthogonally connected area of unshaded cells contains exactly one clue, the value of which represents the size of the area. No 2x2 region may be entirely shaded.

[Check Example → 4.3](#)

8.3 Heyawake

Example by Serkan Yürekli / gmpuzzles.com

Shade some cells so that no two shaded cells are orthogonally adjacent and the remaining unshaded cells form one orthogonally connected area. Numbered regions must contain the indicated amount of shaded cells. A line of consecutive unshaded cells may not cross more than one bold border.

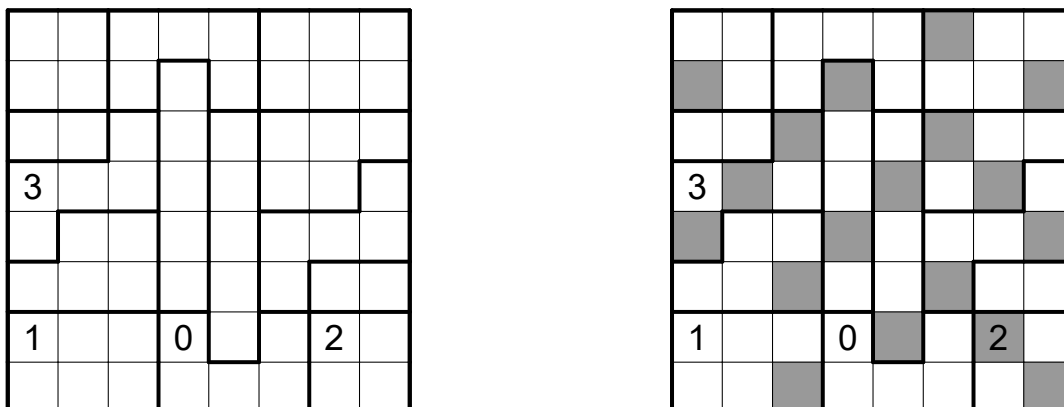

8.4 Spiral Galaxies

Example from GP 2022 R3

Divide the grid into regions of orthogonally connected cells. Each region must contain exactly one circle and have 180° rotational symmetry around it.

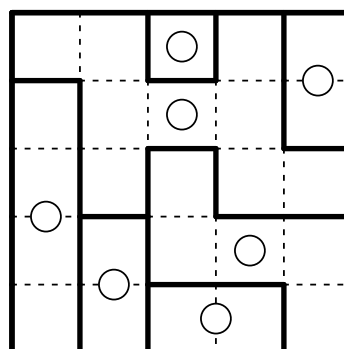
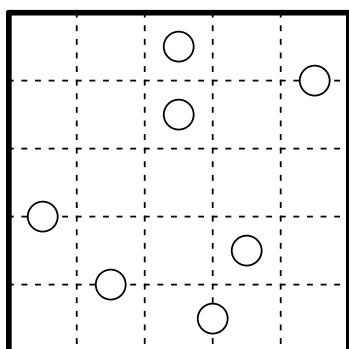

8.5 Araf

Divide the grid into regions of orthogonally connected cells. Each region must contain exactly two circles and have an area that lies between the two numbers in the circles, exclusive.

[Check Example → 2.1](#)

8.6 Slash Pack

Example from GP 2022 R3

Divide the grid into regions by adding diagonals into empty cells. Two diagonals cannot cross in one cell, and there can be no loose ends. Each region must contain each of the numbers exactly once.

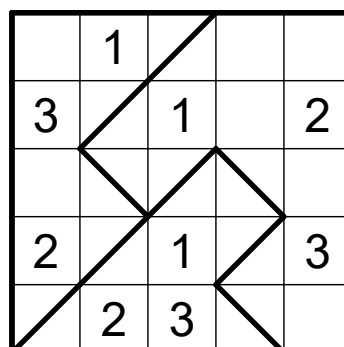
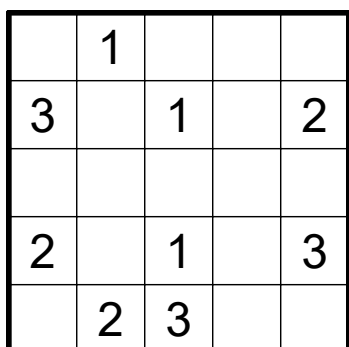

8.7 Pentominous

Divide the grid into regions of five orthogonally connected cells so that no two regions of the same shape share an edge, counting rotations and reflections as the same. Clued cells must belong to a region with the pentomino shape associated with that letter.

[Check Example → 1.1](#)

8.8 Snake Egg

Draw a snake (a 1 cell-wide path) in the grid whose head and tail are given by circled cells. The snake can touch itself diagonally, but cannot touch itself orthogonally or revisit any square. Besides the snake, the remaining cells must form exactly nine white areas, one of each size from 1 to 9 (1 to 5 in the example). Numbers in the grid must be part of white areas of the indicated size.

[Check Example → 5.6](#)

8.9 Tents

Example from GP 2022 R6

For each tree in the grid, place a tent in an empty orthogonally adjacent cell, connecting to it. Tents may not touch one another, not even diagonally. A clue given outside the grid represents the number of tents in the corresponding row or column.

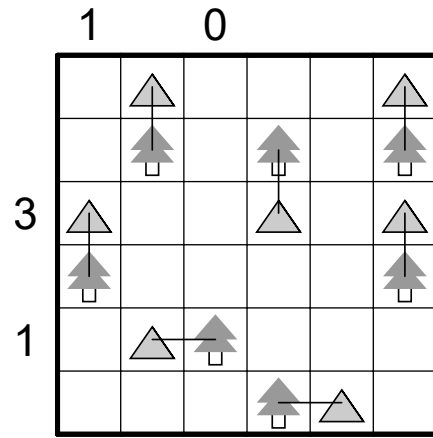
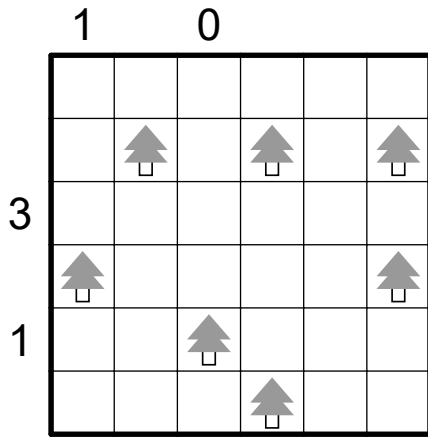

8.10 Anglers

Example by Martin Ender

From each number outside the grid, draw a path which immediately goes into the nearest cell of the grid and then travels through the centers of some cells until arriving at a fish. Paths may not cross themselves, each other, or fish. The number at the beginning of a path indicates how many cells in the grid the path occupies, including the cell with the fish.

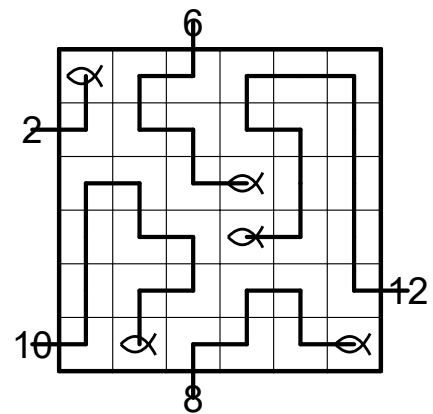
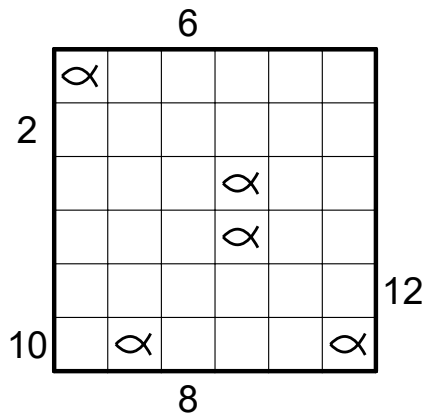

8.11 Castle Wall

Example by Thomas Snyder / gmpuzzles.com

Draw a non-intersecting loop through the centers of some cells. The loop may not enter outlined cells or cells containing clues. White cells with outlines must lie inside the loop, while black cells with outlines must lie outside the loop. Grey cells may either be inside or outside the loop. A number represents the sum of the lengths of loop segments in the indicated direction.

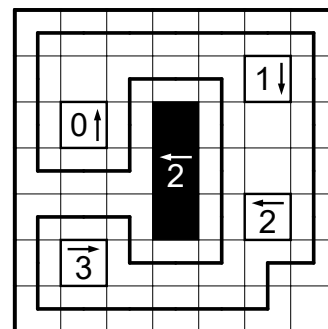
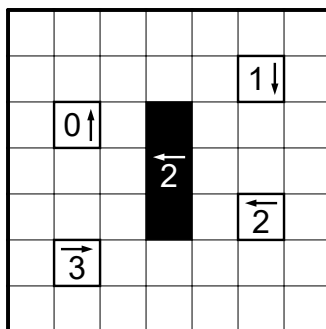

8.12 Irregular Sudoku

Example by Łukasz Bożykowski

Place a number from 1 to N into each empty cell so that each row, column, and bold region contains every number from that range with no repeats, where N is the side length of the grid.

3	4	1			6
5				3	
1			4		
		4			2
					3
			5	2	1

3	4	1	2	5	6
5	6	2	1	3	4
1	2	3	4	6	5
6	5	4	3	1	2
2	1	5	6	4	3
4	3	6	5	2	1

8.13 Skyscrapers

Example by Thomas Snyder / gmpuzzles.com

Place a number from 1 to N into each cell so that each row and column contains every number from that range with no repeats, where N is the side length of the grid. A clue outside the grid represents how many cells in the corresponding row or column contain a larger number than all cells before it in that row or column from the direction of the clue.

Clues: Top (3, 3, 3), Right (4, 4, 4), Bottom (5, 5), Left (2, 2, 2)

2	5	3	6	1	4	
2	1	6	2	5	4	3
	6	4	5	1	3	2
2	5	3	6	4	2	1
2	4	2	1	3	6	5
	3	1	4	2	5	6

Clues: Top (3, 3, 3), Right (4, 4, 4), Bottom (5, 5), Left (2, 2, 2)

8.14 X-Sums

Example by Martin Ender

Place a number from 1 to N into each cell so that each row and column contains every number from that range with no repeats, where N is the side length of the grid. A clue outside the grid indicates the sum of the first X numbers in the corresponding row or column from the direction of the clue, where X is the first number in that row or column from the direction of the clue

Clues: Top (5), Bottom (6), Left (9)

1	2	3	4	
4	3	1	2	
9	3	4	2	1
	2	1	4	3

Clues: Top (5), Bottom (6), Left (9)

8.15 Doppelblock

Example from GP 2022 R7

Place either a block or a number into each cell, so that each row and column contains exactly two blocks and exactly the same set of numbers as the one that is given. The numbers outside the grid indicate the sum of the numbers between the two blocks in that row or column. Some cells may already be filled in for you.

	2			0
4				
6				
5				

[1,2,3]

	2			0	
4	█	3	1	█	2
	2	1	█	█	3
6	█	2	3	1	█
5	1	█	2	3	█
	3	█	█	2	1

[1,2,3]

8.16 Cave

Shade some cells so that the shaded cells are all connected orthogonally by other shaded cells to the edge of the grid, and the remaining unshaded cells form one orthogonally connected area. Clues cannot be shaded, and represent the total number of unshaded cells that can be seen in a straight line vertically or horizontally, including itself.

[Check Example](#) → 1.5

8.17 Fillomino

Example from GP 2021 R7

Divide the grid into regions of orthogonally connected cells. Two regions of the same size may not share an edge. Clued cells must belong to a region containing the indicated number of cells.

8				1	4		
		2		4			
	2						4
			6			6	5
1	5			2			
4							1
			4		3		
		4	5				3

8				1	4		
		2		4			
	2						4
			6			6	5
1	5			2			
4							1
			4		3		
		4	5				3

8.18 Rail Pool

Draw a non-intersecting loop through the centers of all cells. Clues represent all of the different lengths of the straight line segments that are at least partially contained within the region. Each number within a region must be represented by at least one line segment. Each ? represents a positive integer, and numbers cannot repeat within a region.

[Check Example](#) → 3.17

8.19 Aqre

Shade some cells so that all shaded cells form one orthogonally connected area. Regions with numbers must contain the indicated amount of shaded cells. There may not exist a run of more than three consecutive shaded or unshaded cells horizontally or vertically anywhere in the grid.

[Check Example](#) → 3.1

8.20 Mochikoro

Example by Martin Ender

Shade some cells so that all areas of orthogonally connected unshaded cells are rectangular. The unshaded rectangles must all be connected diagonally. Clues cannot be shaded, and represent the number of cells in the unshaded area they belong to. An unshaded area of cells cannot contain more than one clue. No 2x2 region may be entirely shaded.

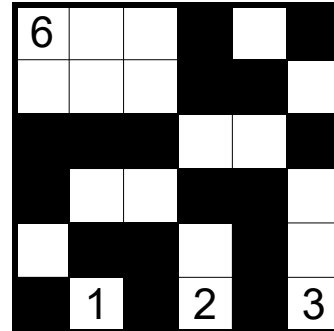
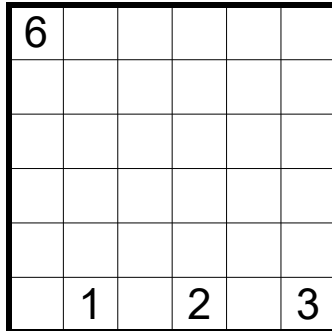

8.21 Norinori

Example by Psycho

Shade some dominoes of cells so that every region contains exactly two shaded cells. Shaded dominoes may not touch orthogonally.

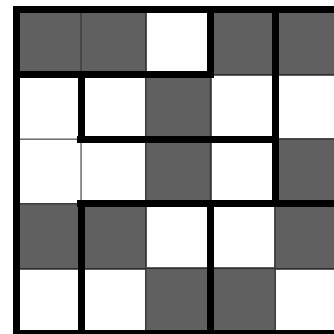
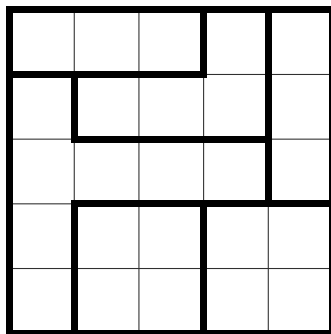

8.22 Geradeweg

Example by Martin Ender

Draw a non-intersecting loop through the centers of some cells that passes through every clue. Every straight line segment that touches a clue must have a length equal to the clue's value.

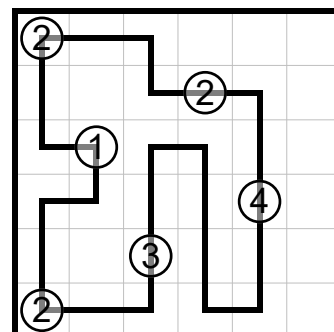
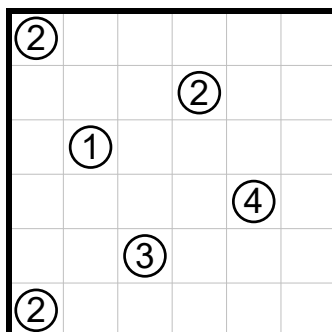

8.23 Slitherlink

Example from GP 2022 R7

Connect some pairs of orthogonally adjacent dots to form a single non-intersecting loop. Clues represent the number of edges drawn surrounding the clue.

[Check Example → 1.9](#)

8.24 Japanese Sums

Example from GP 2020 R6

Place a number from the given range into some cells so that no number is repeated in any row or column. Numbers outside the grid represent the sums of the numbers in blocks of consecutive numbered cells in the corresponding row or column, in order. Sums must be separated by at least one empty cell.

(1-7) 3 11 6

 13 2 19 1 24

7	8					
	18					
7	1	4				
	10	5				
	5	14				

(1-7) 3 11 6

 13 2 19 1 24

7	8	3	4		2	6	
	18		7	5	4	2	
7	1	4	7		1	4	
	10	5	1	2	7	5	
	5	14	5		6	1	7

8.25 Double Choco

Divide the grid into regions of orthogonally connected cells, each containing a connected group of white cells and a connected group of grey cells, with the property that the shape of the white cells is identical to the shape of the grey cells, allowing rotations and reflections. Clued cells must belong to a region containing the indicated number of white cells and the indicated number of grey cells.

[Check Example → 1.4](#)

8.26 Yajilin (Regions)

Shade some cells so that no two shaded cells are orthogonally adjacent and draw a non-intersecting loop through the centers of all the remaining cells. Numbered regions must contain the indicated amount of shaded cells.

[Check Example → 1.6](#)

8.27 Balance Loop

Example from gmpuzzles.com

Draw a non-intersecting loop through the centers of some cells that passes through every circle. The straight line segments coming out of a white circle must have equal length, while the straight line segments coming out of a black circle must have different lengths. A clue in a circle represents the sum of the lengths of these two line segments.

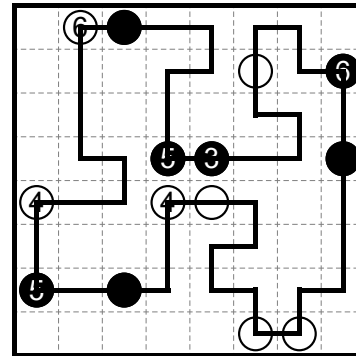
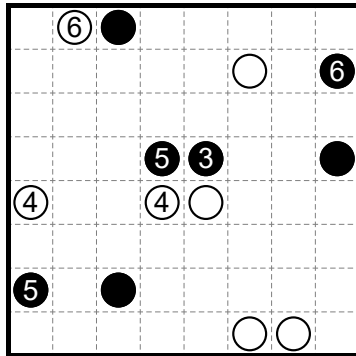

8.28 Statue Park

Example from GP 2022 R6

Place each shape from the bank given outside the grid into the grid so that no two shapes share an edge and all unused cells form one orthogonally connected area. Rotating and reflecting shapes is allowed. Cells with black circles must be used by a shape, and cells with white circles must not be used by a shape.

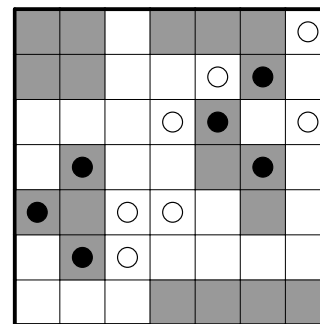
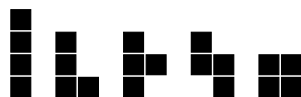
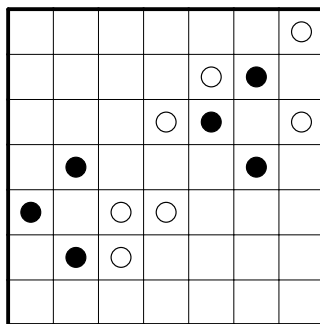

8.29 Kurotto

Example by Serkan Yürekli / gmpuzzles.com

Shade some cells so that each circled number represents the total count of shaded cells in connected groups sharing an edge with that number. Cells with circles cannot be shaded.

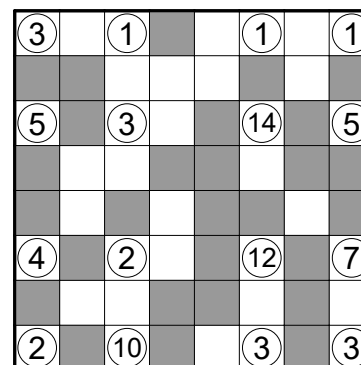
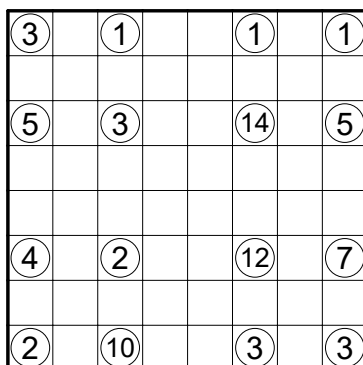

Round by

Sam Cappleman-Lynes

Puzzles

9.1-2 Heyawake65 + 95 Points
9.3-4 Pentopia25 + 80 Points
9.5-6 Yajilin30 + 45 Points
9.7-8 Shikaku40 + 45 Points
9.9-10 Shakashaka55 + 65 Points
9.11-12 Rassi Silai40 + 50 Points
9.13-14 Doppelblock60 + 60 Points

Round Information

For each puzzle, you are given two copies of the same grid which has multiple solutions. Your task is to find two solutions that are, in a particular sense, completely different.

9.1-2 Heyawake

Example by Sam Cappleman-Lynes

Follow standard Heyawake rules. No cell can be shaded in both solutions.

Heyawake: Shade some cells so that no two shaded cells are orthogonally adjacent and the remaining unshaded cells form one orthogonally connected area. Numbered regions must contain the indicated amount of shaded cells. A line of consecutive unshaded cells may not cross more than one bold border.

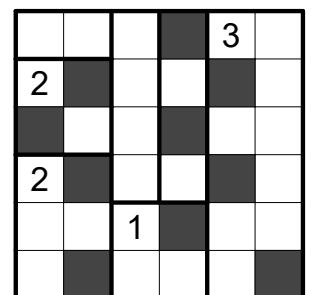
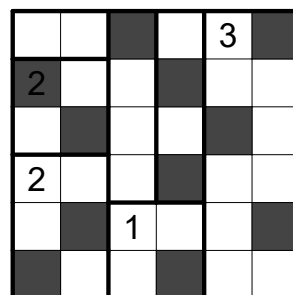
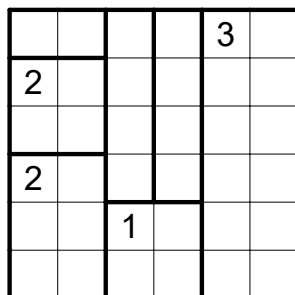
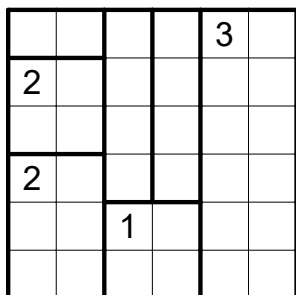

9.3-4 Pentopia

Example by Sam Cappleman-Lynes

Follow standard Pentopia rules. No pentomino shape can appear in both solutions, counting rotations and reflections as the same.

Pentopia: Shade some pentominoes of cells so that no pentominoes touch one another, not even diagonally. No two shaded pentominoes may be the same shape, counting rotations and reflections as the same. Clued cells cannot be shaded, and contain arrows indicating all of the orthogonal directions in which a shaded cell appears closest to the clued cell. At least one shaded cell must appear in the direction of an arrow.

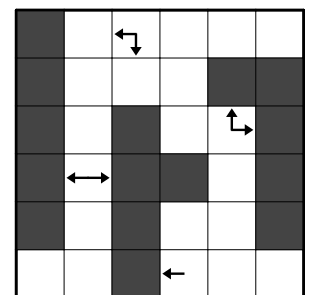
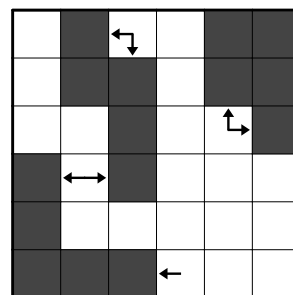
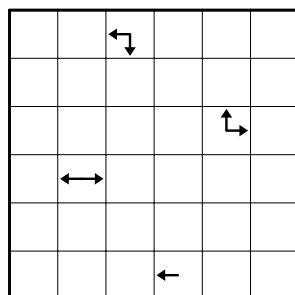
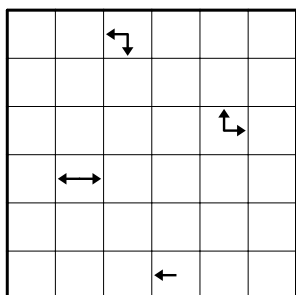

9.5-6 Yajilin

Example by Sam Cappleman-Lynes

Follow standard Yajilin rules. No cell can be shaded in both solutions.

Yajilin: Shade some cells so that no two shaded cells are orthogonally adjacent and draw a non-intersecting loop through the centers of all the remaining empty cells. Clues cannot be shaded, and represent the number of shaded cells in a straight line in the indicated direction.

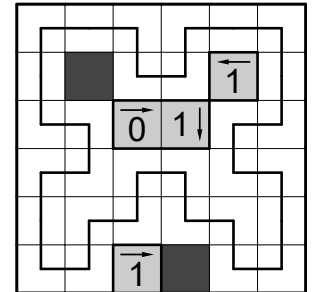
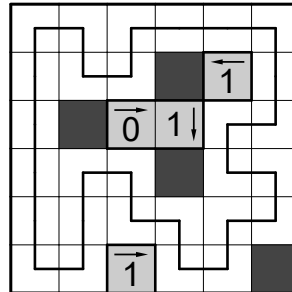
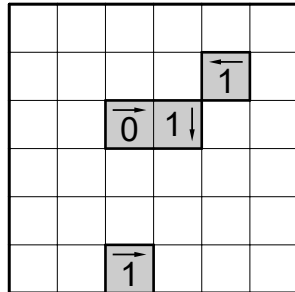
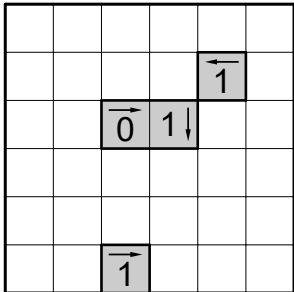

9.7-8 Shikaku

Example by Sam Cappleman-Lynes

Follow standard Shikaku rules. For each circle, the rectangles containing that circle in both solutions cannot have equal widths and equal heights; either the width or the height must be different from one solution to the other.

Shikaku: Divide the grid into rectangular regions of orthogonally connected cells. Each region must contain exactly one circle. A number in a circle represents how many cells are in the region the circle belongs to.

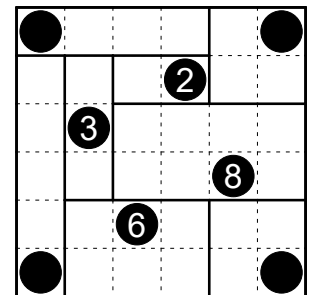
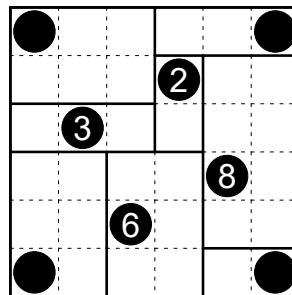
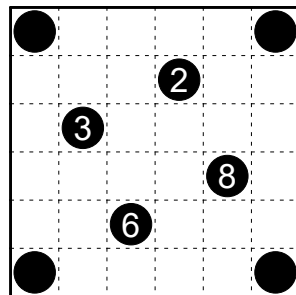
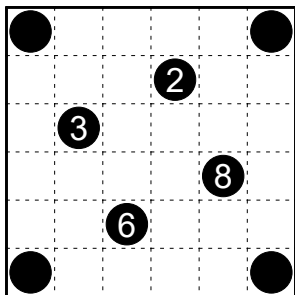

9.9-10 Shakashaka

Example by Sam Cappleman-Lynes

Follow standard Shakashaka rules. No cell can contain a triangle of the same orientation in both solutions.

Shakashaka: Shade a right triangle in some empty cells, each of which occupies exactly half the cell it's in. Each unshaded area must be rectangular in shape. A number in a cell represents how many of the (up to) four cells orthogonally adjacent to the clue contain triangles.

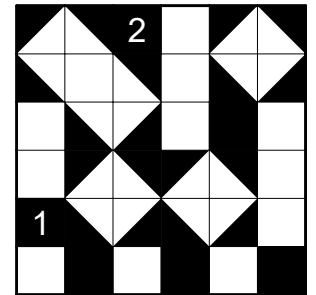
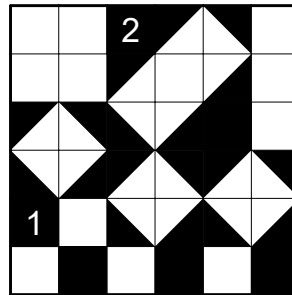
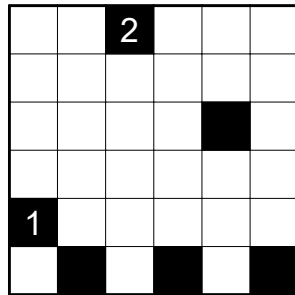
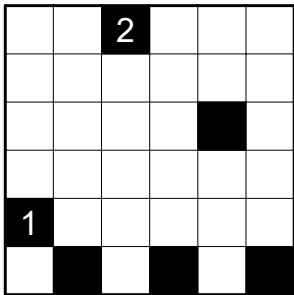

9.11-12 Rassi Silai

Example by Sam Cappleman-Lynes

Follow standard Rassi Silai rules. No cell can be an endpoint of a path in both solutions.

Rassi Silai: Within each region, draw a non-intersecting path through the centers of all cells. Paths may not cross over bold borders. No two cells in the grid containing endpoints of paths may be touching one another, not even diagonally.

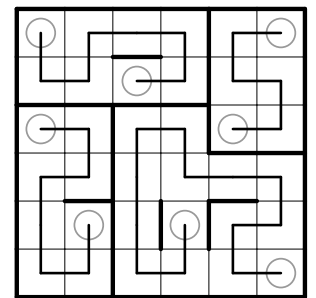
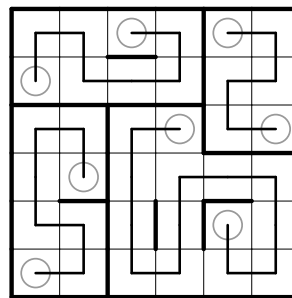
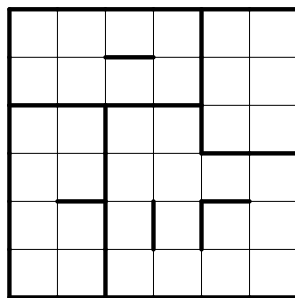
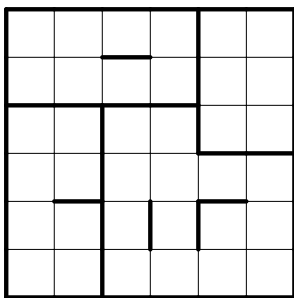

9.13-14 Doppelblock

Example by Sam Cappleman-Lynes

Follow standard Doppelblock rules. No cell can be shaded in both solutions and no cell can contain the same number in both solutions.

Doppelblock: Place either a block or a number into each cell, so that each row and column contains exactly two blocks and exactly the same set of numbers as the one that is given. The numbers outside the grid indicate the sum of the numbers between the two blocks in that row or column. Some cells may already be filled in for you.

	2			0
5				
1				

	2			0
5				
1				

{1,2,3}

	2			0
5		3	2	
	2			1
1		1		3
	3	2	1	
	1		3	2

	2			0
5	1		3	2
		1	2	3
1	2		1	
		3		1
	3	2		1

{1,2,3}

Round by

Eric Fox
Martin Ender
Psyho
Serkan Yürekli

Puzzles

10.1 Sudoku	30 Points
10.2-3 Hidato (Knight)	40 + 50 Points
10.4 Overlapping Squares	50 Points
10.5 Aqre	75 Points
10.6 Battleships (Loop)	55 Points
10.7 Meandering Numbers	25 Points
10.8 Tapa (Alternative)	70 Points
10.9 Statue Park	80 Points
10.10 Yajisan-Kazusan	40 Points
10.11 Country Road	35 Points
10.12 Nurikabe	50 Points

10.1 Sudoku

Example by Łukasz Bożykowski

Place a number from 1 to N into each empty cell so that each row, column, and bold region contains every number from that range with no repeats, where N is the size of the region.

1	2	3			
4					
5			4		
		1			6
					5
			1	2	3

1	2	3	5	6	4
4	6	5	2	3	1
5	3	6	4	1	2
2	4	1	3	5	6
3	1	2	6	4	5
6	5	4	1	2	3

10.2-3 Hidato (Knight)

Example from GP 2022 R7

Place a number from 1 to N into each cell so that every number appears once, where N is the total number of cells in the grid. Every number must be a knight's move away from all numbers in the grid that are consecutive with it.

Note: In order to receive credit for the puzzle, it's enough to either place all numbers **or** draw a complete path.

				21
			5	
	13	18		
	2			

23	4	11	16	21
12	17	22	5	10
3	24	9	20	15
8	13	18	1	6
25	2	7	14	19

10.4 Overlapping Squares

Example by Martin Ender

Trace some gridlines to draw squares in the grid. Exactly one square must exist of each size within the range given outside the grid. The sides of different squares may intersect each other, but not turn at their intersection or otherwise overlap. A clue indicates the sum of the side lengths of the squares which contain the clue.

					1
4					
		7			

					1
4					
		7			

10.5 Aqre

Fully shade some square cells (marked with thin boundaries) so that all shaded cells form one orthogonally connected area. There may not exist a run of more than three consecutive shaded or unshaded cells horizontally or vertically anywhere in the grid. Numbers in bold regions indicate the total shaded area within that region, assuming each grid cell has an area of 1.

[Check Example → 3.1](#)

10.6 Battleships (Loop)

Example by Serkan Yürekli

Standard Battleships rules. In addition, draw a non-intersecting loop through the centers of all cells not occupied by ships. Some loop segments might be already given.

Battleships: Place the given fleet of ships into the grid so that no two ships are touching, not even diagonally. Rotating ships is permitted. A clue outside the grid indicates the number of cells in the corresponding row or column that are occupied by ships. Cells with waves cannot be occupied by a ship. A given ship segment must be used as the part of a ship that its shape represents.

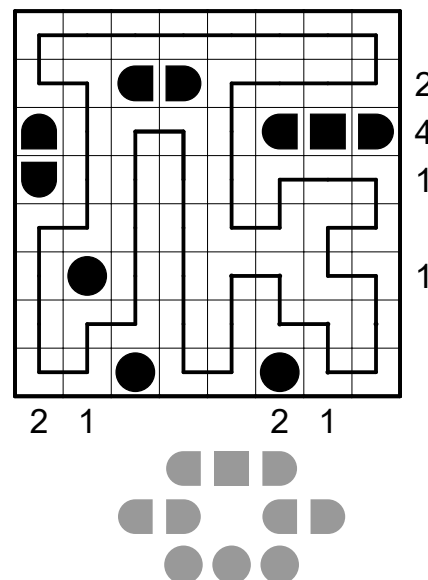
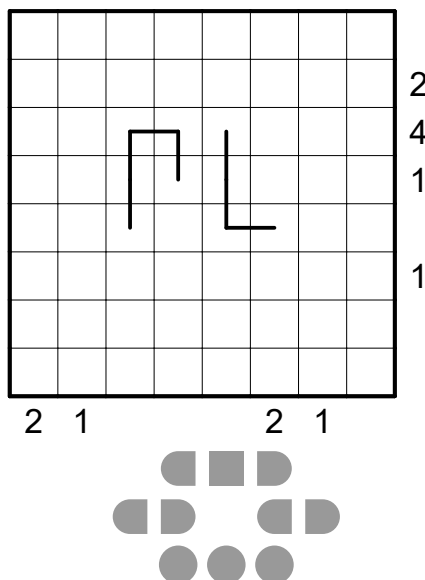

10.7 Meandering Numbers

Example by Eric Fox

Place a number into each cell so that each region contains an edge-connected chain of consecutive numbers from 1 to N, where N is the number of cells in the region. Numbers of the same value may not touch one another.

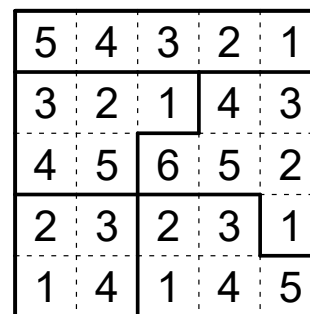
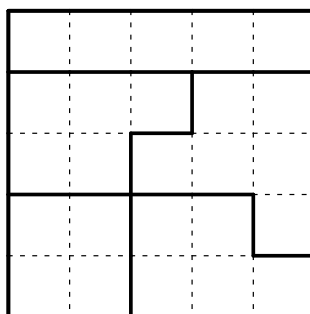

10.8 Tapa (Alternative)

Example by Serkan Yürekli

Shade some cells so that all shaded cells form one orthogonally connected area. Numeric clues cannot be shaded, and represent the lengths of the blocks of consecutive shaded cells in the (up to) eight cells surrounding the clue. For each set of identical letter clues, exactly one is shaded and the others are not. No 2x2 region may be entirely shaded.

A	C	E	2			Y
P	O	L	A	N	D	
A				2 ₄		
T		W	P	C		
	2 ₄					W
	D	N	A	L	O	P
S			3	W	P	C

A	C	E	2			Y
P	O	L	A	N	D	
A				2 ₄		
T		W	P	C		
	2 ₄					W
	D	N	A	L	O	P
S			3	W	P	C

10.9 Statue Park

Place each shape from the bank given outside the grid into the grid so that no two shapes share an edge and all unused cells form one orthogonally connected area. Rotating and reflecting shapes is allowed. Cells with black circles must be used by a shape, and cells with white circles must not be used by a shape.

[Check Example](#) → 8.28

10.10 Yajisan-Kazusan

Example by Serkan Yürekli / gmpuzzles.com

Shade some cells so that no two shaded cells are orthogonally adjacent and the remaining unshaded cells form one orthogonally connected area. If a cell with a number in it is unshaded, the number represents how many shaded cells are in a straight line in the indicated direction. If a cell with a number in it is shaded, the number is meaningless.

		0	2		4
			1	2↓	
	1↑				2↓
		3↑	2		
	0		3	2	

		0	2		4
			1	2↓	
	1↑				2↓
		3↑	2		
	0		3	2	

10.11 Country Road

Draw a non-intersecting loop through the centers of some cells which enters and exits each region exactly once. A number in a region represents how many cells in the region are visited by the loop. Orthogonally adjacent cells across a thick border may not both be unused.

[Check Example](#) → 1.2

10.12 Nurikabe

Shade some cells so that all shaded cells form one orthogonally connected area. Clues cannot be shaded, and every orthogonally connected area of unshaded cells contains exactly one clue, the value of which represents the size of the area. No 2x2 region may be entirely shaded.

[Check Example](#) → 4.3

Round by

Michał Stajszczak

Puzzles

11.1 Makaro	30 Points
11.2 Easy as ABC	70 Points
11.3 Skyscrapers	80 Points
11.4 Fuzuli	110 Points
11.5 Tents	25 Points
11.6 Battleships (Knight Loop)	65 Points
11.7 Star Battle	70 Points

11.1 Makaro

Example by Michał Stajszczak

Standard Makaro rules. In addition, two of the same number may not be a knight's move apart.

Makaro: Place a number into each empty cell so that each region contains the numbers from 1 to N with no repeats, where N is the number of cells in the region. Numbers of the same value may not touch one another orthogonally. Each arrow must point to a number which is larger than all other numbers orthogonally adjacent to the arrow.

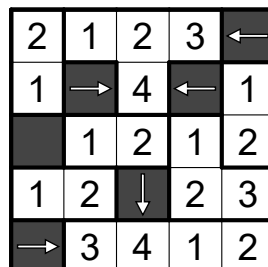
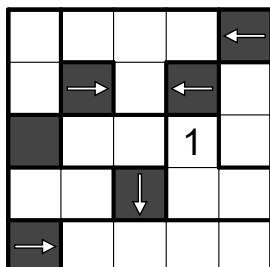

11.2 Easy as ABC

Example by Michał Stajszczak

Standard Easy as ABC rules. In addition, two of the same letter may not be a knight's move apart.

Easy as ABC: Place letters from the ABCD (AB in the example) set into some cells so that each row and column contains each letter once. A clue outside the grid represents the first letter seen in the corresponding row or column from that direction.

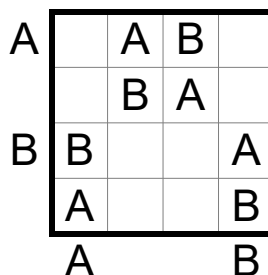
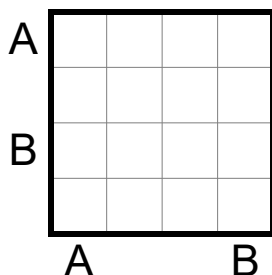

11.3 Skyscrapers

Example by Michał Stajszczak

Standard Skyscrapers rules. In addition, two of the same number may not be a knight's move apart.

Skyscrapers: Place a number from 1 to N into each cell so that each row and column contains every number from that range with no repeats, where N is the side length of the grid. A clue outside the grid represents how many cells in the corresponding row or column contain a larger number than all cells before it in that row or column from the direction of the clue.

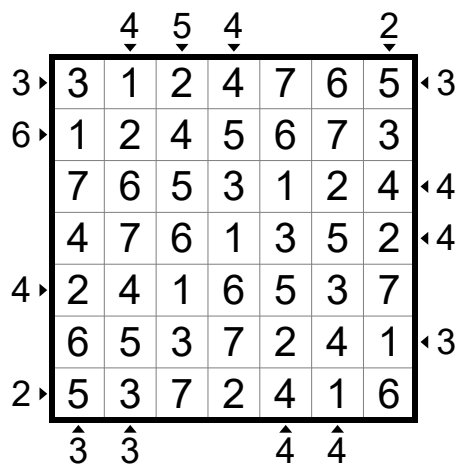
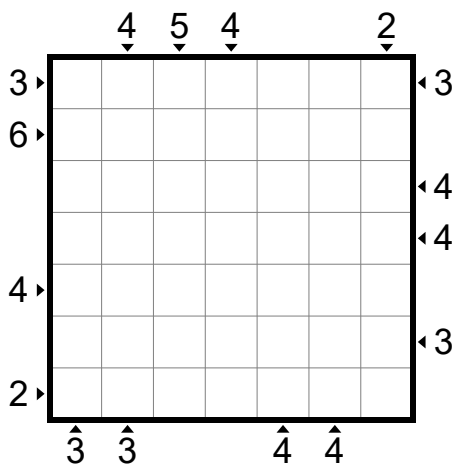

11.4 Fuzuli

Example by Michał Stajszczak

Standard Fuzuli rules. In addition, two of the same number may not be a knight's move apart.

Fuzuli: Place letters from the 1-5 (1-3 in the example) given outside the grid into some empty cells so that each row and column contains each letter once. No 2x2 group of cells may be entirely filled with letters.

	1		2	
			3	

	3	1		2
3	1		2	
1		2		3
	2		3	1
2		3	1	

11.5 Tents

Example by Michał Stajszczak

Standard Tents rules. In addition, two tents may not be a knight's move apart.

Tents: For each tree in the grid, place a tent in an empty orthogonally adjacent cell, connecting to it. Tents may not touch one another, not even diagonally. A clue given outside the grid represents the number of tents in the corresponding row or column.

●			●	
	●			
			●	

●	▲		●	▲
	●			
	▲		●	▲

11.6 Battleships (Knight Loop)

Example by Michał Stajszczak

Standard Battleships rules. In addition, draw a loop connecting centers of the cells, and each two consecutive centers are a knight's move apart. The loop must visit every cell occupied by a ship exactly once and cannot visit any other cells.

Battleships: Place the given fleet of ships into the grid so that no two ships are touching, not even diagonally. Rotating ships is permitted. A clue outside the grid indicates the number of cells in the corresponding row or column that are occupied by ships. Cells with waves cannot be occupied by a ship. A given ship segment must be used as the part of a ship that its shape represents.

Note: In order to receive credit for the puzzle, you need to place the fleet **and** draw the loop.

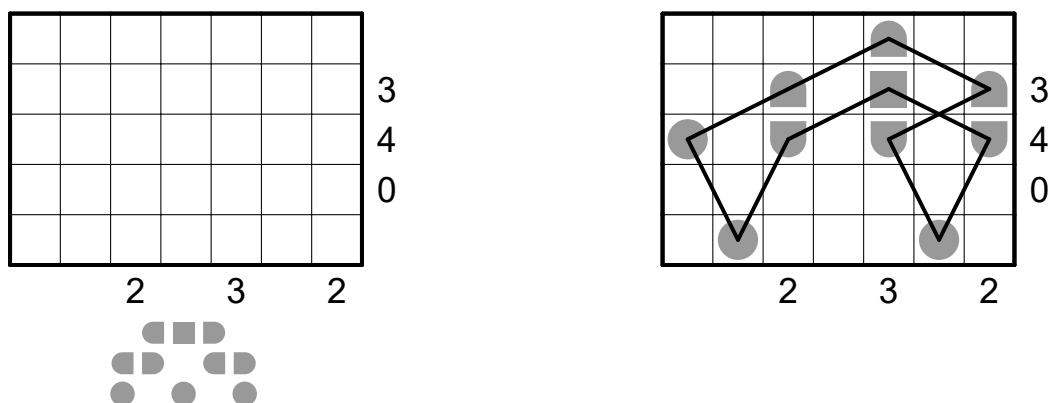

11.7 Star Battle

Example by Michał Stajszczak

Standard Star Battle rules. In addition, two stars may not be a knight's move apart.

Star Battle: Place stars into some cells such that each row, column, and outlined region contains exactly 2 (1 in the example) stars. Stars may not touch one another, not even diagonally.

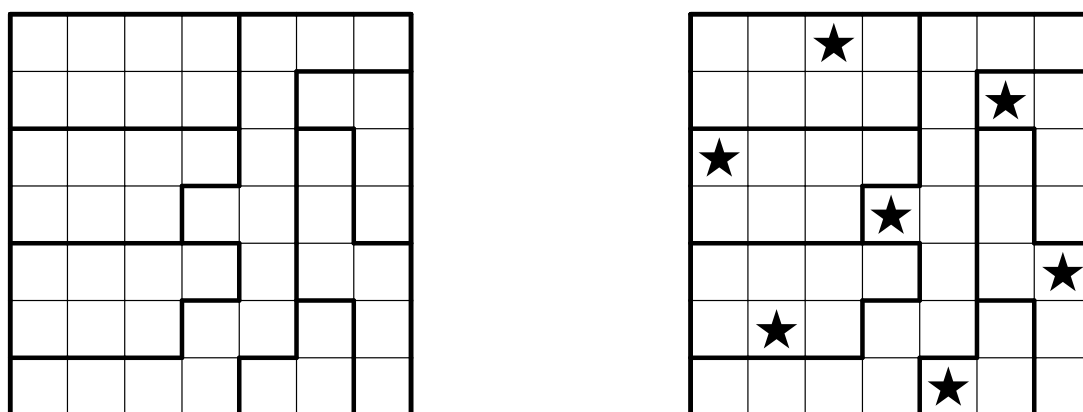

Round by

Tom Coward

Puzzles

12.1 Aqre (Borders)	15 Points
12.2-3 Tapa	20 + 30 Points
12.4 Nurikabe	35 Points
12.5 Fillomino	25 Points
12.6-7 Slitherlink	35 + 60 Points
12.8 Cave	70 Points
12.9 Kuromasu	30 Points
12.10 Shimaguni	50 Points
12.11 Nurimisaki	40 Points
12.12 Mochinyoro	40 Points

12.1 Aqre (Borders)

Example by Tom Coward

Shade some cells so that all shaded cells form one orthogonally connected area. A pair of cells separated by a bold border must contain one shaded cell and one unshaded cell. There may not exist a run of more than three consecutive shaded or unshaded cells horizontally or vertically anywhere in the grid.

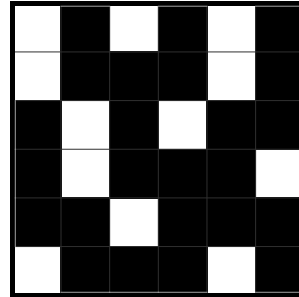
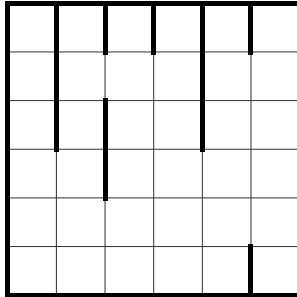

12.2-3 Tapa

Example by Tom Coward

Standard Tapa rules. In addition, there may not exist a run of more than three consecutive shaded or unshaded cells horizontally or vertically anywhere in the grid. Clued cells are considered unshaded.

Tapa: Shade some cells so that all shaded cells form one orthogonally connected area. Clues cannot be shaded, and represent the lengths of the blocks of consecutive shaded cells in the (up to) eight cells surrounding the clue. No 2x2 region may be entirely shaded.

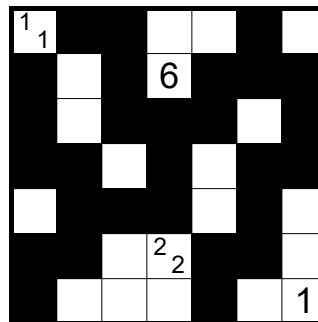
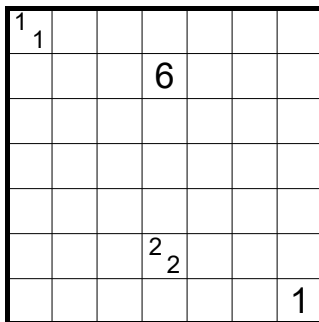

12.4 Nurikabe

Example by Tom Coward

Standard Nurikabe rules. In addition, there may not exist a run of more than three consecutive shaded or unshaded cells horizontally or vertically anywhere in the grid. Clued cells are considered unshaded.

Nurikabe: Shade some cells so that all shaded cells form one orthogonally connected area. Clues cannot be shaded, and every orthogonally connected area of unshaded cells contains exactly one clue, the value of which represents the size of the area. No 2x2 region may be entirely shaded. Each ? represents a positive integer.

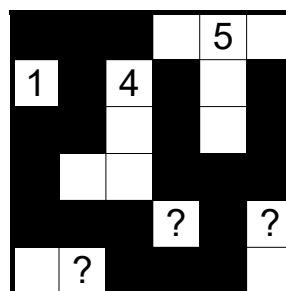
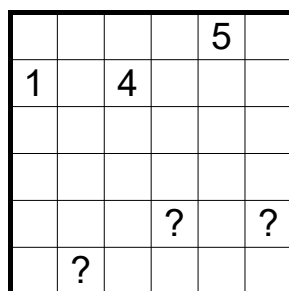

12.5 Fillomino

Example by Tom Coward

Standard Fillomino rules. In addition, no region may contain a run of more than three consecutive cells horizontally or vertically.

Fillomino: Divide the grid into regions of orthogonally connected cells. Two regions of the same size may not share an edge. Clued cells must belong to a region containing the indicated number of cells.

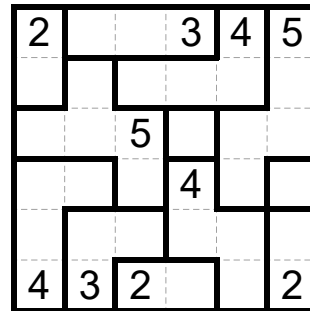
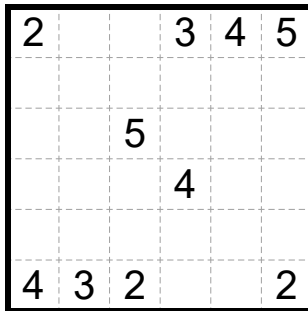

12.6-7 Slitherlink

Example by Tom Coward

Standard Slitherlink rules. In addition, there may not exist a run of more than three consecutive cells in a row or column, either all inside or all outside the loop.

Slitherlink: Connect some pairs of orthogonally adjacent dots to form a single non-intersecting loop. Clues represent the number of edges drawn surrounding the clue.

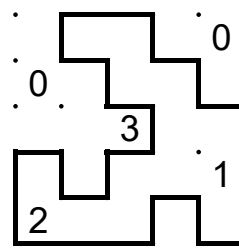
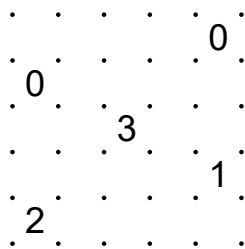

12.8 Cave

Example by Tom Coward

Standard Cave rules. In addition, there may not exist a run of more than three consecutive shaded or unshaded cells horizontally or vertically anywhere in the grid.

Cave: Shade some cells so that the shaded cells are all connected orthogonally by other shaded cells to the edge of the grid, and the remaining unshaded cells form one orthogonally connected area. Clues cannot be shaded, and represent the total number of unshaded cells that can be seen in a straight line vertically or horizontally, including itself.

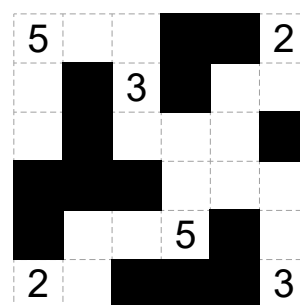
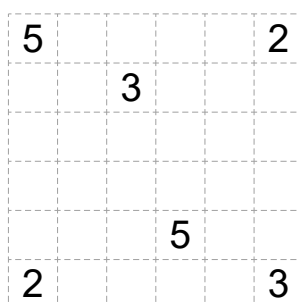

12.9 Kuromasu

Example by Tom Coward

Standard Kuromasu rules. In addition, there may not exist a run of more than three consecutive shaded or unshaded cells horizontally or vertically anywhere in the grid.

Kuromasu: Shade some cells so that no two shaded cells are orthogonally adjacent and the remaining unshaded cells form one orthogonally connected area. Clues cannot be shaded, and represent the total number of unshaded cells that can be seen in a straight line vertically or horizontally, including itself.

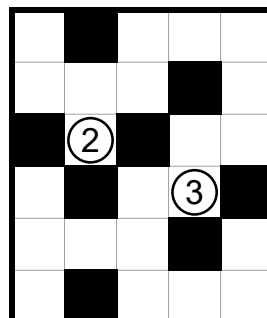
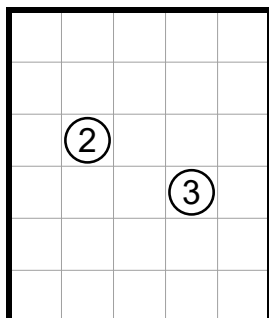

12.10 Shimaguni

Example by Tom Coward

Standard Islands rules. In addition, there may not exist a run of more than three consecutive shaded or unshaded cells horizontally or vertically anywhere in the grid.

Islands: Shade a single group of orthogonally connected cells in each region. Shaded groups may not share a bold border. Regions with numbers must contain the indicated amount of shaded cells. Each region must contain at least one shaded cell, and no two adjacent regions may contain the same number of shaded cells.

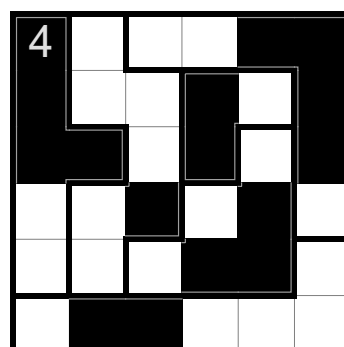
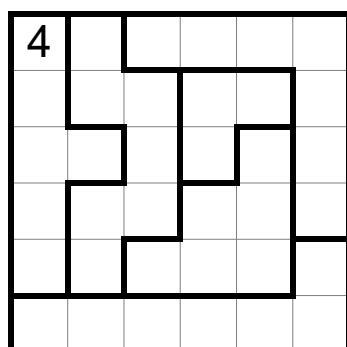

12.11 Nurimisaki

Example by Tom Coward

Standard Nurimisaki rules. In addition, there may not exist a run of more than three consecutive shaded or unshaded cells horizontally or vertically anywhere in the grid.

Nurimisaki: Shade some cells so that the remaining unshaded cells form one orthogonally connected area. No 2x2 region may be entirely shaded or unshaded. Circles mark every instance of a cell which is unshaded and orthogonally adjacent to exactly one other unshaded cell. If a circle contains a number, it indicates how many cells are in the straight line of unshaded cells coming out of the cell with the circle, including itself.

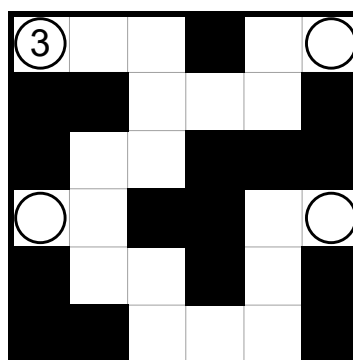
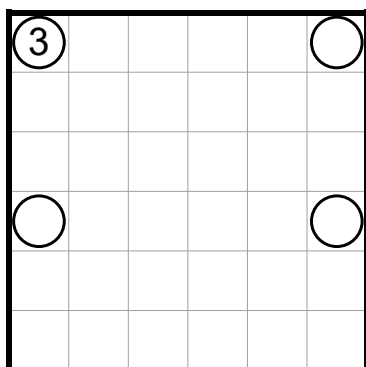

12.12 Mochinyoro

Example by Tom Coward

Standard Mochinyoro rules. In addition, there may not exist a run of more than three consecutive shaded or unshaded cells horizontally or vertically anywhere in the grid.

Mochinyoro: Shade some cells so that all areas of orthogonally connected unshaded cells are rectangular and all areas of orthogonally connected shaded cells are not rectangular. The unshaded rectangles must all be connected diagonally. Clues cannot be shaded, and represent the number of cells in the unshaded area they belong to. An unshaded area of cells cannot contain more than one clue. No 2x2 region may be entirely shaded.

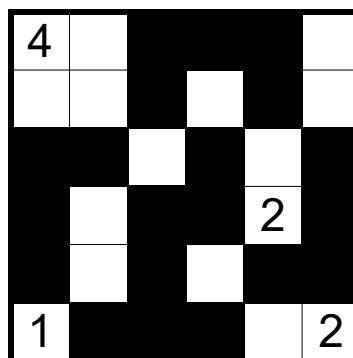
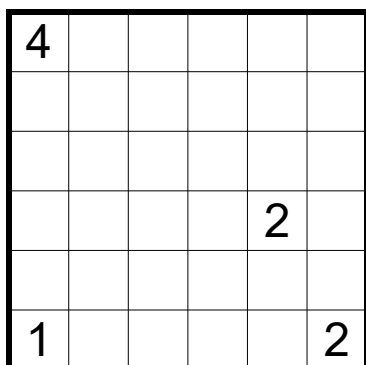

Round by

Arvi Teikari
 JinHoo Ahn
 Martin Ender
 Serkan Yürekli
 Tomasz Stańczak

Puzzles

13.1 Araf (Line)70 Points
13.2 Kropki (Toroidal)70 Points
13.3 Castle Wall80 Points
13.4 Celltinels	80 Points
13.5 Five Cells (Dislocated Clues)80 Points
13.6 Yajilin (Transparent)80 Points
13.7 Star Battle (Loop)80 Points
13.8 Limited Alike	110 Points
13.9 Fillomino (Checkered)110 Points
13.10 Inverse LITSO	110 Points
13.11 Rail Pool (Forgetful)	130 Points

13.1 Araf (Line)

Divide the grid into regions of orthogonally connected cells. Each region must contain exactly two circles and have an area that lies between the two numbers in the circles, exclusive. No region may contain a line of more than three consecutive cells horizontally or vertically.

[Check Example → 2.4](#)

13.2 Kropki (Toroidal)

Example by JinHoo Ahn

Standard Kropki rules. In addition, the grid is toroidal, which means that the first and the last rows/columns are considered adjacent.

Kropki: Place a number from 1 to N into each cell so that each row and column contains every number from that range with no repeats, where N is the side length of the grid. All pairs of orthogonally adjacent cells containing numbers with a 1:2 ratio are marked with a black dot. All pairs of orthogonally adjacent cells containing consecutive numbers are marked with a white dot. A 1 next to a 2 may be marked with either dot.

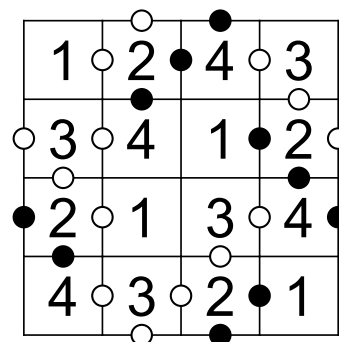
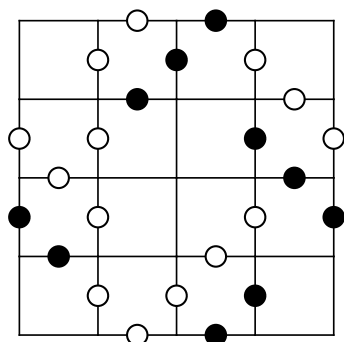

13.3 Castle Wall

Draw a non-intersecting loop through the centers of some cells. The loop may not enter outlined cells or cells containing clues. White cells with outlines must lie inside the loop, while black cells with outlines must lie outside the loop. Grey cells may either be inside or outside the loop. A number represents the sum of the lengths of loop segments in the indicated direction.

[Check Example → 8.11](#)

13.4 Celltinels

Shade some cells to form a non-intersecting loop which does not touch itself, not even diagonally. Clues cannot be shaded, and represent the total number of shaded cells that appear in a straight line vertically or horizontally from the clue. Clues cannot see through other clues. Empty gray squares represent a clue that doesn't convey any additional information.

[Check Example → 3.25](#)

13.5 Five Cells (Dislocated Clues)

Example by JinHoo Ahn

Divide the grid into five cell regions. The clue numbers in the intersection indicate how many of the four edges connected to the point should be drawn.

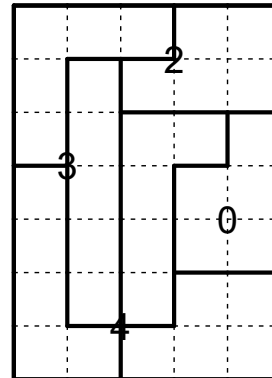
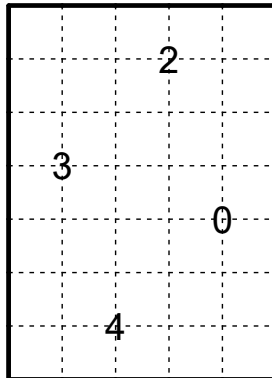

13.6 Yajilin (Transparent)

Example by Prasanna Seshadri / gmpuzzles.com

Shade some cells so that no two shaded cells are orthogonally adjacent and draw a non-intersecting loop through the centers of all the unshaded cells, even ones with clues. If a cell with a number in it is unshaded, the number represents how many shaded cells are in a straight line in the indicated direction. If a cell with a number in it is shaded, the number is meaningless.

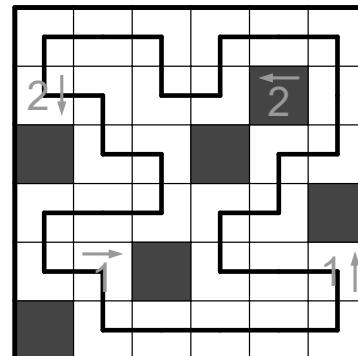
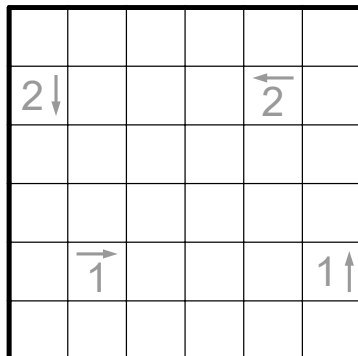

13.7 Star Battle (Loop)

Example by Tomasz Stańczyk

Place stars into some unshaded cells such that each row, column, and outlined region contains exactly 2 (1 in the example) stars and draw a non-intersecting loop through the centers of all remaining unshaded cells. Stars may not touch one another, not even diagonally.

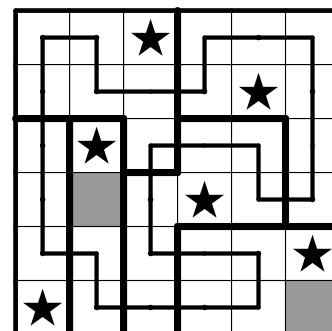
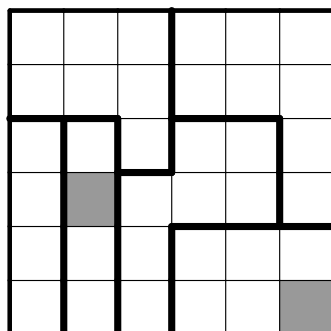

13.8 Limited Alike

Shade an orthogonally connected group of at least one cell within each region such that all shaded cells form one orthogonally connected area with no loops. No 2x2 area may be entirely shaded. A number indicates how many cells are shaded within its region. No two regions which share an edge may contain the same number of shaded cells. For any number X, a maximum of X regions may contain exactly X shaded cells.

[Check Example → 3.29](#)

13.9 Fillomino (Checked)

Example from gmpuzzles.com

Divide the grid into regions of orthogonally connected cells. Two regions of the same size may not share an edge, and it must be possible to shade some regions such that no two shaded regions or two unshaded regions share an edge. Clued cells must belong to a region containing the indicated number of cells.

Note: Shading is used for clarity only, you don't have to shade your solution.

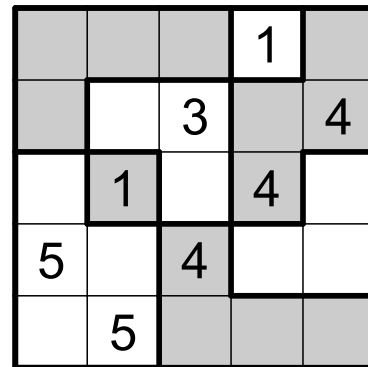
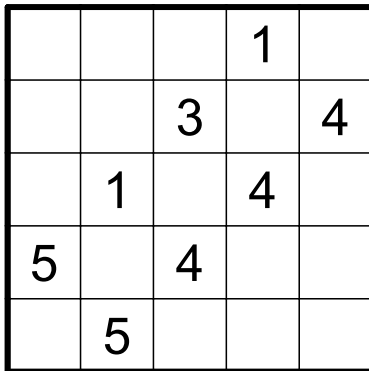

13.10 Inverse LITSO

Example from GP 2018 R7

Shade some cells black so that in each region there are exactly four unshaded cells that form an L, I, T, S, or O tetromino. When two unshaded tetrominoes share an edge across regions, they must not be the same shape regardless of rotations or reflections. All shaded cells must be connected into a single group, but no 2x2 group of cells can be entirely shaded black.

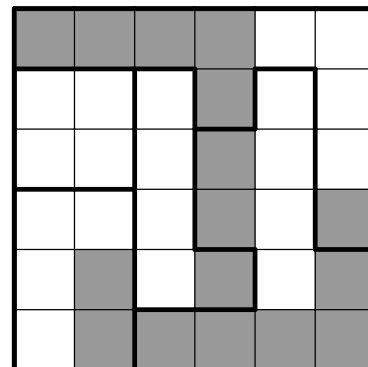
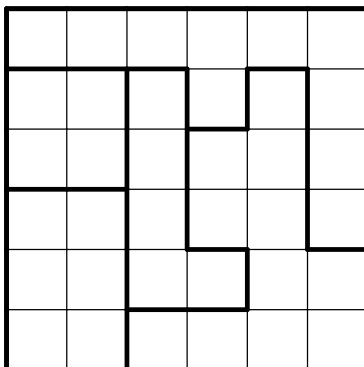

13.11 Rail Pool (Forgetful)

Example by Martin Ender

Draw a non-intersecting loop through the centers of all cells, except for exactly one in each region. Clues represent all of the different lengths of the straight line segments that are at least partially contained within the region. Each number within a region must be represented by at least one line segment. Each ? represents a positive integer, and numbers cannot repeat within a region.

