

# PERSPECTIVE

Tim Foster  
fostert6@wwu.edu  
Western Washington University  
Industrial Design 310  
Perspective and Rendering Fall 2019

This booklet will explore techniques and examples of perspective drawing, utilizing minimal drawing aids (rulers, templates, etc.) in order to build hand sketching muscle memory and skill.

# TABLE OF CONTENTS

|                                       |    |
|---------------------------------------|----|
| 1, 2, & 3 Point Perspectives          | 4  |
| Multiplying & Dividing                | 10 |
| Auxiliary & Multiple Vanishing Points | 12 |
| Ellipses                              | 15 |
| Shading                               | 26 |
| Shadows                               | 28 |
| Bio                                   | 32 |

# 1 POINT PERSPECTIVE

- All vertical & horizontal lines remain so
- Depth lines recede to a single Vanishing Point (VP) on the Horizon line
- Useful for Interior spaces

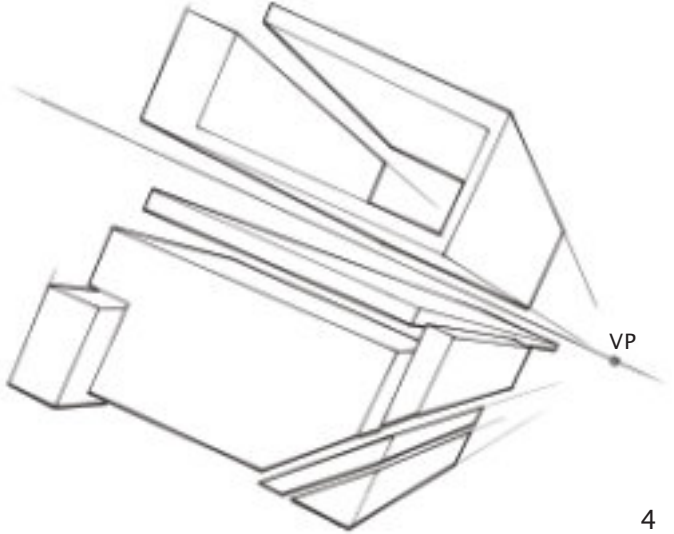

# OFFICE INTERIOR

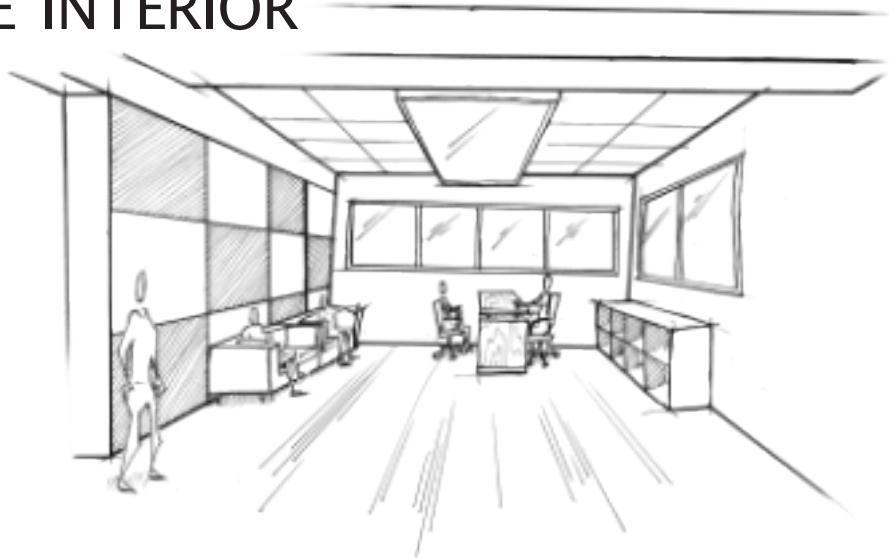

# 2 POINT PERSPECTIVE

- All vertical lines remain vertical
- Depth lines recede to 2 Vanishing Points on Horizon line
- Most common perspective for Industrial Design

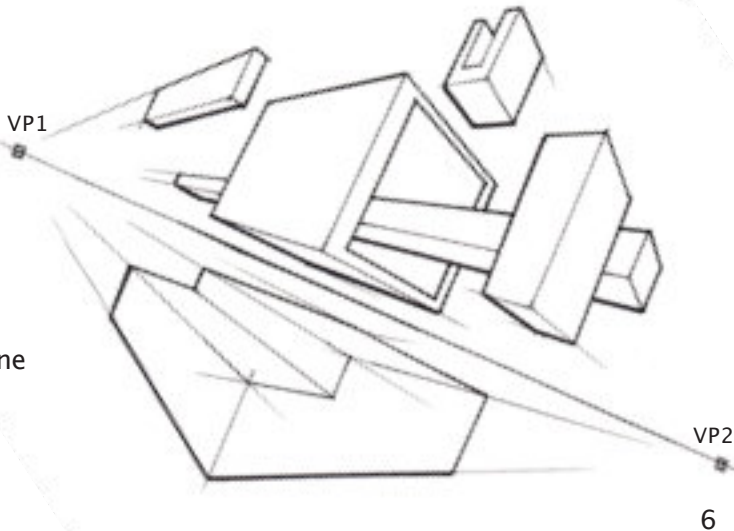

# PRINTER

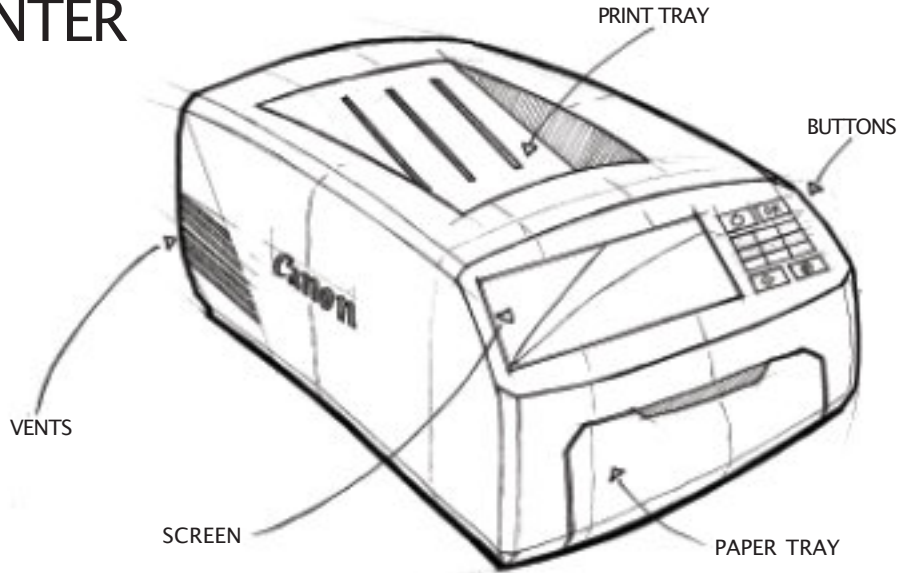

# 3 POINT PERSPECTIVE

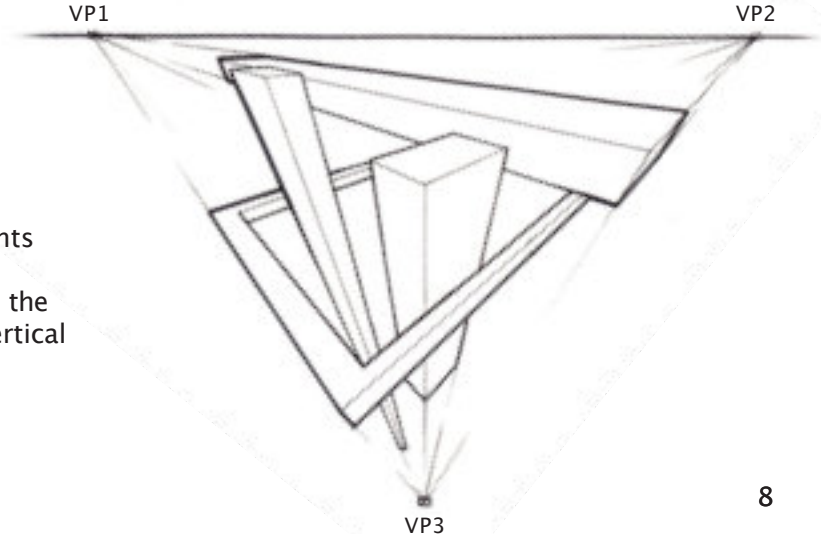

-All lines recede to their respective vanishing points

-2 vanishing points lie on the horizonline, the VP for vertical lines does not

-Prone to distortion

# MODERN HOUSE

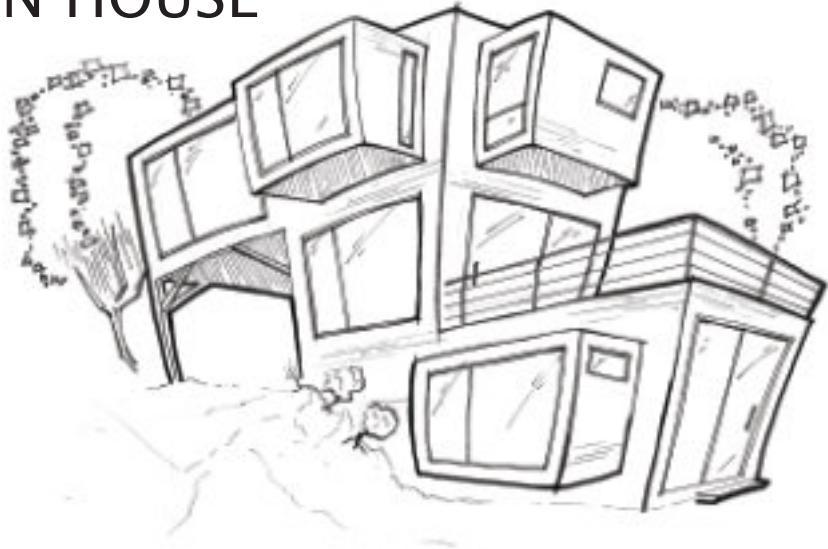

# MULTIPLICATION

-Use corners of cube to find middle lines



-Draw lines from corner of cube through the midpoint of the opposite edge to find corners of new cube

-Use vanishing points to finish new cube

# DIVISION

-Use corners of cube to find midpoints



-Use middle lines to define edges of subtracted cube

-Use Vanishing Points to finish

# MODULAR FURNITURE

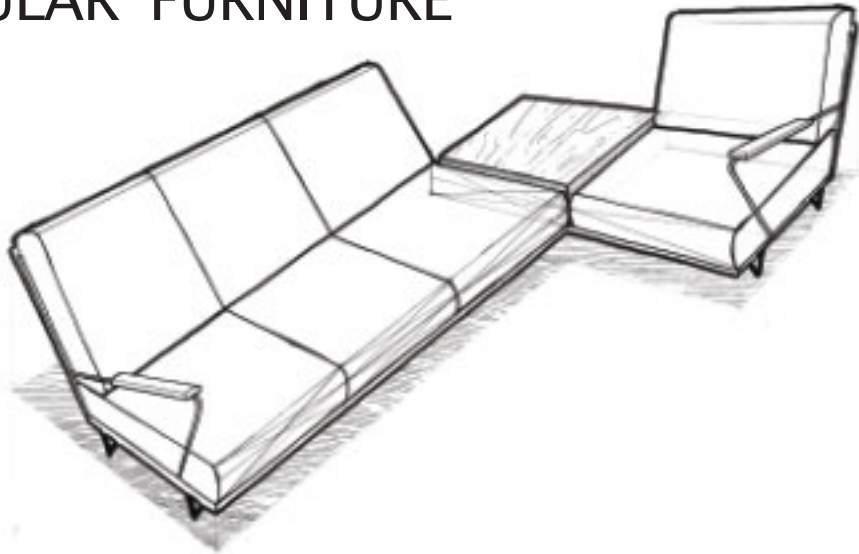

# MULTIPLE & AUXILIARY VPs

- Multiple vanishing points show different perspectives within the same environment
- Distances between VP's remain the same
- 1 object can only go to 1 set of VPs

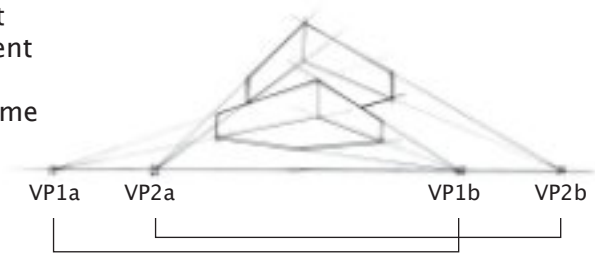
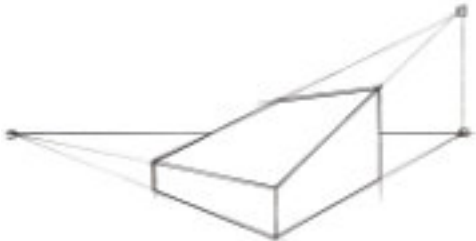

- Auxiliary vanishing points show are use for tilted surfaces
- Auxiliary VP's lie on a vertical line to an existing vanishing point

# MID-CENTURY DESK



# LAPTOP

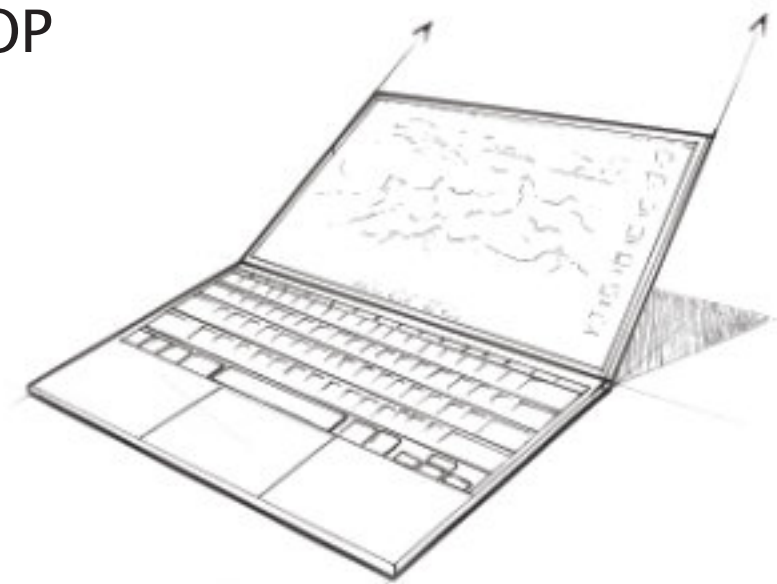

# ELLIPSES

-An ellipse is a circle drawn in perspective

-The degree of the ellipse is determined by the angle from which the circle is viewed

-The short axis is the minor axis and the long axis is the major axis

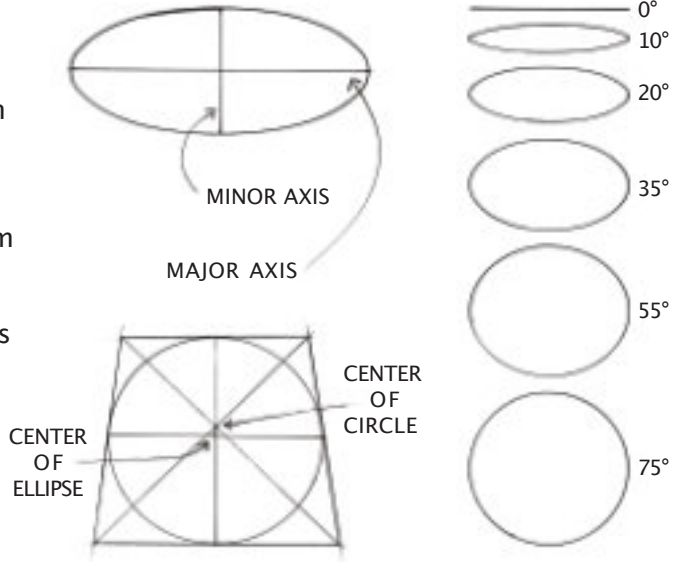

# WHEELED VEHICLE SKETCHES

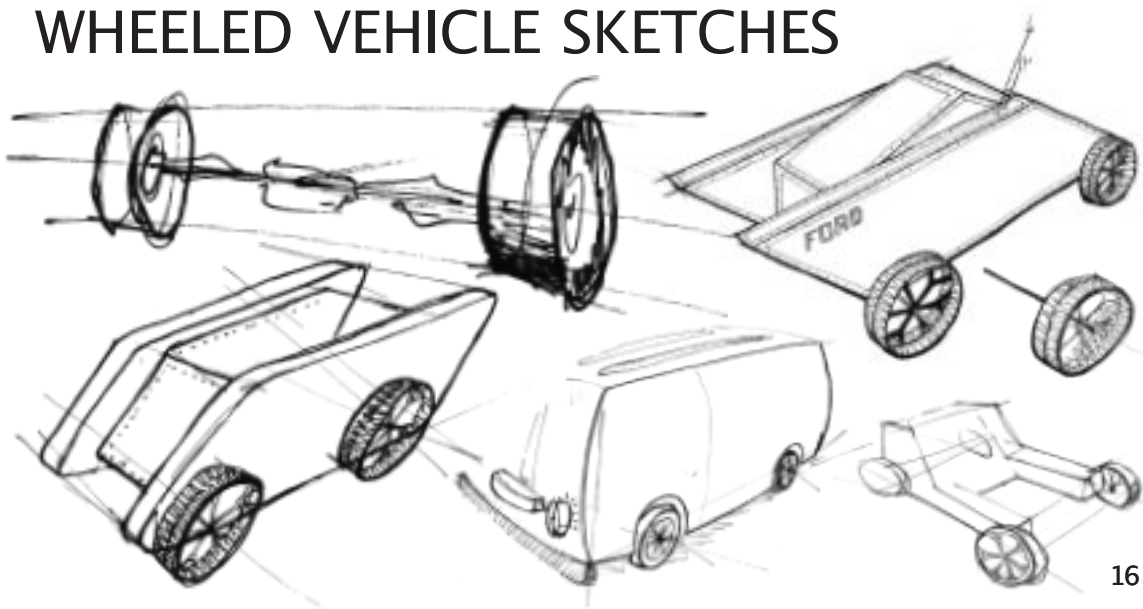

# SOMME

## SPACE DRONE

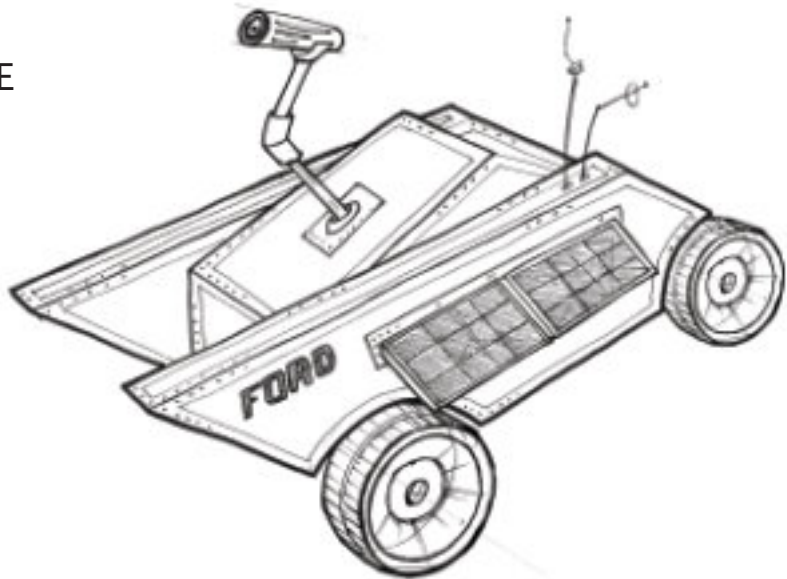

# GLASSWARE SKETCHES



# GLASSWARE SET



# DRILL CONCEPT SKETCHES

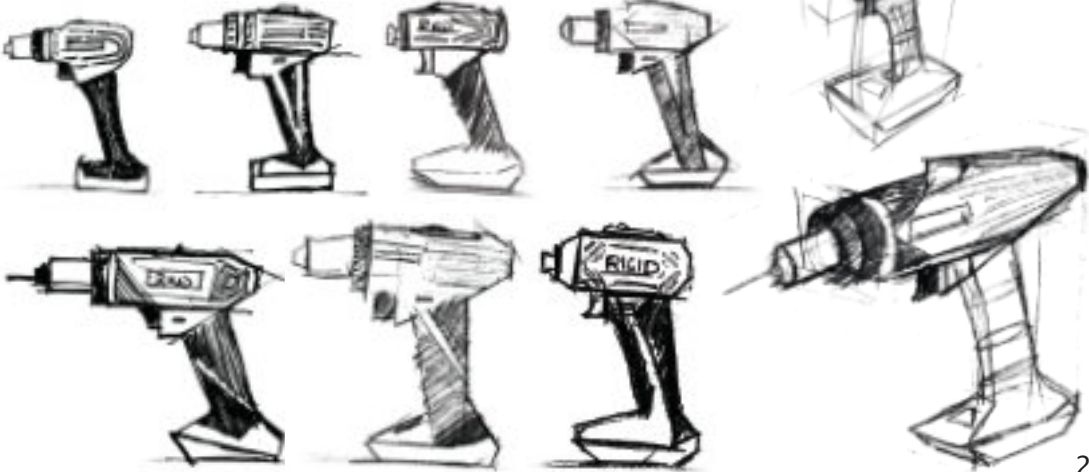

# CORDLESS DRILL

BY RIDGID

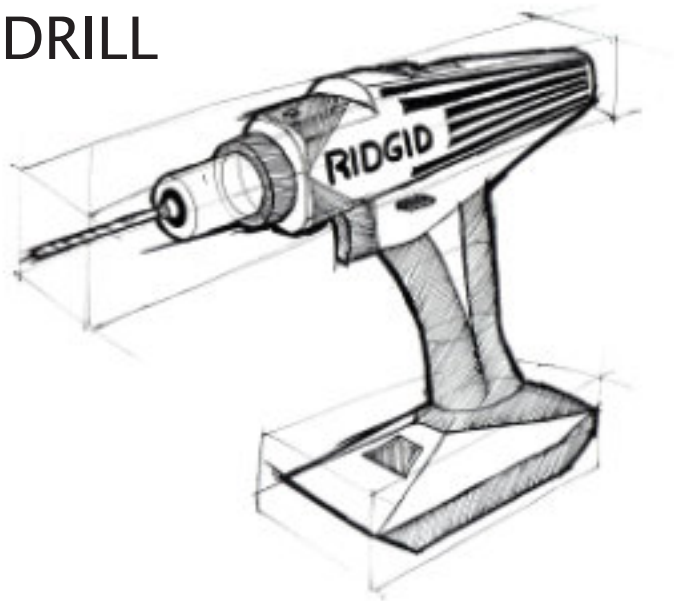

# IMPACT DRIVER

BY RIDGID



# FLYING VEHICLE CONCEPTS

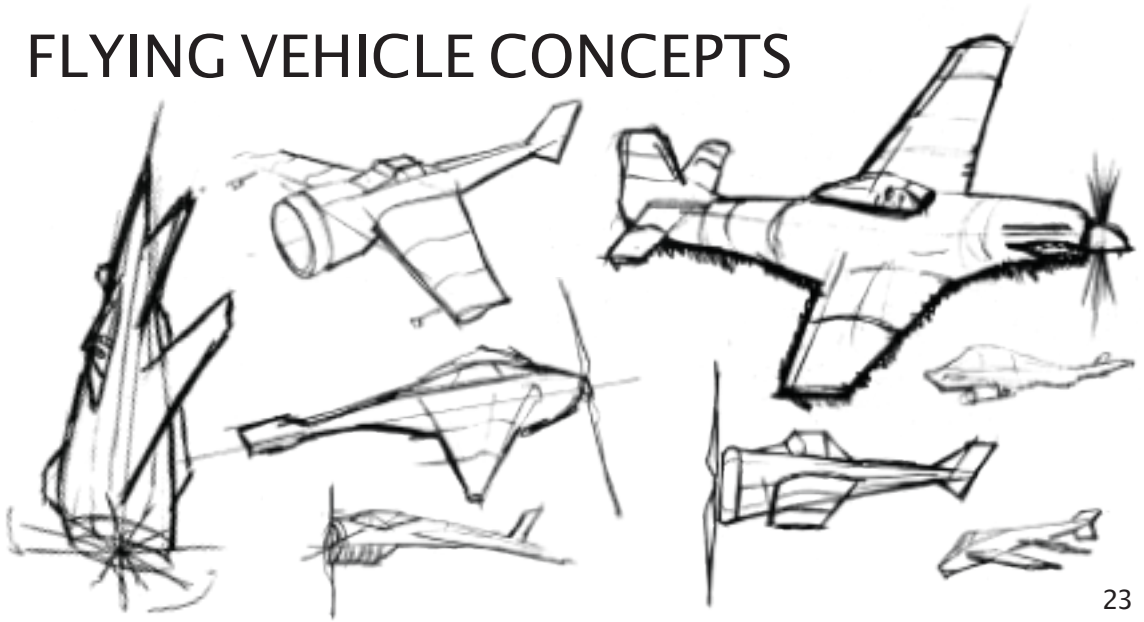

# FIGHTER PLANE

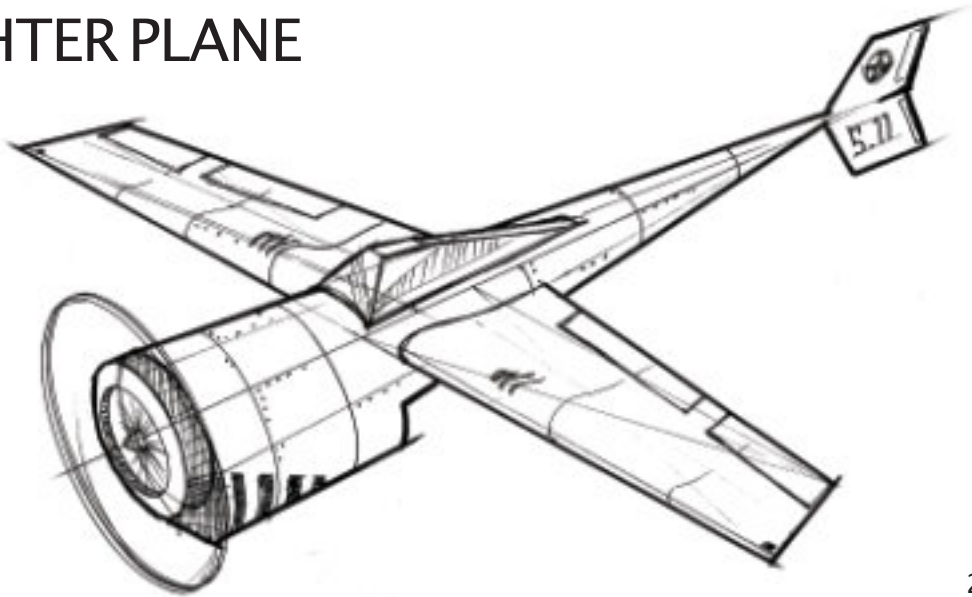

# CRUISERJET

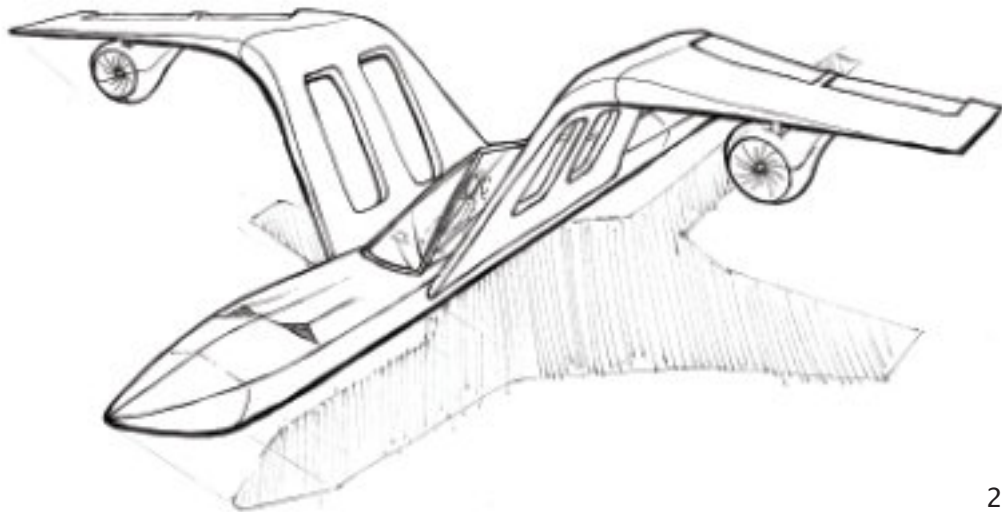

# SHADING EXPLANATION

- Choose lightsource (upper left as default)
- Determine surface's relation to the light
- Shade accordingly using various levels of darkness

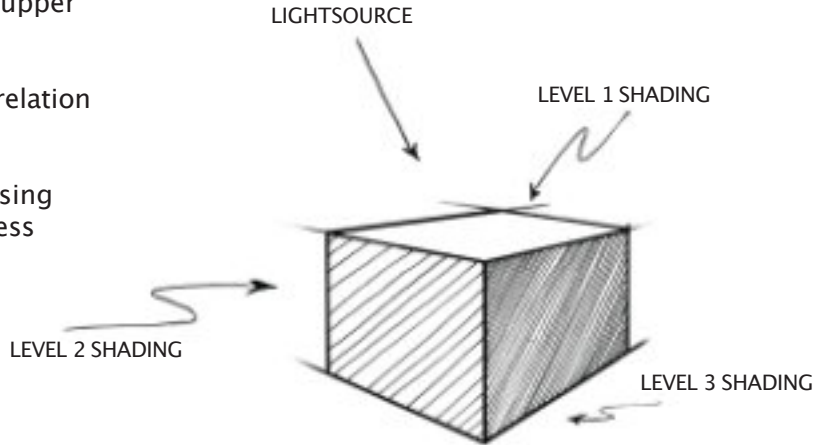

# SHADING EXAMPLES

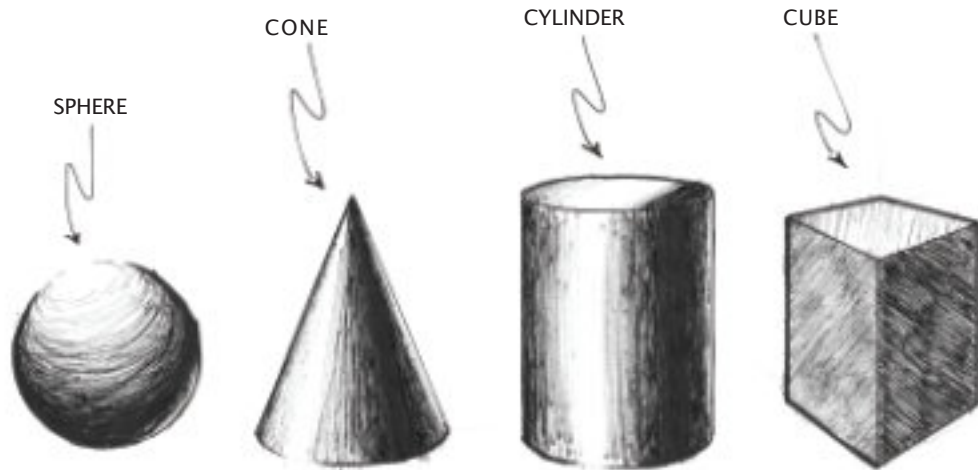

# SHADOW EXPLANATION

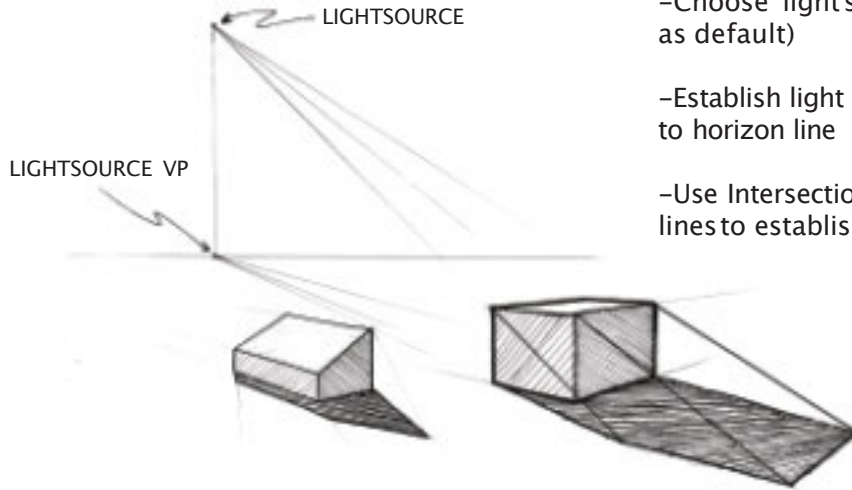

-Choose light source (upper left as default)

-Establish light source in relation to horizon line

-Use Intersections of vanishing lines to establish shadows

# SHADOW EXAMPLES

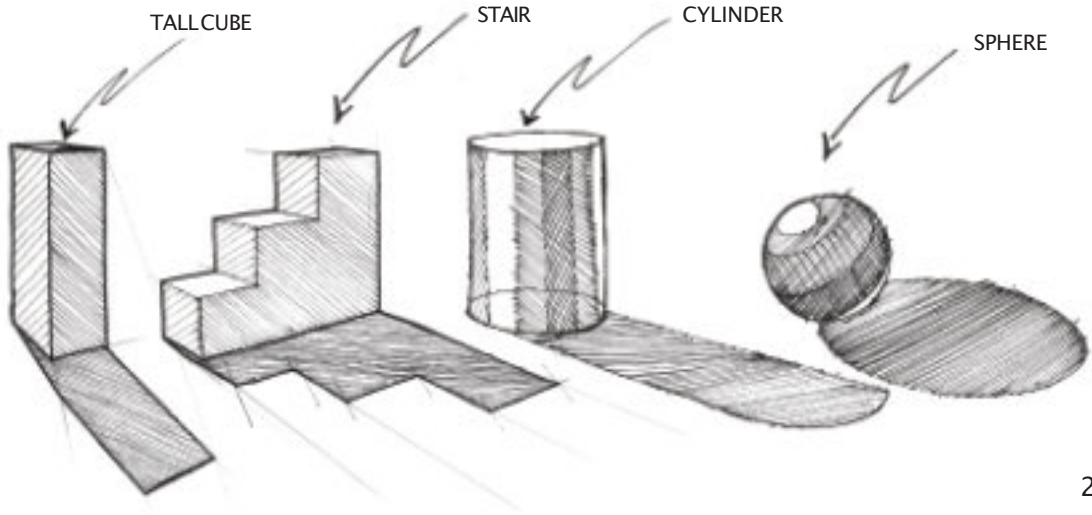

# REFLECTION EXPLANATION

-Draw shape & reflective surface

-Use diagonal lines from corners of surface facing the reflection to find distance

-Use surface of reflection as mid-point to find the reflection's size

VERTICAL

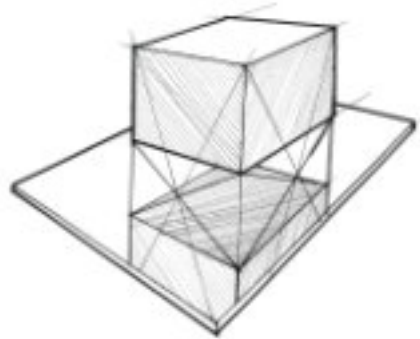
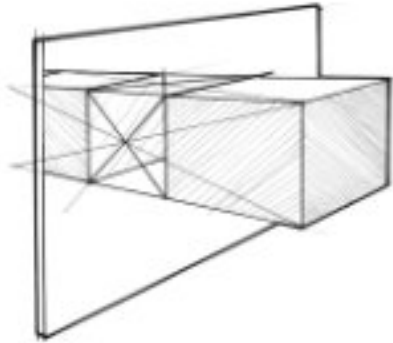

HORIZONTAL

# REFLECTION EXAMPLES

VERTICAL, 2 POINT

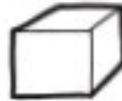
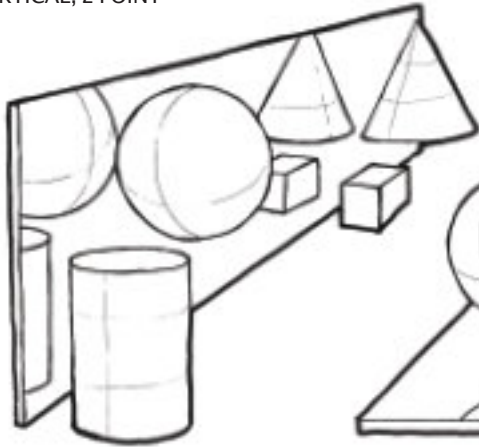

HORIZONTAL, 1 POINT



# CAMERA IDEATION

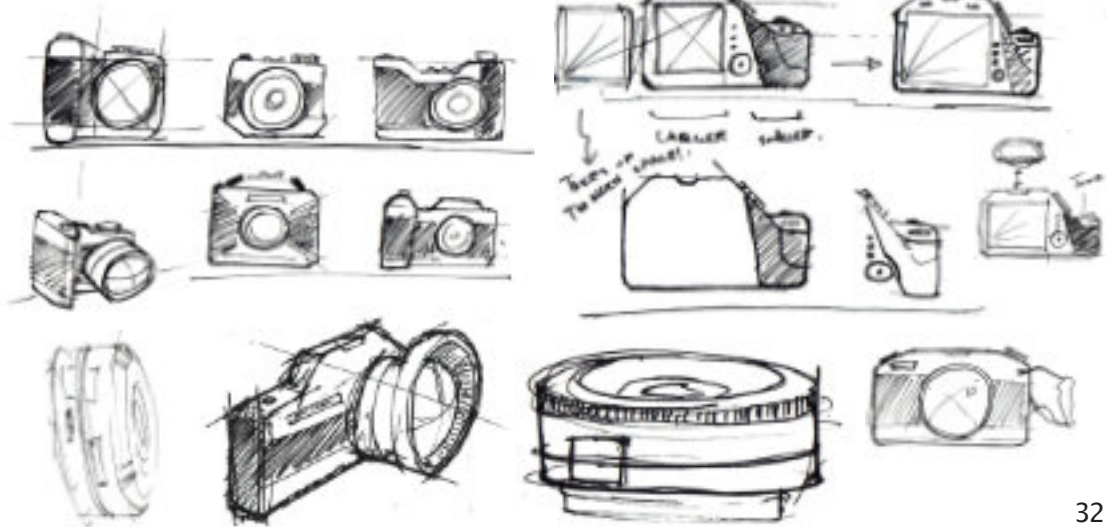

# R-11CAMERA

BY CANON

