



Supplied labels

Label Specs

- Kraft wrap in 250 packs
- Use 80# C1S paper stock
- Pallet must be stretched wrapped
- Please supply a 10% overrun of labels
- Multiple items require individual palettes
- A label should be displayed on outside of pallet
- Aqueous coating preferred, unless otherwise stated
- Label packs must be sandwiched between stiff, solid board, and corner supports suggested.

Label Sizes

The trim size of the labels is very important, and varies according to the demands of your order. Please refer to your customer service rep to determine your size specifications. The sizes will be determined by the machinery (the General or the Pot Devin) used during manufacturing.

A: The General

Labels must be trimmed 1/4" away from each side of the structure. Bleeds must be extended 1/2" beyond the structure to ensure full coverage of the bleed color/ graphics after trimming.

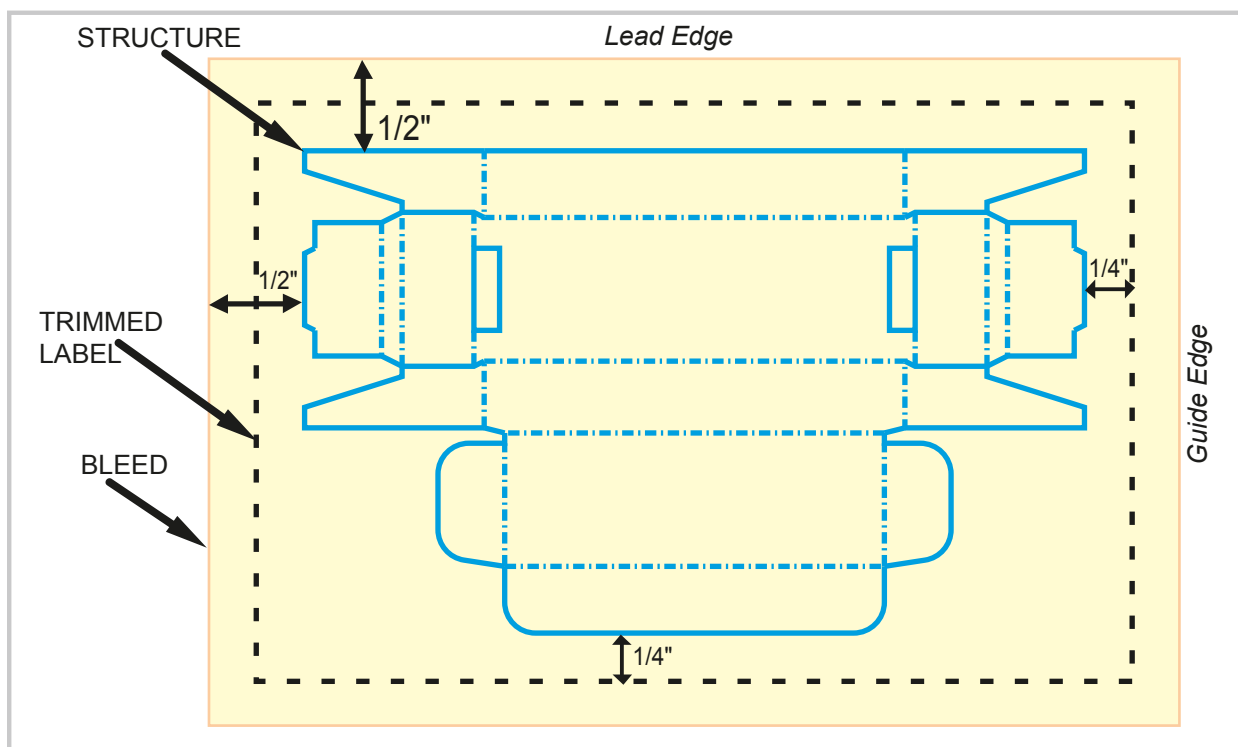

* We reserve the right to reject any supplied labels which do not conform to our guidelines.



B: The Pot Devin

Labels must be trimmed so that there is 1/2" on the lead and guide edges, and 5/8" on the other two sides, past the structure. Art, should have a minimum of 1/4" bleeds. Please refer to your customer service rep to determine the lead and guide edges. A structural mylar may be provided.

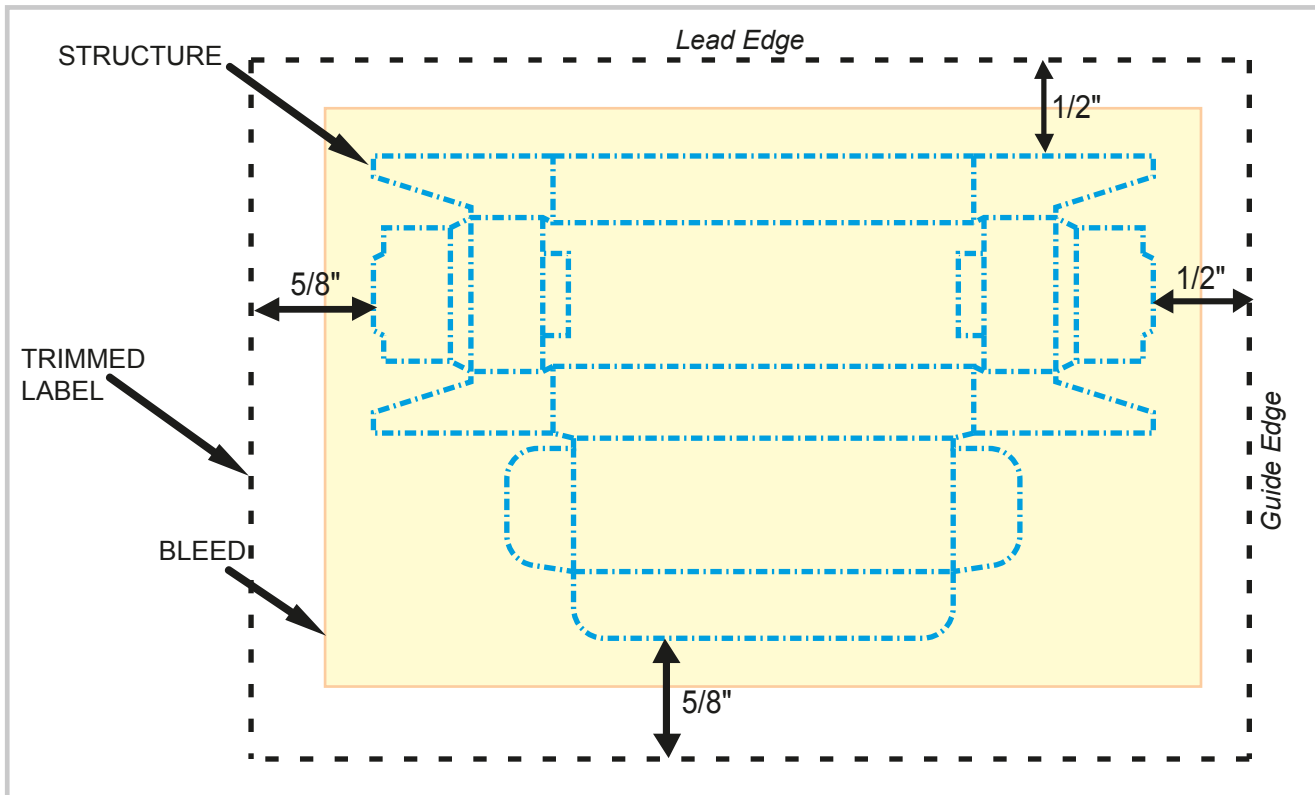

Tips to remember:

- Avoid having aqueous coating on areas to be glued (ie: glue tabs, auto bottom panels, etc.)
- Keep all graphic elements 1/4" away from edges and scores. Have background or colored areas bleed at least 1/4" past the die lines. If the graphic elements are not to bleed over, then keep them 1/4" within the die lines, on every panel.
- Use a mylar for placement of graphics in relationship to the structure. We recommend placing a mylar on top of a digital proof, align the structure, and then outline some of the main graphic elements IN PENCIL. Then, provide the mylar to the label makers in order to ensure accurate trimming. The mylar must be returned to Dusobox with the label shipment.

Mylars can be provided by our Design Department. We recommend obtaining a mylar before any film/ labels have been produced. We can not be held responsible for any labels trimmed improperly if our mylar and/or trim specs have not been used.



* We reserve the right to reject any supplied labels which do not conform to our guidelines.