

# Surface Mount DIP Tapped Passive Delay Line

The Surface Mount DIP Tapped Passive Delay Lines manufactured by Engineered Components Company are designed to provide precise and stable delays for analog delay line applications. These tapped delay lines are provided in a small 14-pin DIP package, available in impedances of 50, 100, and 200 ohms, with 10 equally spaced taps.

These delay lines are designed and tested in accordance with MIL-D-23859 and they are capable of meeting the environmental requirements of MIL-STD-202 for moisture resistance, vibration, temperature cycling, humidity, and life. The MTBF on these delay lines, when calculated per MIL-HDBK-217, for a 50 deg.C ground fixed environment and with 50VDC applied, is in excess of 12 million hours. The temperature coefficient of delay is less than 75 ppm/deg.C over the operating temperature range of -55 to +125 deg. C.

The delay line is fully encapsulated in epoxy resin and is housed in a Diallyl Phthalate case, green in color. The case marking is applied by silkscreen using white epoxy paint. The 13 beryllium copper leads are tin-lead plated and meet the solderability requirements of MIL-STD-202, Method 208.

Product Selection Table (Add G Suffix for Gull-Wing Leads, or J Suffix for J-Leads)

Part Number	Delay Time (nS)	Rise Time (nS)	* Tap Delay (nS)	Impedance (Ohms)	DCR (Ohms)
SMD-505	5.0+/-0.5	2.0	0.5+/-0.2	50	1.5
SMD-510	10.0+/-0.7	3.5	1.0+/-0.5	50	1.5
SMD-515	15.0+/-1.0	4.5	1.5+/-0.5	50	1.5
SMD-520	20.0+/-1.2	5.5	2.0+/-0.5	50	1.5
SMD-525	25.0+/-1.5	6.5	2.5+/-0.6	50	1.5
SMD-530	30.0+/-1.5	8.0	3.0+/-0.6	50	1.5
SMD-535	35.0+/-2.0	9.0	3.5+/-0.8	50	2.0
SMD-540	40.0+/-2.0	11.0	4.0+/-0.8	50	2.0
SMD-545	45.0+/-2.5	12.0	4.5+/-1.0	50	2.0
SMD-550	50.0+/-2.5	13.0	5.0+/-1.0	50	2.5
SMD-560	60.0+/-3.0	15.0	6.0+/-1.2	50	2.5
SMD-570	70.0+/-3.5	18.5	7.0+/-1.4	50	2.5
SMD-580	80.0+/-4.0	21.0	8.0+/-1.6	50	3.0
SMD-590	90.0+/-4.5	22.0	9.0+/-1.8	50	4.5
SMD-5100	100.0+/-5.0	22.0	10.0+/-2.0	50	5.0
SMD-5150	150.5+/-6.5	32.0	15.0+/-2.5	50	5.0
SMD-5200	200.0+/-10.0	40.0	20.0+/-3.0	50	6.0
SMD-1005	5.0+/-0.5	2.0	0.5+/-0.2	100	1.5
SMD-1010	10.0+/-0.7	3.5	1.0+/-0.5	100	1.5
SMD-1015	15.0+/-1.0	5.0	1.5+/-0.5	100	1.5
SMD-1020	20.0+/-1.2	5.0	2.0+/-0.5	100	1.5
SMD-1025	25.0+/-1.5	7.0	2.5+/-0.6	100	2.0
SMD-1030	30.0+/-1.5	8.0	3.0+/-0.6	100	2.0
SMD-1040	40.0+/-2.0	11.0	4.0+/-0.8	100	2.5
SMD-1050	50.0+/-2.5	12.5	5.0+/-1.0	100	2.5
SMD-1060	60.0+/-3.0	12.5	6.0+/-1.2	100	2.5
SMD-1070	70.0+/-3.5	18.5	7.0+/-1.4	100	2.5
SMD-1080	80.0+/-4.0	20.0	8.0+/-1.6	100	5.5
SMD-1090	90.0+/-4.5	22.0	9.0+/-1.8	100	5.5
SMD-10100	100.0+/-5.0	24.0	10.0+/-2.0	100	6.5
SMD-10150	150.0+/-6.5	32.0	15.0+/-2.5	100	6.5
SMD-2010	10.0+/-0.7	3.5	1.0+/-0.5	200	2.0
SMD-2020	20.0+/-1.2	6.0	2.0+/-0.6	200	2.0
SMD-2025	25.0+/-1.5	7.0	2.5+/-0.6	200	2.0
SMD-2030	30.0+/-1.5	8.0	3.0+/-0.6	200	2.0
SMD-2040	40.0+/-2.0	10.0	4.0+/-0.8	200	2.5
SMD-2050	50.0+/-2.5	12.0	5.0+/-1.0	200	2.5
SMD-2060	60.0+/-3.0	14.0	6.0+/-1.2	200	4.0
SMD-2080	80.0+/-4.0	19.0	8.0+/-1.6	200	5.0
SMD-20100	100.0+/-5.0	24.0	10.0+/-2.0	200	5.0

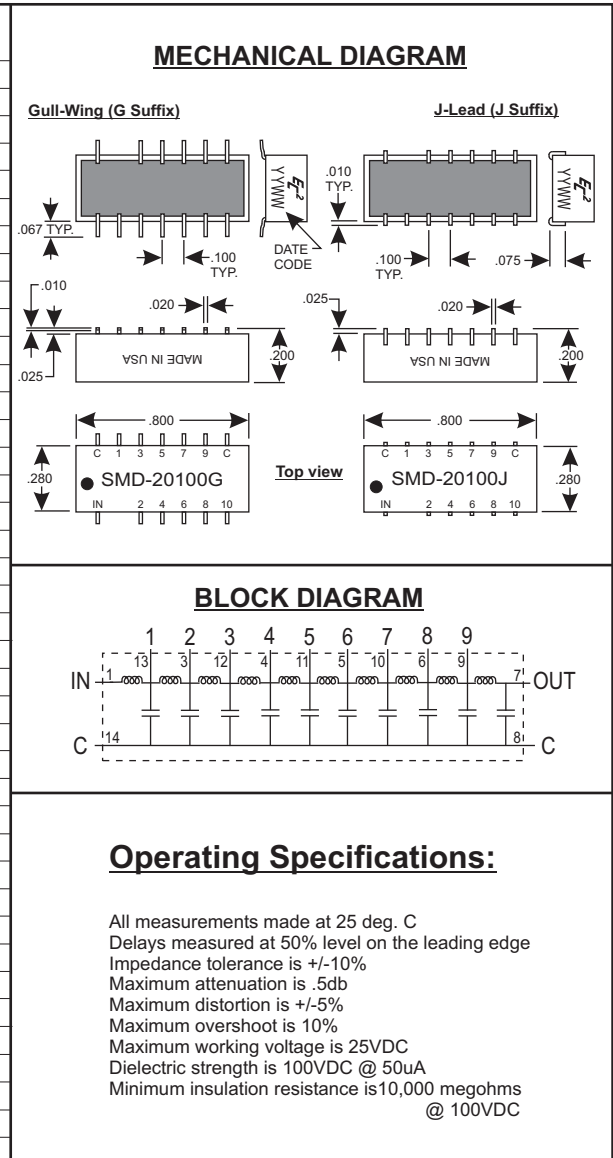

## Operating Specifications:

All measurements made at 25 deg. C  
 Delays measured at 50% level on the leading edge  
 Impedance tolerance is +/-10%  
 Maximum attenuation is .5db  
 Maximum distortion is +/-5%  
 Maximum overshoot is 10%  
 Maximum working voltage is 25VDC  
 Dielectric strength is 100VDC @ 50uA  
 Minimum insulation resistance is 10,000 megohms @ 100VDC

\*Referenced from the input of the delay line.

Special modules can often be manufactured to provide for customer specific applications.



**engineered components company**

A Division of Cornucopia Tool & Plastics, Inc. PO Box 1915, 448 Sherwood Rd., Paso Robles CA 93447

Phone: 805-369-0034

Fax: 805-369-0033

Web: www.ec2.com