

MINI-T STATIC PIPEBURSTER

SPECIFICATIONS & DATA SHEET

Machine passes through $\text{Ø}600 \text{ mm.}$ shaft-entry
($\text{Ø}23.6 \text{ inch.}$)

Mini-T machine diameter $\text{Ø}480 \text{ mm.}$
($\text{Ø}18.9 \text{ inch.}$)

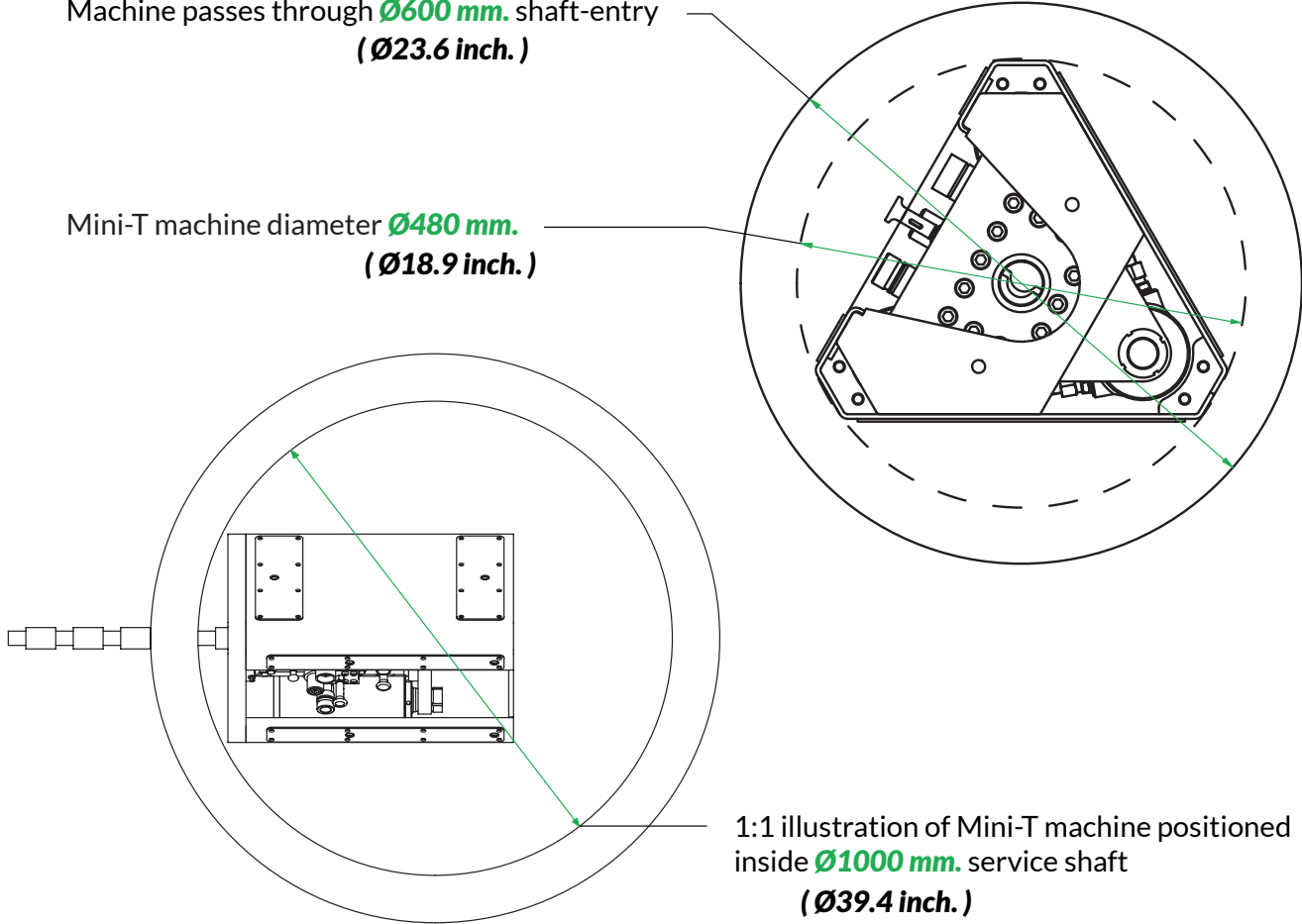

1:1 illustration of Mini-T machine positioned inside $\text{Ø}1000 \text{ mm.}$ service shaft
($\text{Ø}39.4 \text{ inch.}$)

Length and height of Mini-T unit inside service shaft (side view).
Steel-rod exit level from bottom of service shaft: 148 mm. (5.8 inch.)

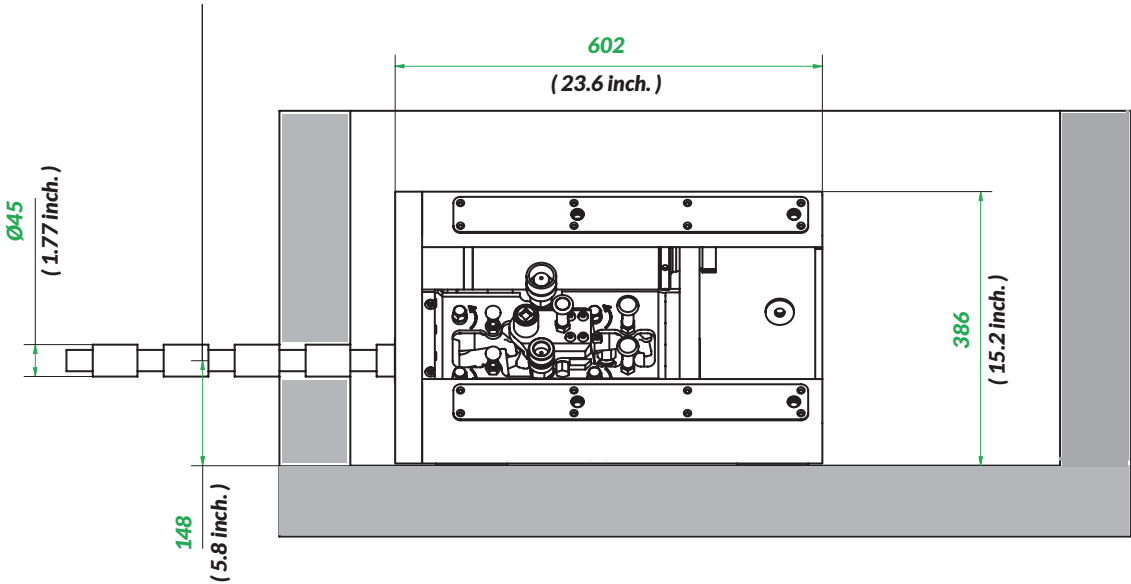



Mini-T

Hydro-static pipeburster with 37 metric tons of pulling power (81600 lbs.)

Hydraulic Power Pack

21 bhp. gasoline hydraulic Power Pack. Max. pressure 250 bar.

Specifications	Pulling unit	Power pack	Steel rods
Pulling force	37 metric tons (81600 lbs.)		
Measurements	60 x 44 x 48 cm. (23.6 x 17.3 x 18.9 inch.)	122 x 65 x 100 cm. (48.0 x 25.6 x 39.4 inch.)	Std. Ø45 mm. x 0.30 meter. (1.77 x 11.80 inch.) Option Ø30 mm. x 0.30 meter. (1.18 x 11.80 inch.)
Weight	158 kg. (348 lbs.)	250 kg. (550 lbs.)	Ø45 mm. steel rod: 2.90 kg. (6.4 lbs.) Ø30 mm. steel rod: 1.35 kg. (3.0 lbs.)
Engine		Vanguard Petrol air-cooled 22 bhp. / 16.40 kW. Electrical start, 4-stroke Fuel cap. 20 ltr. (4.4 gal.) Fuel consumption: 4 ltr. / hr. (0.9 gal. /hr.)	
Hydraulic system	3 cylinders	250 bar / 3625 psi. Variable pump flow: Pump cap: 18 ltr. / min. 2500 rpm. (3.95 gal. / min. / 2500 rpm.) Hydraulic oil cap. 60 ltr. (13.2 gal.)	
Operational speed	Up to 1.0 meter. / min. (3.3 ft. / min) Cylinder stroke: 10 cm. (3.9 inch.)		
Operational range, Existing pipe diameter	Ø40 mm. → Ø250 mm. (1.5 → 10.0 inch.)		