

15 Cylinder Pallet 6085

For trailers and trucks with a tomb style receiver

ProRack manufactures cylinder pallets for a wide variety of delivery trucks and trailers compatible with many tomb, picket and nesting systems found in the industry. ProRack's cradle and manifold expertise combined with steel product manufacturing volume result in high quality and competitive solutions for your cylinder distribution requirements.

Outstanding Cylinder Pallet Features

- Designed to handle up to 15 large high pressure cylinders.
- Built in locations for strap hooks
- Heavy duty construction with hot dipped galvanized finish for years of service life. Powder coating available.
- This pallet is commonly used with major gas producers fleet trucks. Custom pallets are available to fit your exact dimensions.

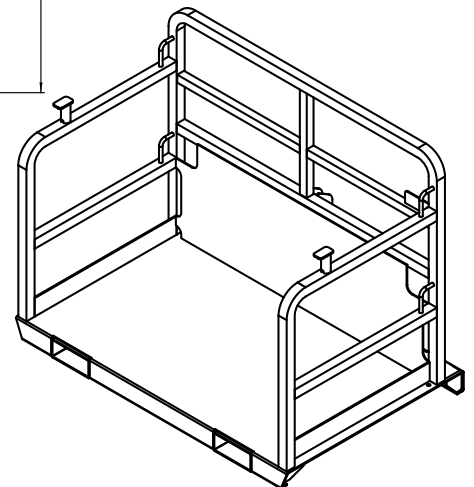
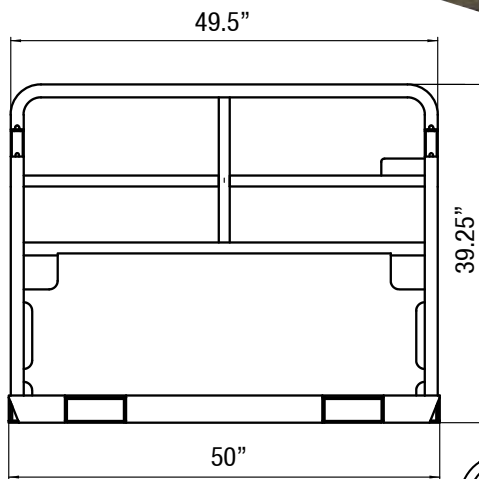
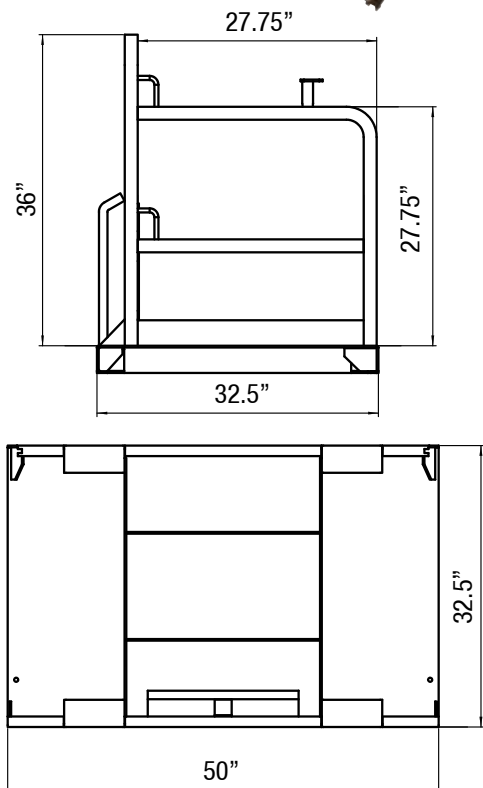

ProRack 15 Cylinder Pallet System		Ordering Chart				
Part Number	Description	Width	Depth	Height	Weight	
#		W	D	H	lbs	
P PALLET-6085-GA	ProRack 15 Cylinder Pallet with Tomb Receiver	50"	32.60"	39.25"	265 lbs	

* Ratchet straps sold separate.