

## FERRI A U

PROFILI NORMALI

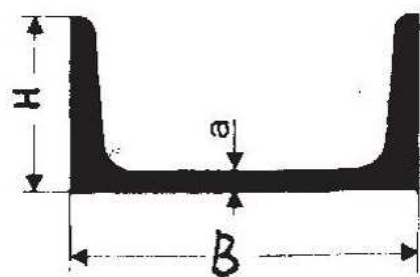

## FERRI A T

SPIGOLI TONDI

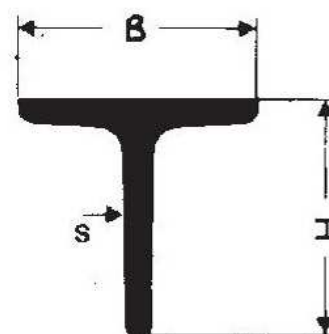

Dimens.		Spess. anima	Momento resist.	Peso a ml.
B	H			
30	33	5	4,3	4,27
40	35	5	7,1	4,87
50	38	5	10,5	5,59
65	42	5,5	17,7	7,09
80	45	6	25,5	8,64
100	50	6	41,1	10,60
120	55	7	50,7	13,35
140	60	7	86,4	16,01
160	65	7,5	115	18,84
180	70	8	150	21,98
200	75	8,5	191	25,28
220	80	9	245	29,36
240	85	9,5	300	33,21
260	90	10	371	37,92
280	95	10	448	41,84
300	100	10	535	46,16

L A T I		Sp. mm.	Peso a ml.
B	H		
45	45	5,3	3,37
50	50	6	4,44
60	60	7	6,28
70	70	8	8,32
80	80	9	10,70
90	90	10	13,40
100	100	11	16,40

SPIGOLI VIVI



L A T I		Sp. mm.	Peso a ml.
B	H		
15	15	3	0,32
20	20	4	1,13
25	25	4,5	1,61
30	30	5	2,16
30	30	5,5	2,35
35	35	5,5	2,79
35	35	6	3,01
40	40	6	3,48
40	40	6,5	3,75
45	45	6,5	4,26
45	45	7	4,56
50	50	7	5,11
60	60	7	6,21
60	60	8	7,03
70	70	9	9,26
80	80	10	11,75
90	90	10	13,03
100	100	11	16,30

## FERRI A U PROFILI SPECIALI

Dimens.		Spess. anima	Peso a ml.
B	H		
25	12	4	1,30
30	15	5	1,98
35	17	5,5	2,52
40	20	6	3,23
50	25	6	4,15
60	30	6,5	5,45