

Ted Synnott

Flora Bench

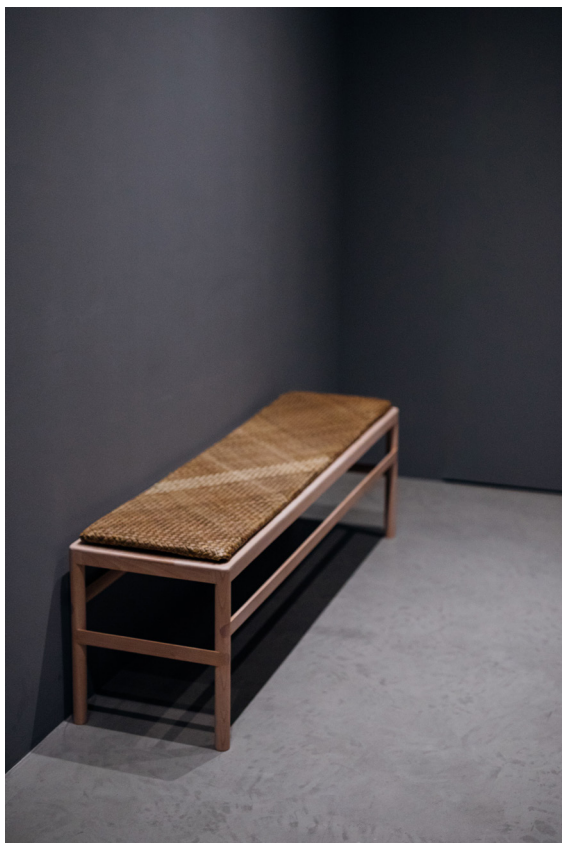

Flora Bench

Combining American Oak and Harakeke flax, the Flora Bench elevates the archetypal bench seat through hand finishing. The seat pad is hand woven in a traditional manner, while the frame joins curves and straight lines with detailed arcs.



Detail

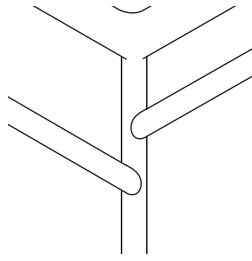

a. Straight lines become arcs
b. at intersections with legs.



b.

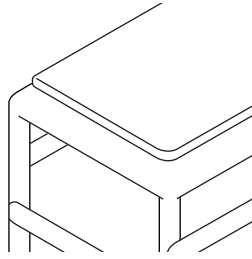

c. Harakeke flax woven
seat-pad.

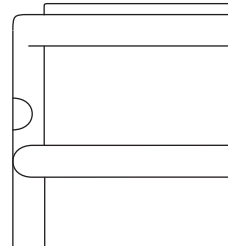

d. Outside edges run flush
with legs.

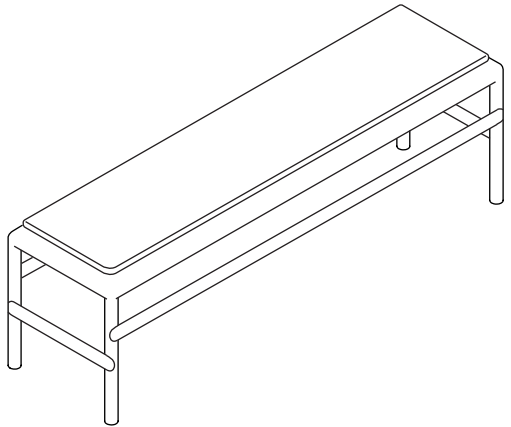

Material

American Oak

Finish

Natural Matte Lacquer

Dimensions

Standard

mm

Length

1550

Width

400

Height

450

Limited Due to the nature of Harakeke weaving, this piece is produced in limited quantities.



Harakeke

Flax was the most important fibre plant to Māori in New Zealand with each pā or marae cultivating a flax plantation, or a 'pā harakeke'. Depending on the purpose, varieties were grown with differing strength, colour and softness.

Flax leaves could be crafted into baskets, ropes, fishing lines, nets and clothing. It wove itself into the culture of Maori in New Zealand.

The seat-pad for the Flora Bench has been hand woven in Harakeke Flax. Each piece is unique in colour variation as a result.

