

WLKATA Mirobot

User Manual

Version: 1.1

Date: Mar 30th 2020



Beijing Tsineu Technologies Co., Ltd.
北京勤牛创智科技有限公司
www.wlkata.com

Copyright© Beijing Tsineu Technologies Co., Ltd. 2019. All rights reserved.

Without the written permission of the company, no unit or individual is allowed to extract or copy part or all of the contents of this document. And shall not be transmitted in any form.

Exemption from declaration

To the maximum extent permitted by law, the devices described in this manual (including its hardware, software, firmware, etc. Informal writing) are provided "by the status quo," and may have defects, errors or faults. Tsineu Technology does not provide any form of express or implied warranties, including but not limited to the warranties of merchantability, quality satisfaction, fitness for a specific purpose, noninfringement of the rights of third parties, etc. Informal writing ; nor Compensation for any special, incidental, incidental or indirect damages caused by the use of this manual or the use of our devices.

Before using this device, please read this user manual and relevant technical documents published on the Internet in detail and understand relevant information to ensure the manipulator is used on the premise of fully understanding the manipulator and its related knowledge. Tsineu Technology recommends that you use this manual under the guidance of professionals. All safety information contained in this manual shall not be regarded as the guarantee of Mirobot. Even if the manual and relevant instructions are followed, the hazards or losses caused in the use process may still occur.

It is the responsibility of the users of this device to ensure that the applicable laws and regulations of the relevant countries are followed and that there are no significant risks in the use of Tsineu Technology manipulator.

Beijing Tsineu Technology Co., Ltd

Address: Room 1603, Zhongguancun Energy & Security Science Park, Building 3,
Qinghua East Road 16, Haidian District, Beijing, China. 100083

Website: www.wlkata.com

Preface

Objective

This manual introduces the functions, technical specifications, installation instructions, system debugging, etc. Informal writing of the Mirobot manipulator, which is convenient users understand and use the Mirobot manipulator.

Readers

This manual applies to:

- ◆ Educational Engineer
- ◆ Sales Engineer
- ◆ Installation and commissioning engineer
- ◆ Technical support engineer

Revised records

Date	Version	Modification record
Dec 20th 2019	V1.0	The First-time Release
Mar 30th 2020	V1.1	Updates the teach pendant section Updates the trouble shooting section

Symbolic conventions

The following symbols may appear in this manual, and their meanings are as follows.



Symbol	Explain
 DANGER	Indicates a high potential hazard which, if not avoided, could result in personnel death or severe injury.
 WARNING	Indicates a moderate or low potential hazard, if not avoided, may cause slight personal injury, manipulator damage.
 NOTICE	This indicates that there is a potential risk, which may lead to arm damage, data loss ,or unpredictable results.
	Representation is the additional information of the text and the emphasis and supplement to the manual.

Table of Contents

1	Introduction of WLKATA Mirobot	7
1.1	Structure of WLKATA Mirobot.....	7
1.2	Items in the WLKATA Mirobot standard set.....	9
1.3	Add-ons and accessories.....	9
2	Safety precautions	10
2.1	General Safety.....	11
2.2	Precautions.....	12
3	Quick start	16
3.1	Power adapter and USB cable connection.....	16
3.2	Installing the driver and WLKATA Studio.....	17
3.2.1	System environment requirements.....	17
3.2.2	Downloading WLKATA Studio and the driver packages.....	17
3.2.3	Installing and verification the driver.....	17
3.2.4	Installing and verification of WLKATA Studio.....	19
3.3	Powering on and off WLKATA Mirobot.....	22
3.4	Start using the manipulator.....	22
3.4.1	Prerequisite.....	22
3.4.2	Preparing operation steps.....	23
3.4.3	Using the ROBOT JOINT MODE control function.....	25
3.4.4	Using the COORDINATE MODE control function.....	26
3.4.5	Using the TEACHING function.....	27
3.4.6	Using the BLOCKLY function.....	30
3.4.7	Using the gripper module.....	31
3.4.8	Using the DRAWING function.....	34
3.5	Using the teach pendant (Bluetooth controller).....	39
3.5.1	Product description.....	39

3.5.2	Product function and parameter description	39
3.5.3	Operation Guide	41
3.5.4	Cautions and Disclaimers.....	48
3.5.5	Disclaimers.....	49
4	Working principle and specification	50
4.1	Working space.....	50
4.1.1	Coordinate system	50
4.1.2	Sports function	52
4.2	Technical specifications.....	53
4.2.1	Technical parameters.....	53
4.2.2	Technical parameters.....	55
5	Interface description	55
5.1	Interface board of the manipulator	55
5.2	Interface board of the Extender Box.....	56
Appendix I	58
	WLKATA Mirobot Calibration Operation	58
Appendix II	60
	Trouble shooting list of WLKATA Studio and Mirobot.....	60

1 Introduction of WLKATA Mirobot

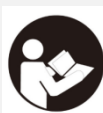
WLKATA Mirobot is a six-axis mini industrial robot arm manipulator and is independently developed and launched by Beijing Tsineew Technologies Co., Ltd. The WLKATA Mirobot manipulator is primarily developed for STEAM makers, and adolescent education and higher education purpose.

It represents a new generation of lightweight six-axis desktop robot arm model, which integrates a variety of practical functions, such as drawing, handling, stacking, painting, writing and machine vision. Users can easily control Mirobot by remote controller, graphical programming, teaching and play. It has a rich I / O extension interface, which allowed it to connect to diverse end-effectors. For advanced operation, users could adopt Python, C++ and more for subsequent development.

1.1 Structure of WLKATA Mirobot

WLKATA Mirobot is mainly composed by a base, six rotating joints, a lower arm, an upper arm, an end-effector connection plate., as is shown in Figure 1.1. There are a total of six robot joints in Mirobot, please see Figure 1.2 to familiar with the name of each of the six joints. The reference frame is shown in Figure 1.3. For more information of the structure of Mirobot, please refers to **4 Working principle and specification** in this manual.

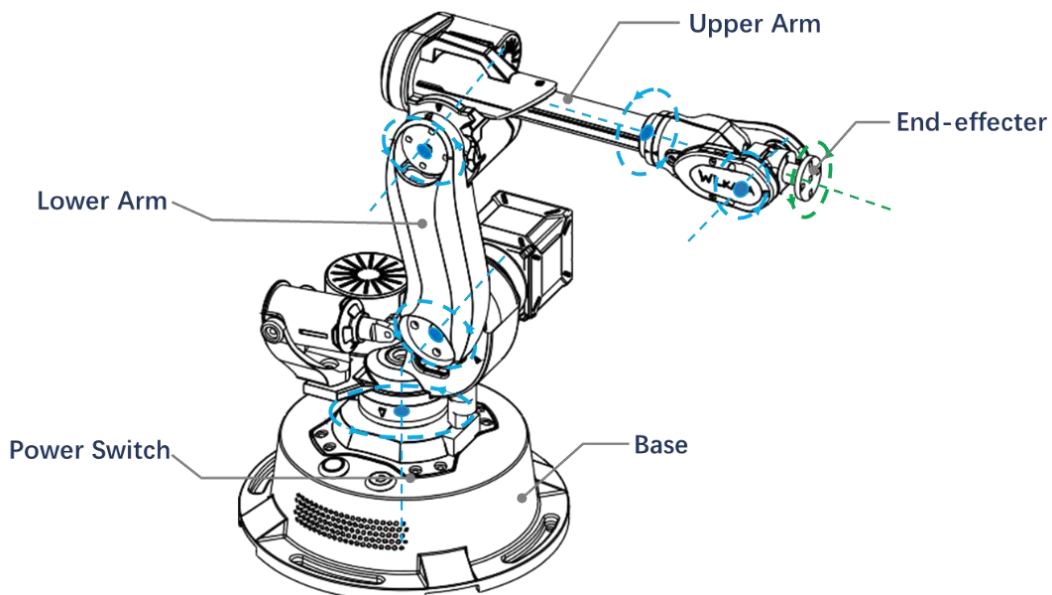

Figure 1.1 The Structure of WLKATA Mirobot

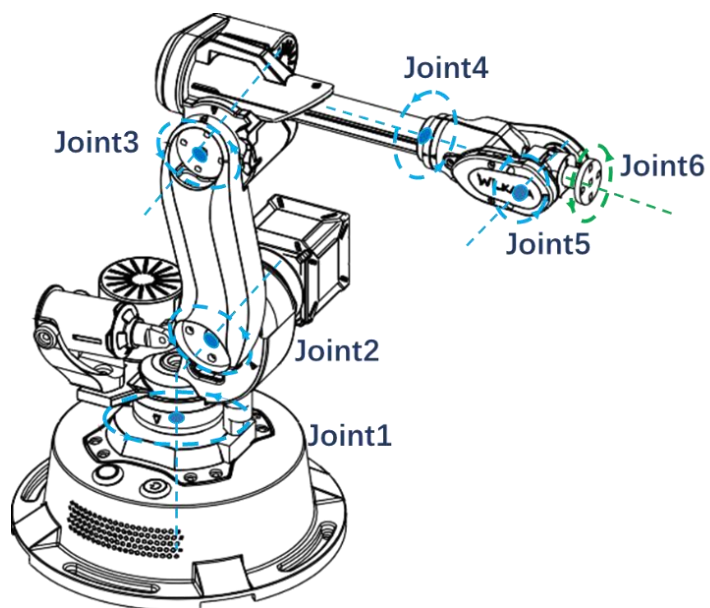

Figure 1.2 The Six Joint Frame Of WLKATA Mirobot

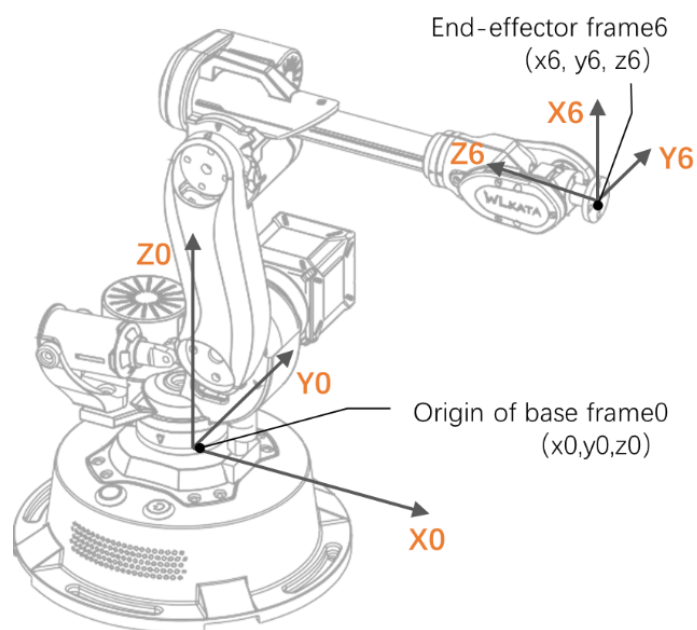

Figure 1.3 Reference Frame of WLKATA Mirobot

1.2 Items in the WLKATA Mirobot standard set

The WLKATA Mirobot standard set is ready for users who want to experience the essential functions of the Mirobot. There are 10 items in the standard set package, including the Mirobot manipulator, User Manual (paper-based simplified version), Bluetooth Box, Extender Box, IDC Cable, Gripper Module, Pen Holding, Power Supply, USB Cable and Hex Screwdrivers. As shown in Figure 1.4.

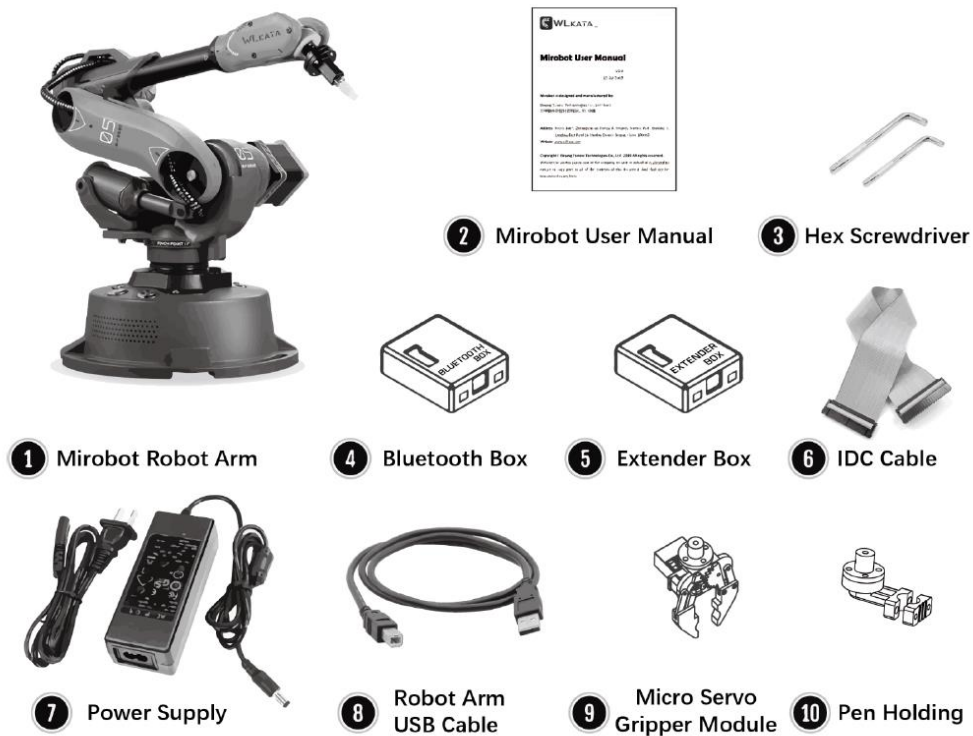



Figure 1.4 Items in the WLKATA Mirobot standard set

1.3 Add-ons and accessories

A rich range of add-ons are available for the WLKATA Mirobot. Please refer to the following table to check the name and function of the add-ons. As shown in Figure 1.5.

11	Robot Controller	
12	Robot Controller USB Cable	











13	Low Power Pneumatic Unit	
14	Suction Cup	
15	2-Finger Gripper	
16	High Power Pneumatic Unit	
17	Universal Ball Gripper	
18	GoPro (Hero7) Carrier	
19	Sliding Rail	
20	Conveyor Belt	
21	Robot Arm Vehicle	
22	Robot Arm Vehicle Power Supply and Battery	

Figure 1.5 Add-ons and accessories for the WLKATA Mirobot

2 Safety precautions

This chapter introduces the safety precautions when using this device. Please read this manual carefully before using the manipulator for the first time. This device should be used in an environment that meets the below requirements. Do not modify the device without authorization. Otherwise, it may cause device failure, even personal injury, electric shock, fire, etc. The installation, operation, teaching, programming, and system development personnel of the manipulator must first read the manual carefully and use the manipulator in strict accordance with the specifications of the manual.

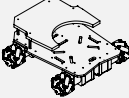
2.1 General Safety

DO NOT Change or Modify the Circuit or Wire.



The manipulator is an electrical equipment. Nonprofessionals are not allowed to change or modify the circuit or wire. Otherwise, it is easy to cause injury to the equipment or person.

When using the manipulator, the following safety rules shall be followed:

- ◆ The "DANGER," "WARNING," and "NOTICE" described in the manual are only used as supplementary instructions for all safety precautions.
- ◆ Please use the manipulator within the specified environment. If the manipulator is used beyond the specification and load conditions, the device lifetime will be shortened and even cause damages to the equipment.
- ◆ The personnel responsible for the installation, operation and maintenance of the WLKATA Mirobot manipulator must firstly receive training, and understand various safety precautions, and master the correct operation and maintenance methods before operating and maintaining the manipulator.
- ◆ It is not suggested to repair the faulty parts or dismantle the manipulator without professional training. If the devices fail, please contact the WLKATA Mirobot technical support engineer for advices.
- ◆ The high corrosive cleaning is not suitable for the cleaning of the manipulator, and the anodized parts are not suitable for immersion cleaning.
- ◆ If needs to discard the device, please correctly dispose it as industrial waste in accordance with relevant laws to protect the environment.
- ◆ There are small parts in the packing box. DO NOT let children play with the packing or parts in the box in order to prevent swallowing or hurts.
- ◆ If the manipulator is used by child, at least one adult must be on the side to monitor the child's operation.
- ◆ The equipment shall be shut down when the operation is completed.
- ◆ In the process of manipulator movement, please do not extend your hand into the movement range of the manipulator to avoid bumping or pinching.
- ◆ It is strictly prohibited to change or remove and modify the nameplate, description, icon, and mark of the manipulator and related equipment.

- ◆ During the handling and installation, please pay attention to handle with care according to the instructions. Otherwise, it is easy to damage the manipulator.
- ◆ When operating the manipulator, the local laws and regulations shall be strictly observed. The safety precautions described in the manual are only as a supplement to local safety regulations.
- ◆ Before operating the manipulator, please refer to this WLKATA Mirobot User Manual which is downloadable in the WLKATA official website.

2.2 Precautions

I. Lifting and Handling Mirobot Correctly



Always remember to lift and handling Mirobot by holding the Lower Arm with one hand and holding the Base with the other hand. One should not lift or handle Mirobot by holding the Upper Arm, or it would cause a damage to the motor gears of the major joints.

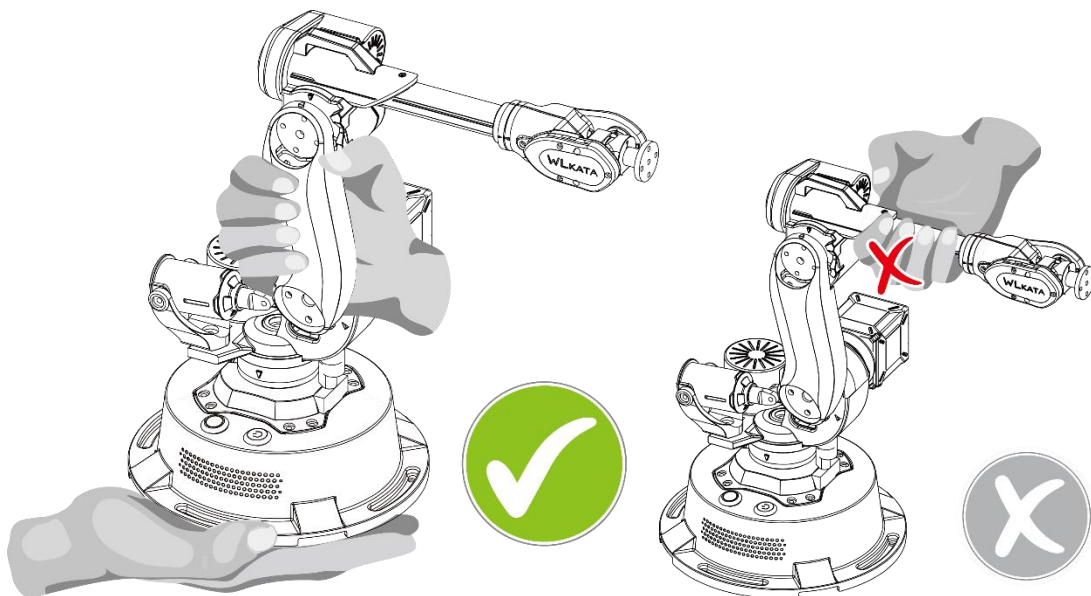

II. Be Careful of Your Finger and Preventing Pinching



When the manipulator is during operation, do not place your fingers in the gap between the upper and lower arms, or the cap between the lower arm and base to prevent pinching.

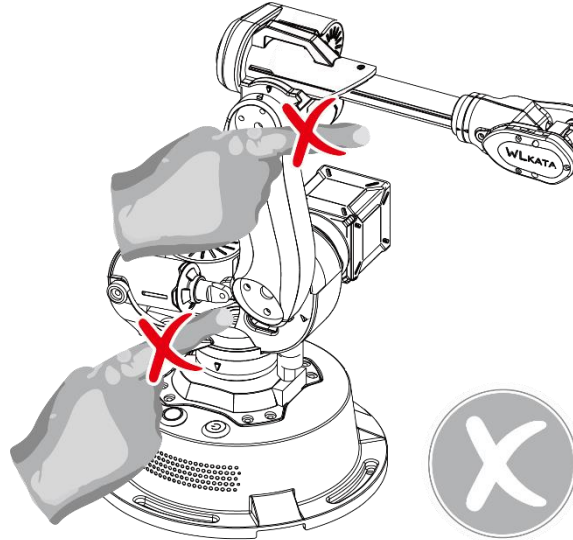

III. DO NOT Twisting the Joints by Hand!



DO NOT (!) twist the Joint 1 or Joint 3 by hand in any case, since this would lead to a fetal damage to these joints (due to the high reduction gear ratio of these motors). It is only allowed to adjust the joints by using WLKATA studio or proper operation software.

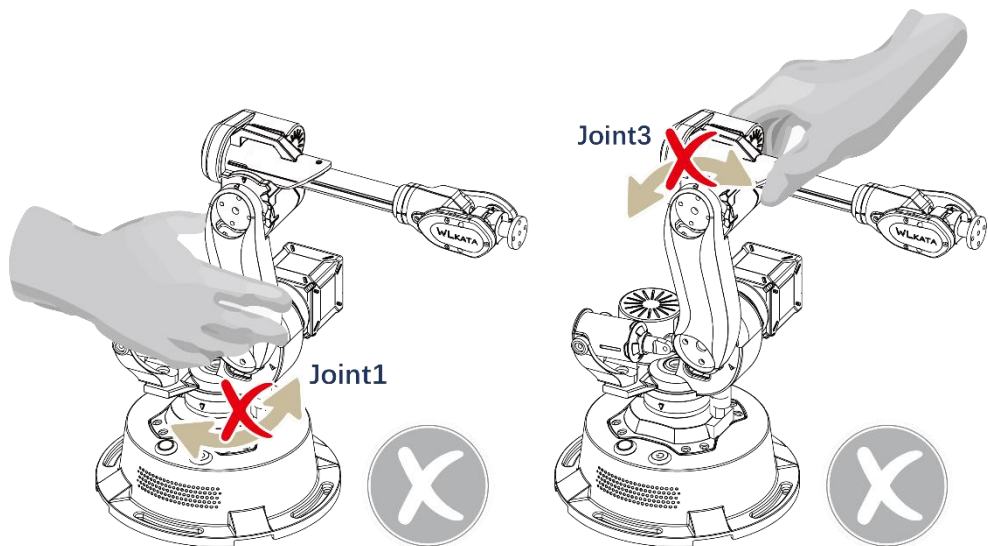

IV. Caution the Hot Surface of Motor & Chip



When Mirobot is powered on, DO NOT (!) touch the surface of joint 6 motor or the chip by hand, as those parts could be very hot during working.

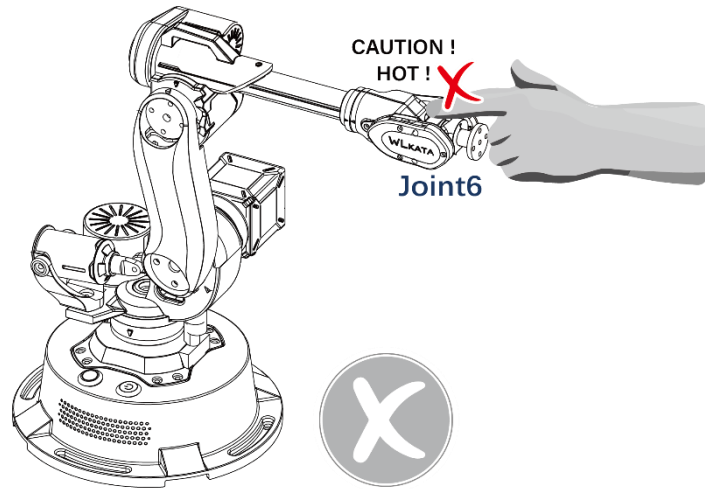

VI. Press the RESET Bottom for a Hardware Emergency Stop



In any case of illegal or abnormal operation of the Mirobot, one should press the RESET button immediately on the top of the Mirobot base for an emergency stop. Then before any further operation, remember to execute the **HOMING** action.



V. Execute HOMING action on Each Time Powering on or re-connect the Mirobot manipulator



Each Time the manipulator is powered on, RESET from an emergency stop, or reopen the WLKATA studio, the user must execute the HOMING action by click the **HOMING** button in WLKATA Studio to homing the joints position. One should wait for the HOMING action to be completed before any further operation. (Please refer to 3.4.2 for detailed instruction).

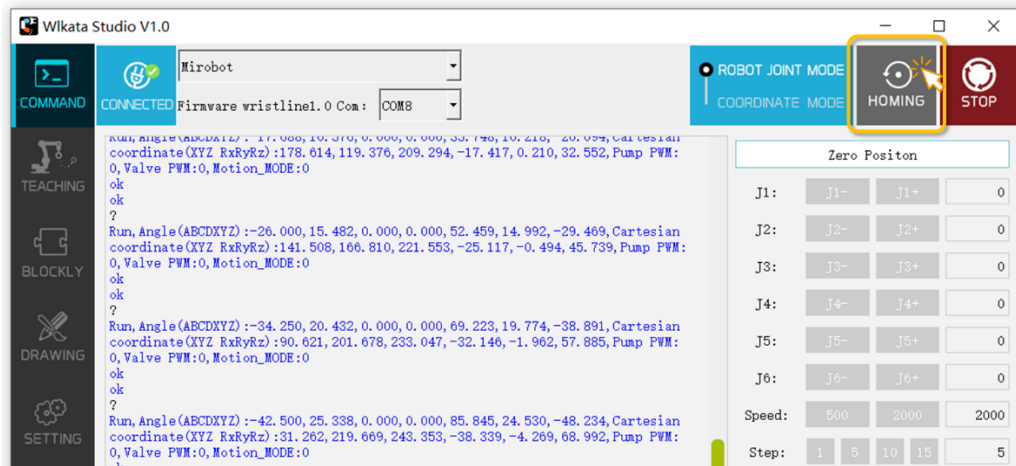

VII. Unplugging All External Components When Powered Off



When power off the manipulator, please disconnect and unplug all external components from the manipulator, such as Bluetooth box, extender box, color sensor, sliding rail, conveyor belt etc. Otherwise the manipulator and the external components may be damaged.

VIII. Avoid Using This Device for Laser Engraving



This manipulator is not designed for executing laser engraving. For users who use this device in potentially hazardous conditions, one should wear full personnel protection equipment, including glass, glove and use proper protection cover unit, etc.

3 Quick start

This chapter briefly introduces how to control the manipulator by using WLKATA Studio, so that users can quickly understand and use the manipulator. The overall process of operation is shown in Figure 3.1.

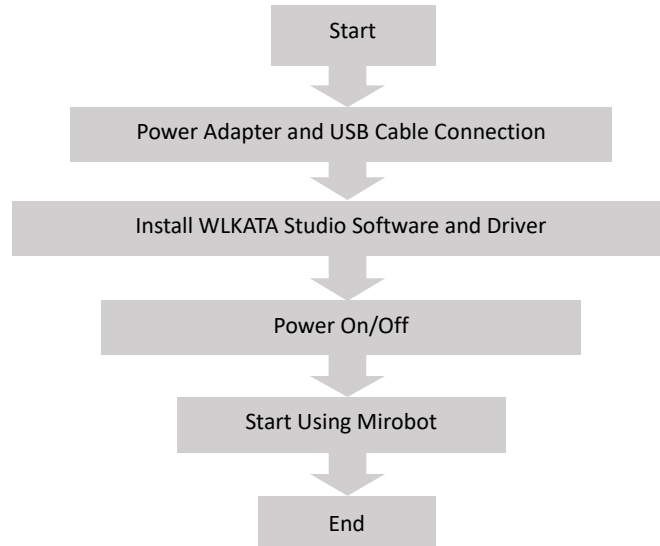

Figure 3.1 The quick start flow chart of using WLKATA Mirobot manipulator

3.1 Power adapter and USB cable connection

(1) Use the supplied USB data cable to connect the WLKATA Mirobot and your computer. As shown in the Figure 3.2



Figure 3.2 Connecting the manipulator to the computer

(2) Connect the supplied power adapter to the manipulator, as shown in Figure 3.3.



Figure 3.3 Connecting the manipulator to the power adapter

3.2 Installing the driver and WLKATA Studio

The users can control the Mirobot by using WLKATA Studio software to realize functions such as Joint Mode control, Coordinate Mode control, Teaching & Play, Blockly control and Drawing, etc.

3.2.1 System environment requirements

WLKATA Studio control software supports the following operating systems:

- Windows 7 (64 bit), Windows 8 (64 bit), Windows 10 (64 bit)

3.2.2 Downloading WLKATA Studio and the driver packages

Download WLKATA Studio software package and the CH340 driver package from <http://www.wlkata.com/site/download.html>.

3.2.3 Installing and verification the driver

1. Installing driver

Decompress the driver package, and click **SETUP.exe** in the directory to install the CH340 driver. In the pop-up window, click **INSTALL** and the interface shown in Figure 3.5 will pop up after successful installation. Click **OK**.

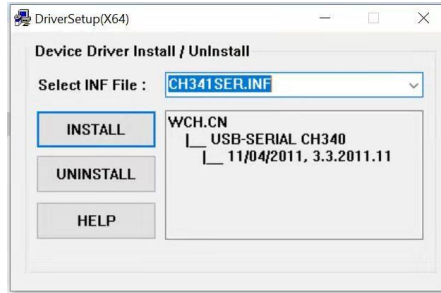

Figure 3.4 CH340 driver installation wizard interface

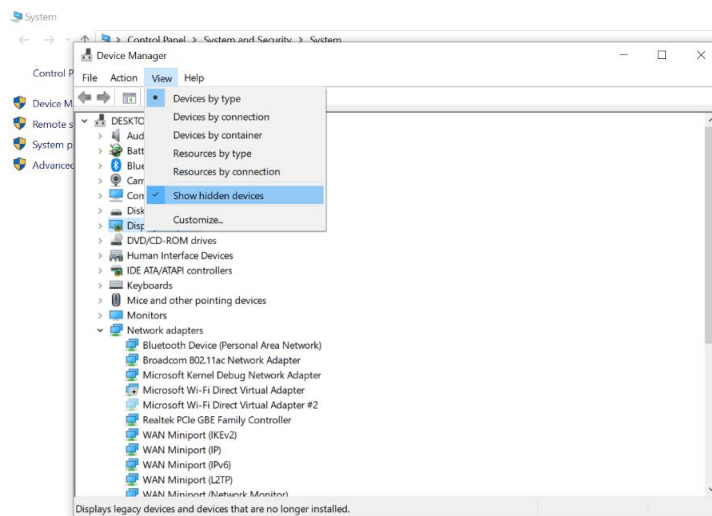

Figure 3.5 Driver installed successfully

2.Verifying the driver

(1) Ensure to connect the manipulator to the computer by using the supplied USB data cable.

(2) Open the **Device Manager** in your PC windows system. Ensure to tick the **Show hidden devices** option in the **View** menu. If the "**USB-serial ch340 (COM4)**" can be found in the **port (COM and LPT)**, it means the driver is installed successfully, as shown in Figure 3.6. The port number following the COM may be different depends on the default driver installation of your system.



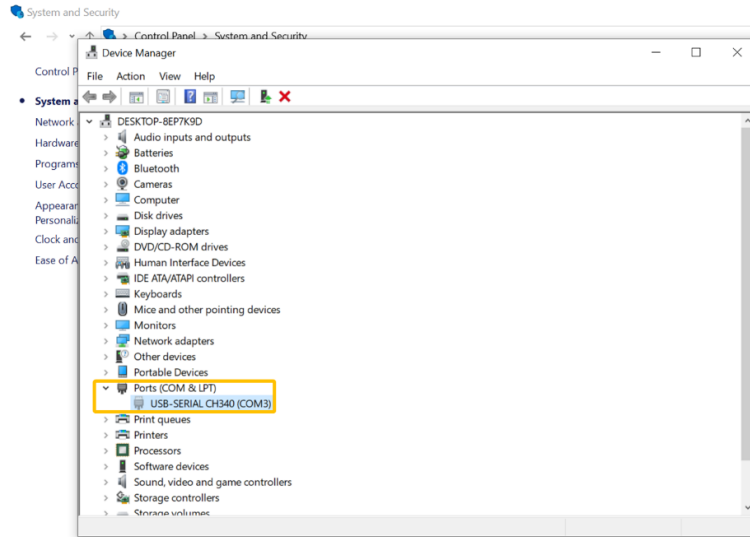

Figure 3.6 Serial port drive information of the WLKATA Mirobot manipulator

3.2.4 Installing and verification of WLKATA Studio

1. Installing WLKATA Studio

WLKATA Studio software package can be directly decompressed and used, as shown in Figure 3.7.

Decompress the WLKATA Studio software package to a **local root directory** such as D:\ or E:\ to avoid potential foreign language character disturb. Double-click **Wlkata Studio.exe** in the directory to open the software user interface. Figure 3.8

File Name	Created	Type	Size
Qt5Network.dll	2/8/2018 11:56 AM	Application extension	1,203 KB
Qt5Positioning.dll	2/9/2018 7:05 AM	Application extension	288 KB
Qt5PrintSupport.dll	2/8/2018 11:59 AM	Application extension	314 KB
Qt5Qml.dll	2/9/2018 6:28 AM	Application extension	3,430 KB
Qt5Quick.dll	2/9/2018 6:31 AM	Application extension	3,475 KB
Qt5QuickWidgets.dll	2/9/2018 6:33 AM	Application extension	72 KB
Qt5SerialPort.dll	2/9/2018 6:25 AM	Application extension	79 KB
Qt5Svg.dll	2/9/2018 6:12 AM	Application extension	321 KB
Qt5WebChannel.dll	2/9/2018 6:48 AM	Application extension	108 KB
Qt5WebEngineCore.dll	2/9/2018 12:30 PM	Application extension	69,068 KB
Qt5WebEngineWidgets.dll	2/9/2018 12:41 PM	Application extension	227 KB
Qt5Widgets.dll	2/8/2018 11:59 AM	Application extension	5,346 KB
QtWebEngineProcess	2/9/2018 12:39 PM	Application	17 KB
tmp_save_svg_qncz.gcode	1/17/2020 3:23 PM	GCODE File	24 KB
tmp_save_svg_qncz	1/17/2020 3:23 PM	SVG Document	2 KB
tmpmxf.py	1/17/2020 4:35 PM	PY File	1 KB
vcruntime140.dll	1/17/2020 3:20 PM	Application extension	86 KB
Wlkata Studio	1/12/2020 11:24 AM	Application	960 KB

Figure 3.7 Opening Wlkata Studio.exe in the local directory

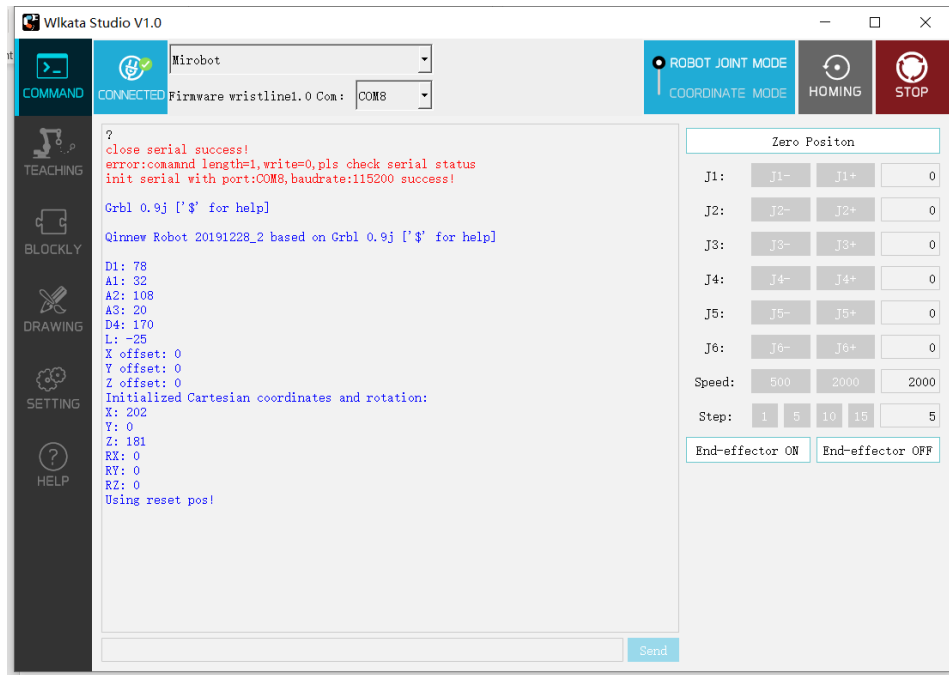

Figure 3.8 WLKATA Studio interface

2.Verifying WLKATA Studio Software

In the decompressed package, double-click to open the **Wlkata studio.exe**. If the Wlkata Studio software can be opened correctly, it means that the WLKATA Studio software is running successfully.

3.Verifying the device connection

(1) Open the **Wlkata Studio.exe**. The software should automatically search and connect to the manipulator after a few seconds. When successfully connects to the manipulator, the upper left corner of the WLKATA Studio interface should display the **CONNECTED** blue icon, as shown in Figure 3.9.

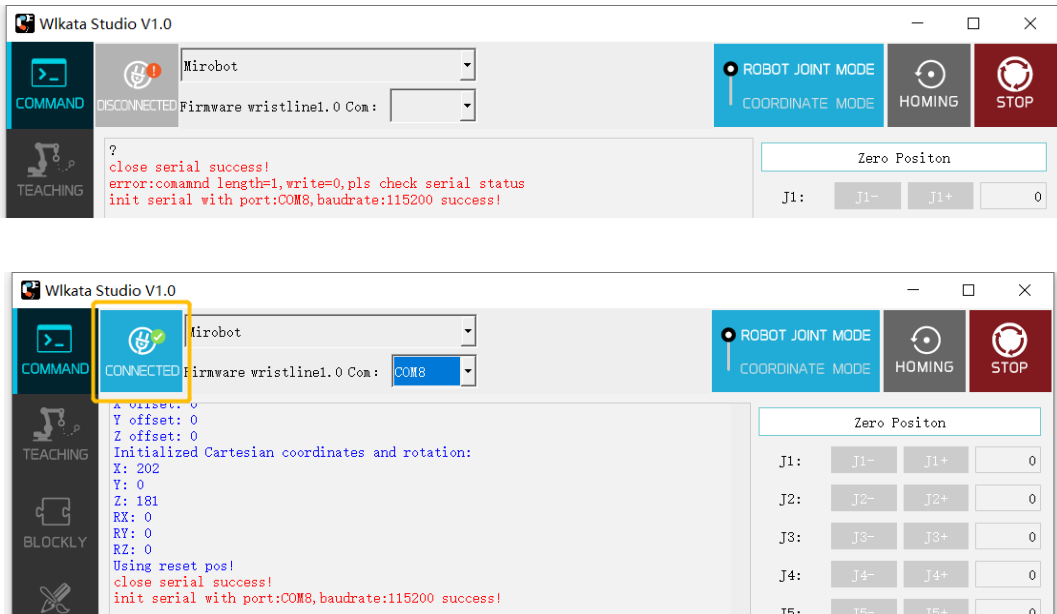

Figure 3.9 WLKATA Studio can search and connect to the manipulator automatically

(2) If the software did not connect to the manipulator automatically, please manually connect the manipulator by choosing the correct serial port COM_ number (as found in the step (2) in the content of 2.Verifying the driver) in the upper second drop-down list, as shown in Figure 3.10.

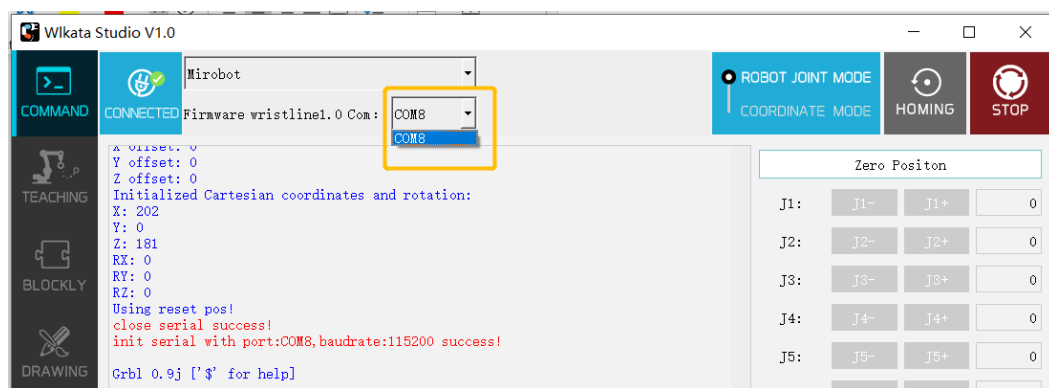

Figure 3.10 Manually setting a serial port number in the upper second drop-down list if the manipulator is not connected automatically

3.3 Powering on and off WLKATA Mirobot



DO NOT Twisting the Joint 1 or Joint 3 by Hand No Matter the Manipulator Is Powered On or Off!

Since this would lead to a fetal damage to the gears of these joints. (See the 2.2 Precautions in this manual)

Power on:

Ensure to connect the manipulator with supplied power adapter. Press the **ON/OFF** power button on the top of the manipulator base to power on the device. The green power indicator on the ON/OFF button will light up, as shown in Figure 3.11.



Figure 3.11 Switching on the manipulator

Power off:

Press the power button on the top of the base of the manipulator again to switch off the power. The power indicator light on the button will turned off.

3.4 Start using the manipulator

This chapter describes the essential control operation of this manipulator by using the WLKATA Studio software.

3.4.1 Prerequisite

- The driver and WLKATA Studio software have been installed successfully. For details, please refer to the 3.2 Installing the driver and WLKATA Studio software.
- The manipulator has been correctly connected to the computer, and the power supply

of the manipulator has been turned on. Please refer to 3.3 Powering on and off WLKATA Mirobot for detailed operation.

3.4.2 Preparing operation steps

1. Connecting WLKATA studio with the manipulator

Double click the **Wlkata Studio.exe** in the directory, and the Mirobot Studio interface should pop up. Then please follow the steps of 3.2.4 to verify the driver and connection. When the connection is succeeded, the CONNECTED blue icon should be displayed in the upper left corner of the WLKATA Studio interface.

2. HOMING the manipulator before any operation

Before any operation, the manipulator must be homed to the pre-designed homing position. Click the **HOMING** button in the WLKATA Studio, as shown in Figure 3.12. Wait for the manipulator to be homed. Figure 3.13 shows the manipulator during the homing process, and figure 3.14 shows the correct position of the manipulator after a successful HOMING action.

* Note: If the HOMING action is failed or interrupted, please reapply the power of manipulator and repeat the HOMING action again.



The manipulator must be HOMING again on each time reapplying power from a power failure or an emergency stop, or re-opened the WLKATA Studio. One should wait for the HOMING action to be fully completed before any further operation.

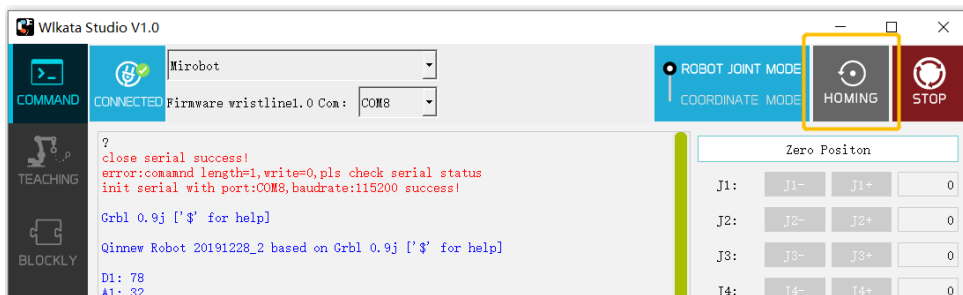

Figure 3.12 Doing the HOMING action each time powering on the manipulator



Figure 3.13 In the progress of HOMING the manipulator



Figure 3.14 The correct manipulator position after a successful HOMING action

3. Software emergency stop and reset

In case of any illegal operation of the manipulator, click the **STOP** button immediately in the Mirobot Studio to trigger a software emergency stop operation, as shown in the Figure 3.15.

After the emergency stop operation, press the **RESET** button on the top of the manipulator base to recover the device from the emergency status, as shown in Figure 3.16.

After press the RESET button, please **HOMING** the manipulator in the software again before continuing using the manipulator.



After a software emergency stop, press RESET on top of the base, and do the HOMING again before continuing using the manipulator.

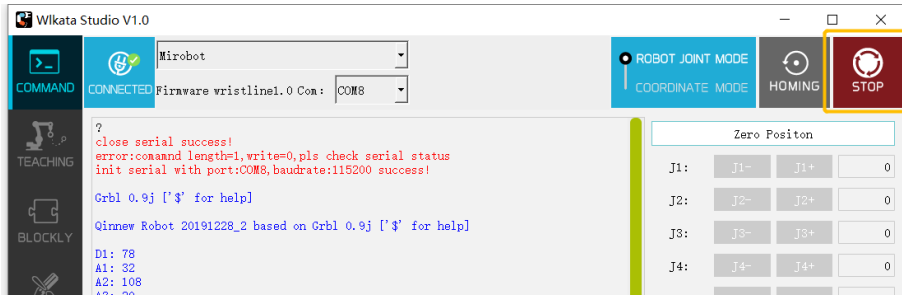

Figure 3.15 Emergency stop button in the WLKATA Studio



Figure 3.16 Pressing RESET button on the base of the manipulator after a software emergency stop

3.4.3 Using the ROBOT JOINT MODE control function

- (1) Click the COMMAND tab in the software interface, as shown in Figure 3.17.

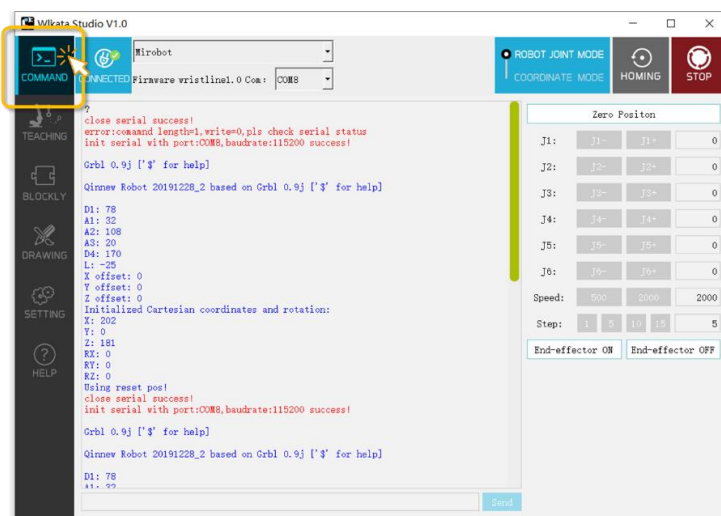

Figure 3.17 COMMAND tab in the WLKATA Studio software

(2) Switch to the ROBOT JOINT MODE in the upper-right control modes selection panel, as shown in Figure 3.18.

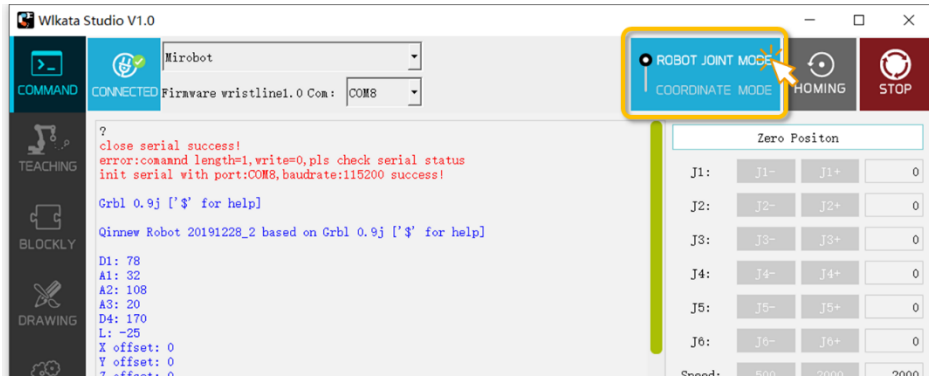

Figure 3.18 Selecting the ROBOT JOINT MODE

(3) Click each of the J+ J- control buttons on the right panel to control the motion of each of the six joints of the manipulator separately. The speed can be adjusted by input **Speed** value, and the step can be adjusted by input **Step** value. As shown in Figure 3.19.

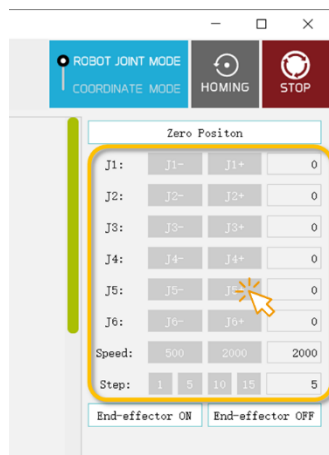

Figure 3.19 The ROBOT JOINT MODE control buttons

3.4.4 Using the COORDINATE MODE control function

(1) Click the COMMAND tab, as shown in Figure 3.17.

(2) Switch to COORDINATE MODE in the control modes selection panel, as shown in Figure 3.20.

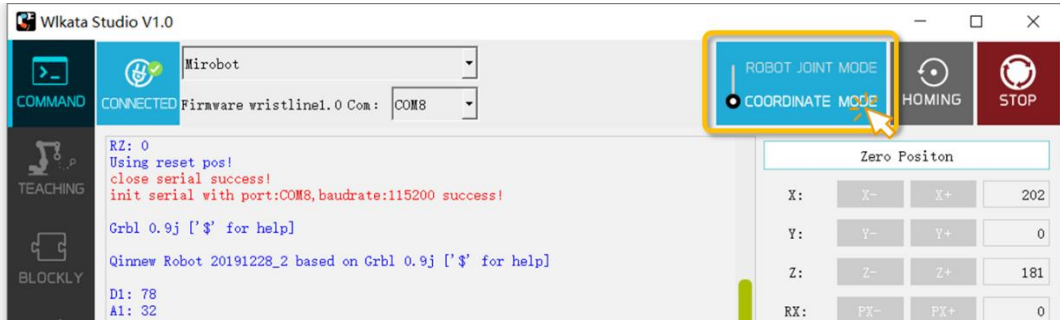

Figure 3.20 Selecting the COORDINATE MODE

(3) Click each of the control button on the right panel of the WLKATA Studio to control the spatial position and attitude (XYZ coordinate and RPY angle) of the End-effector of the manipulator. The speed can be adjusted by input **Speed** value, and the step can be adjusted by input **Step** value. As shown in Figure 3.21.

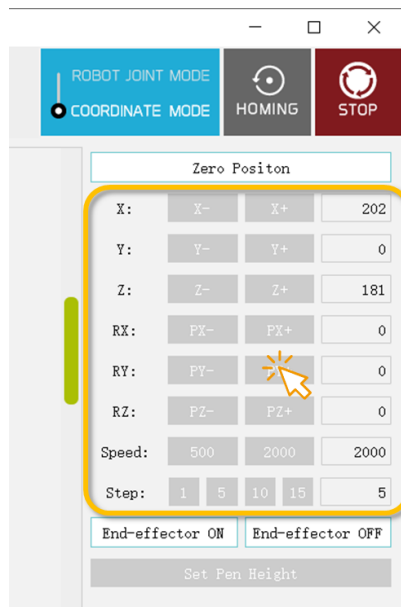

Figure 3.21 The COORDINATE MODE control buttons

3.4.5 Using the TEACHING function

(1) Click the TEACHING tab in the software to switch to the Teaching & Play page, as shown in Figure 3.22.

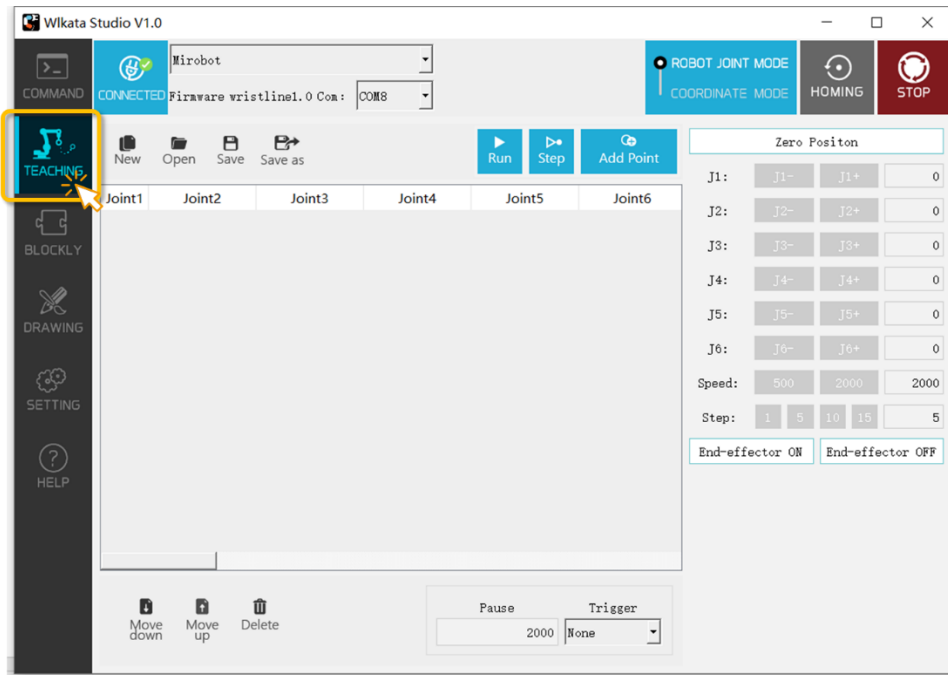

Figure 3.22 The TEACHING page in the WLKATA Studio software

(2) Choose one control modes (ROBOT JOINT MODE or COORDINATE MODE) in the control modes selection panel.



DO NOT Change the control mode during the same **TEACHING & PLAY** file/task, or the point data after switching the mode would be discordant and cause illegal motions.

(3) Click the - + control buttons on the right panel of WLKATA Studio to move the joints (under the ROBOT JOINT MODE) / or the position and attitude of the End-effector (under the COORDINATE MODE) to the wanted position. When adjusted to a satisfactory position point, click the **Add Point** button to add a teaching point, as shown in Figure 3.23.

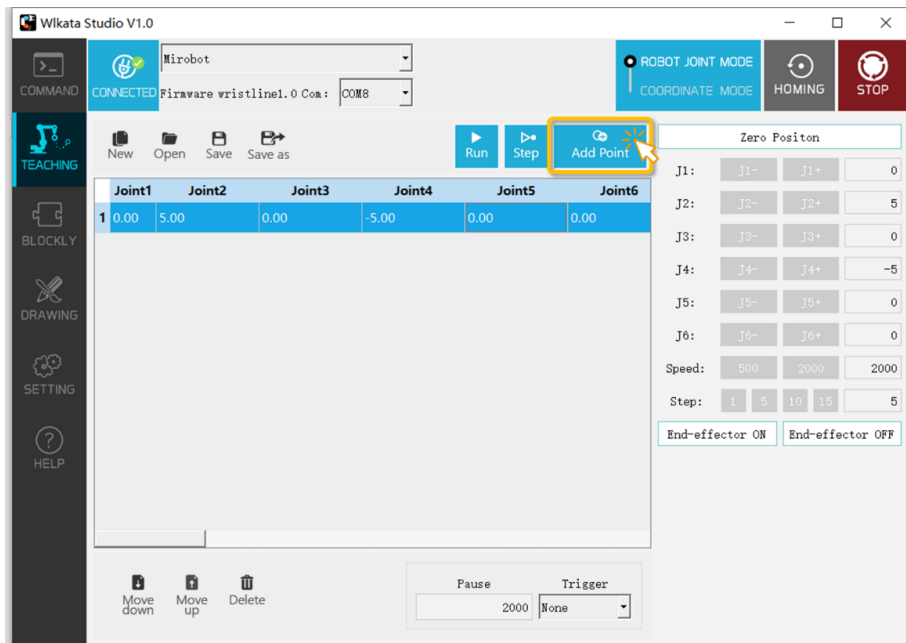

Figure 3.23 Adding the teaching points under the TEACHING page

(4) After adding the first teaching point, one could continue to adjust the position and posture of the manipulator, and then click the **Add Point** button to add the second and the third teaching point... until all teaching points are added.

(5) Edit the property of teaching points:

- Editing the teaching point in-line: single left-click on the top of the cell you want to edit --> input the desired value --> single left-click in blank space / or press Enter to confirm your edit. As shown in Figure 3.24
- Editing the teaching point by the right panel: single right-click on the top of the line you want to edit --> choose **Edit** in the pop-up manu --> adjust the value in the right panel -> move the mouse arrow back to the teaching point line you want to edit and single right-click on the top of the line again --> choose **Update** in the pop-up manu to apply the value on the right panel to the selected teaching point line. As shown in Figure 3.25

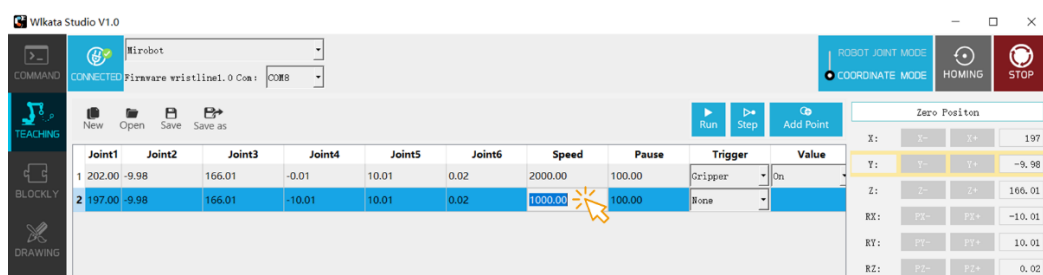

Figure 3.24 Editing the teaching point in-line

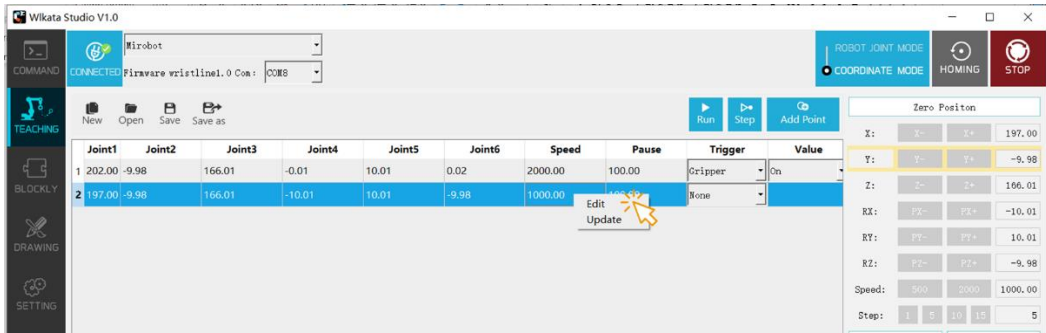

Figure 3.25 Editing the teaching point by the right-side panel

(6) To start a new task, click **New** to clear the current task and start again. To save the current Teaching & Play task, click **Save** and save the task in chosen directory. To open a Teaching & Play file created by WLKATA Studio earlier, click **Open** to lookup the file.

(7) Click **Move down** and **Move up** buttons to change the order of a teaching point line. Click **Delete** button to delete a teaching point line.

(7) Click **Run** button in the panel to realize the whole recurrence of the recorded teaching points in the list. Click the **Step** button in the panel to realize the single-step movement of the recorded teaching point one-by-one in the list. As shown in Figure 3.26.

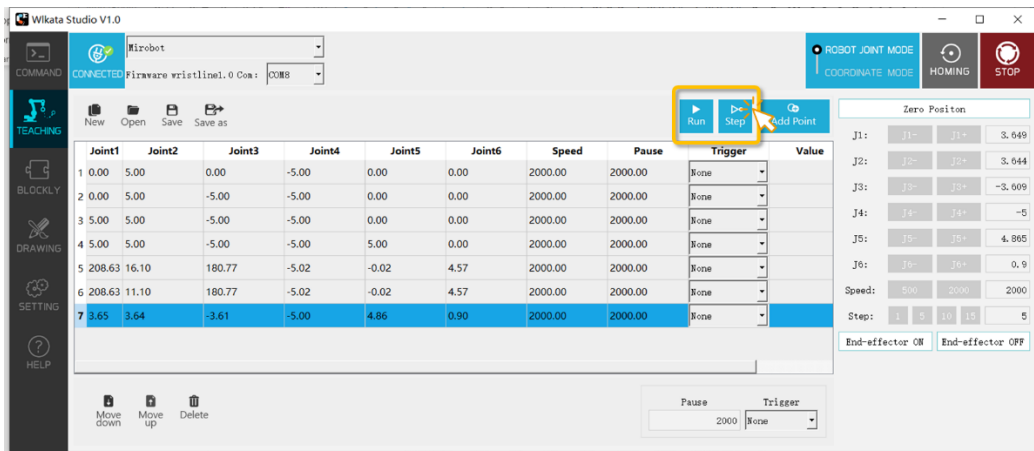

Figure 3.26 The continuous run and single-step run of teaching points in the TEACHING page

3.4.6 Using the BLOCKLY function

Blockly is an open-source graphical programming platform created by Google, which is easily to be learnt and applied by starters.

(1) Click the **BLOCKLY** tab in the software interface to switch to Blockly page.

(2) Drag and drop the Blockly module from the Selection Panel 1 to the Programming Panel 2 to program. The Code Panel 3 would show the python codes of the Blockly module on the Programming Panel, as shown in Figure 3.27.

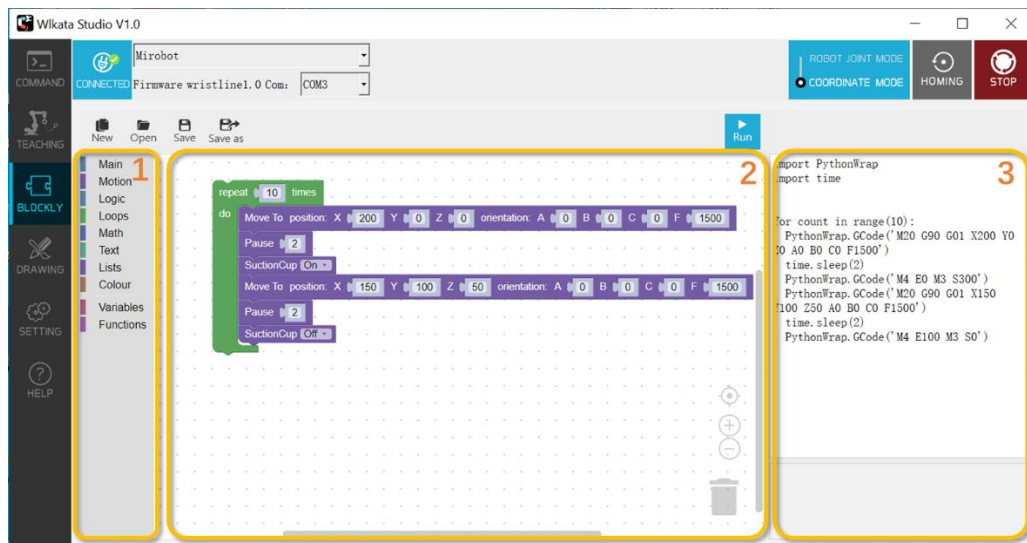

Figure 3.27 The Blockly graphic programming

(3) To start a new task, click **New** to clear the current task and start again. To save the current Blockly task, click **Save** and save the task in chosen directory. To open a Blockly file created by WLKATA Studio earlier, click **Open** to lookup the file. To delete a module, select the module and click the **Trash** icon.

(4) Click **Run** and the manipulator will move according to the program.

3.4.7 Using the gripper module

The gripper module is an end-effector designed for WLKATA Mirobot. Please follow the instruction in below to install and use the gripper correctly.



Power off the manipulator before installing the gripper module, or it could cause damage to the circuits of gripper or Extender Box.

(1) **Power off** the manipulator.

(2) Install the gripper module by screwing it on the end-effector with supplied hex screwdriver, as shown in Figure 3.28.

(3) Before plug the gripper wire connector into the Extender Box unit, trim off the fix protrusions on the wire connector to allow re-plug-in, as shown in Figure 3.29. Otherwise, the wire connector will be hardly unplugged from the socket.

(4) Plug the gripper wire connector into the **upper-second socket position** on the **Extender Box** unit, as shown in Figure 3.30.

(5) Link the Extender Box with the Mirobot by using the supplied **IDC cable**, as shown in Figure 3.30.



Figure 3.28 Installing the gripper module by a hex screwdriver

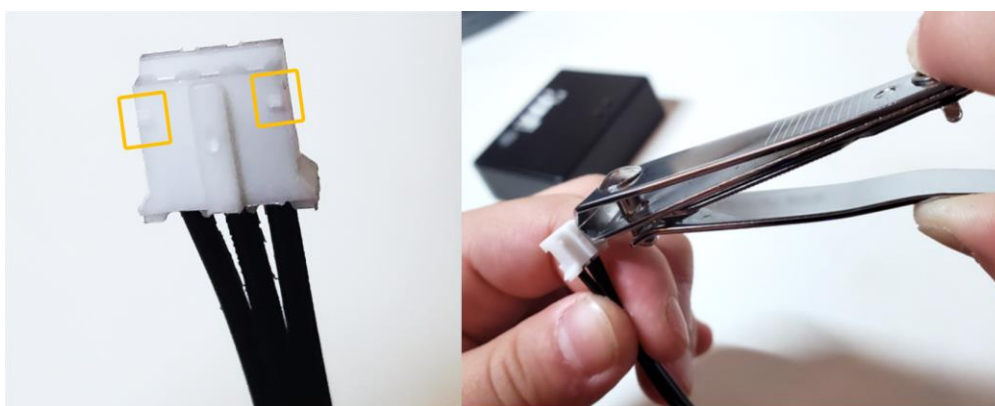

Figure 3.29 Trimming off the fix protrusions on the wire connector to allow re-plug-in

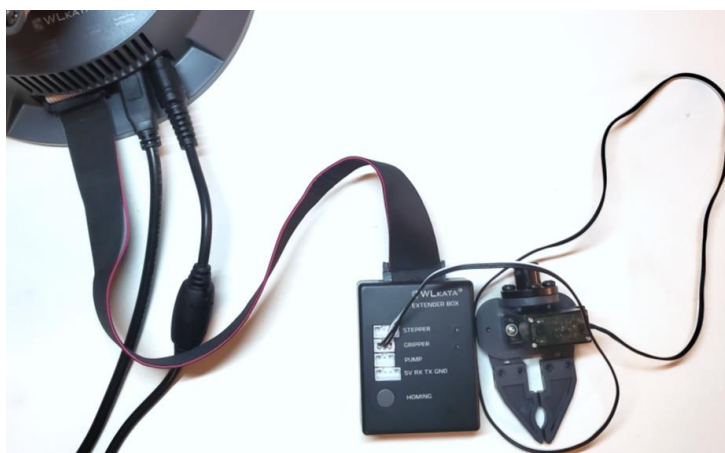

Figure 3.30 The method of connecting the gripper with the manipulator

(4) **Control the gripper status (open and close):** The gripper can be controlled under the COMMAND, TEACHING and BLOCKLY functions in the WLKATA Studio:

- In the COMMAND page, control the gripper by click the **End-effect on** and **End-effector off** buttons on the right panel. Figure 3.31
- In the TEACHING page, control the gripper by editing the **Trigger** cell and **Value** cell of the teaching point line. Figure 3.32
- In the BLOCKLY page, control the gripper by drag and edit the **Gripper module** which can be found in the **Motion** panel. Figure 3.33

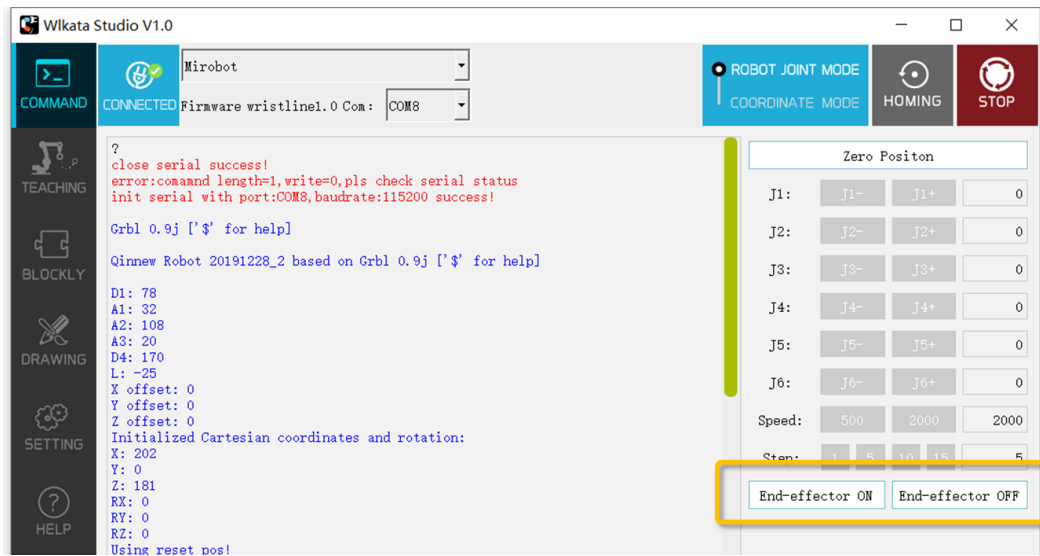

Figure 3.31 Controlling the gripper in the COMMAND function

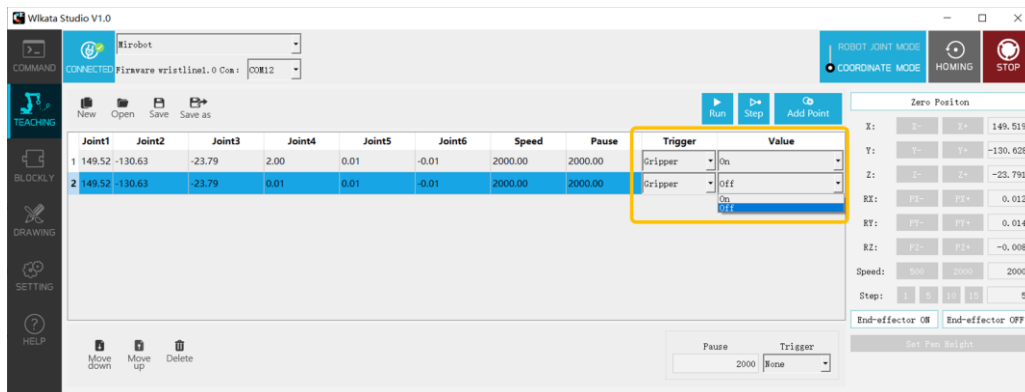

Figure 3.32 Controlling the gripper in the TEACHING function

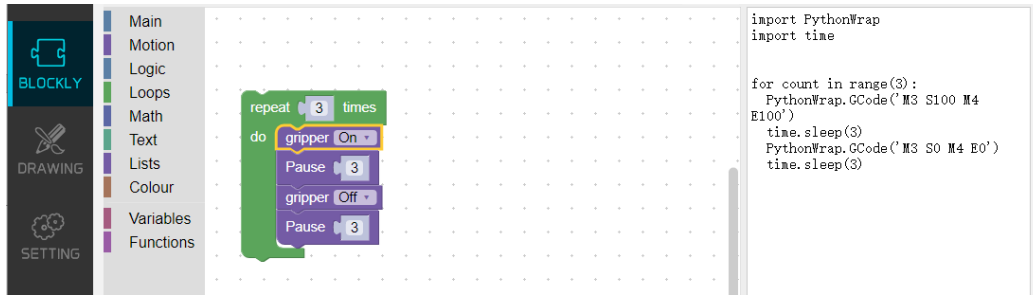

Figure 3.33 Controlling the gripper in the BLOCKLY function

(5) When finish using the gripper, **power off** the manipulator, and **unplug** the **IDC cable** from the back of manipulator.

3.4.8 Using the DRAWING function

Helping Us to Make the Drawing Function Better



The Drawing function of WLKATA Mirobot is still in development. Users may encounter inconvenience during operation. Please provide us your valuable feedback in the Facebook WLKATA fans club or in our website forum. Your supports and our efforts would make the WLKATA Studio better soon.

Preparation before drawing

- (1) Install the pen-holder module and the pen, as shown in Figure 3.34.
- (2) Prepare a **thin soft cushion** and place it under the paper to provide additional buffering during drawing. Figure 3.35



Figure 3.34 Installing the pen-holder module and the pen



Figure 3.35 Placing a thin soft cushion under the paper to provide buffering during drawing

(2) We need to **set the height of the pen first** before drawing. Please follow the below instruction:

- In the WLKATA Studio software, click the **COMMAND** tab in the software interface to switch to the Command page.
- Choose the **COORDINATE MODE** in the control modes selection panel. So that the **Set Pen Height** button is shown in the lower position of right panel.
- Make the manipulator back to the homing position by click **Zero Position** button on the right panel, or click **HOMING**.
- After the manipulator back to the homing position, click the **Z-** button to adjust the height of the pen tip until it just touches the paper, as shown in Figure 3.36.
- The value of **Z** axis shall **between around -20 and 20**. **Be careful not to over-adjust the Z axis position lower than it need to be**, or the pen tip would hit the desktop too hard, interrupt the pen from moving and even cause damages to the joints.
- When the pen tip is just touches the paper, click **Set Pen Height** button to set this pen height for the DRAWING function, as shown in Figure 3.36.

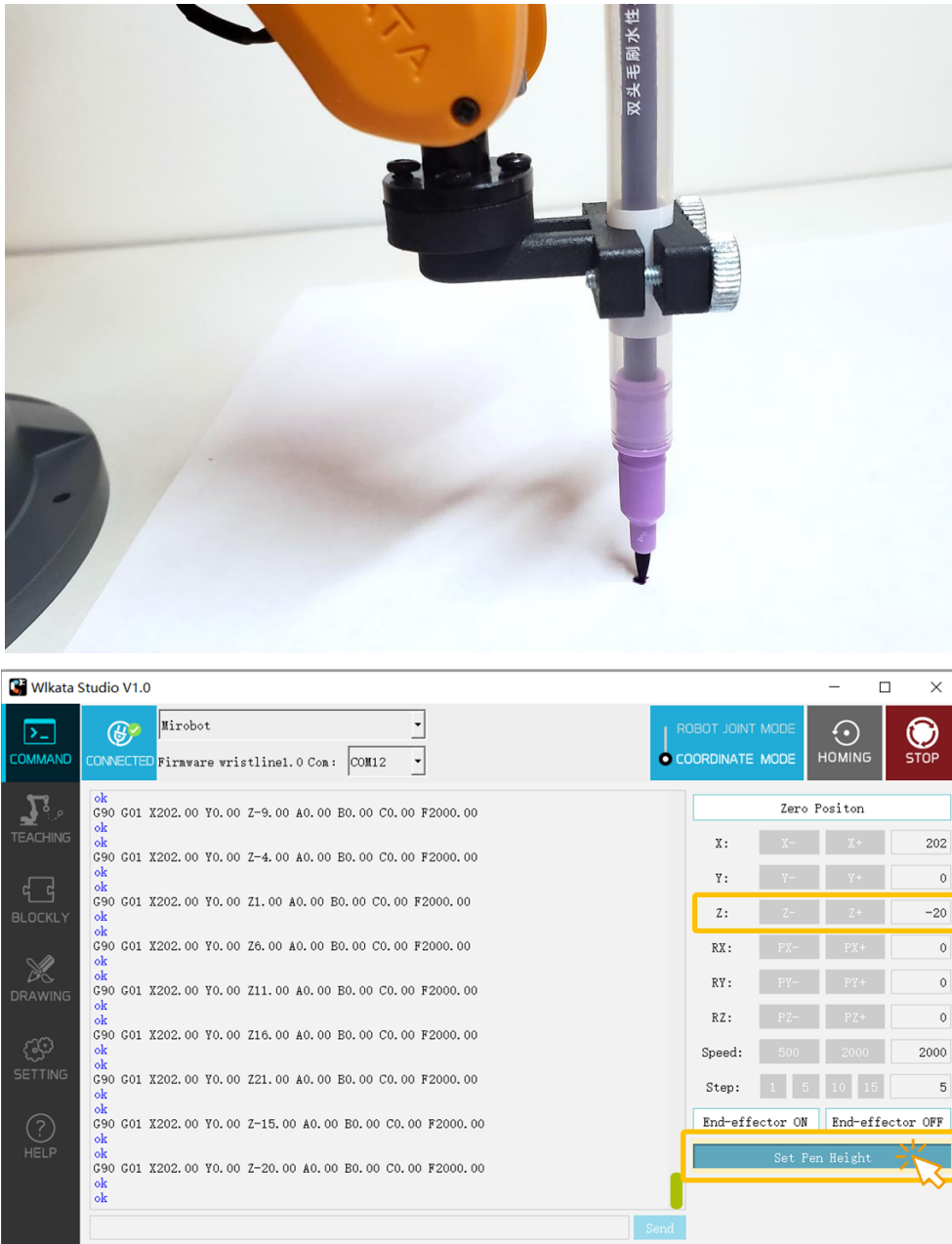

Figure 3.36 Setting the pen height before drawing

Letting the manipulator draw

(7) Click the **DRAWING** tab in the software to switch to the drawing page.

(8) To add a graph from existing files, you can either choose an example from the upper right panel 2 **Examples**, or insert a graph by click **Insert** button. The graph you have chosen should be shown in the center canvas. As show in Figure 3.37.

(9) To add a text graph, typing in the lower right panel 3 and click **Add** button, and the text you have typed should be placed in the center canvas, as shown in Figure 3.37.

(10) To add a mouse drawing graph, click the **Select | Pen** button to switch from the **Select** mode to the **Pen** mode. And then you can use your mouse as a pen to draw on the center canvas, as shown in Figure 3.38.

(11) To adjust the size and position of the graph, ensure the **Select | Pen** button is in the **Select** mode → click the graph in the canvas and a resize frame would appear around the graph. Adjust the corners to resize the graph and drag the inner frame to change the position of the graph. As shown in Figure 3.37.

(12) To delete the unwanted graph on the canvas, ensure the **Select | Pen** button is in the **Select** mode → choose the unwanted graph on the canvas → click **Delete** button.

(13) To start the drawing, click **Run** button, and the manipulator will draw the graph(s) on the canvas. Figure 3.39

(14) To start over from a blank canvas, click **New** button to clear the canvas.

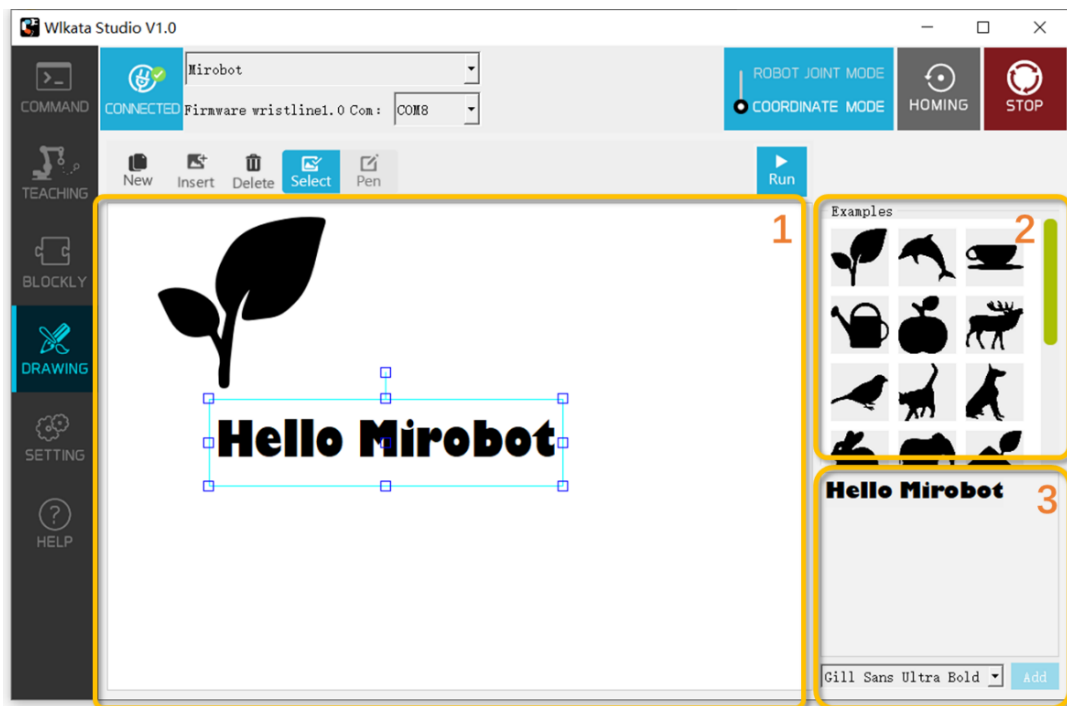

Figure 3.37 Inserting graph to the center canvas in the DRAWING page

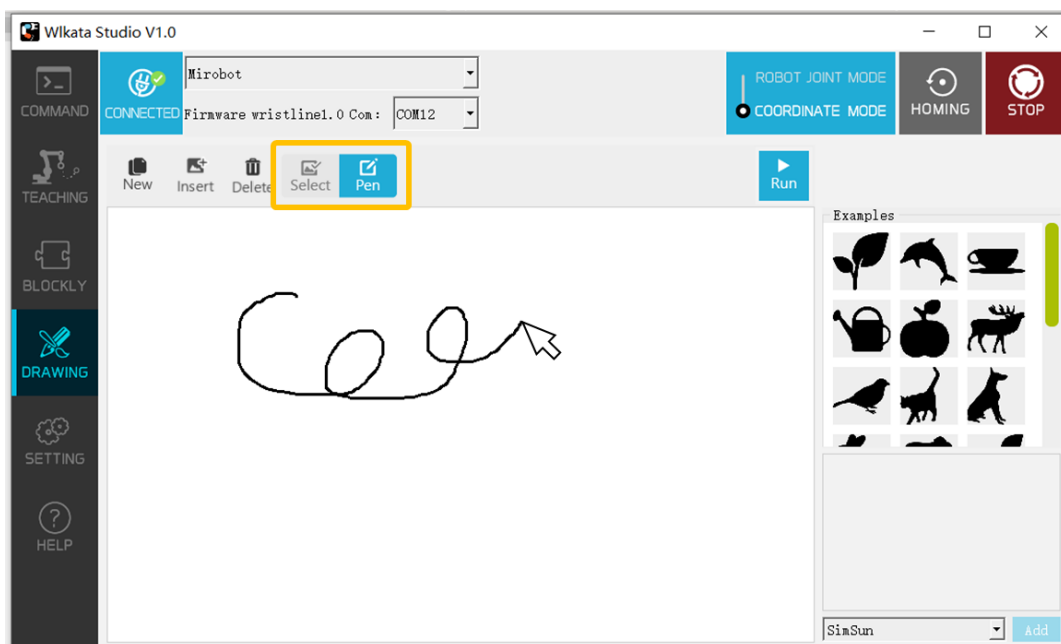

Figure 3.38 Switching from Select mode to Pen mode to draw by mouse

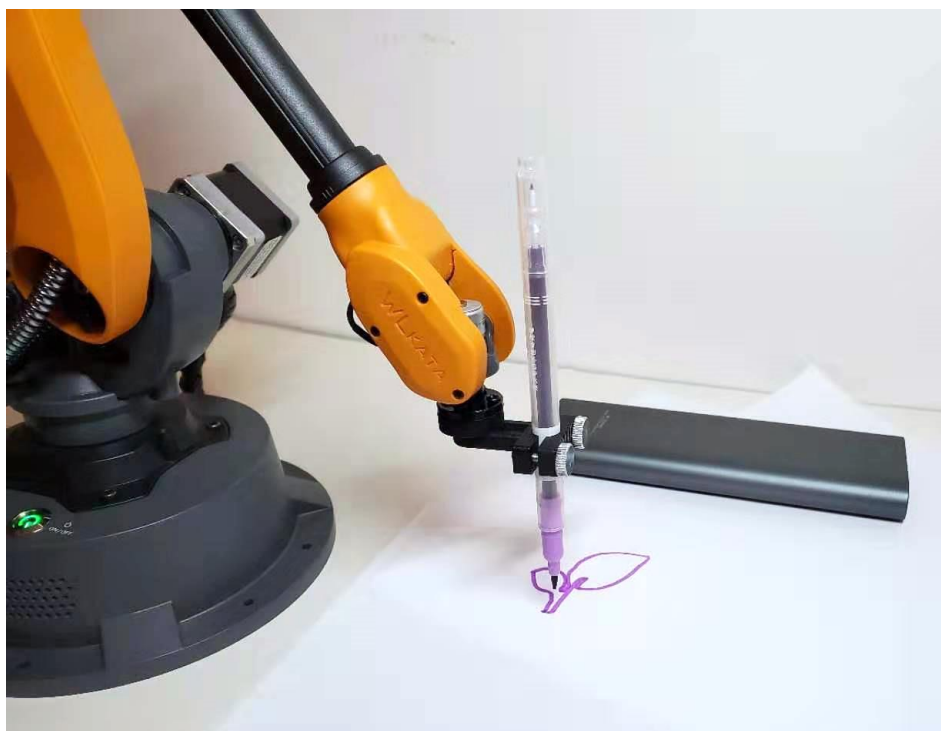

Figure 3.39 Drawing by WLKATA Mirobot

3.5 Using the teach pendant (Bluetooth controller)

3.5.1 Product description

Mirobot Bluetooth teach pendant is a Bluetooth controller for wirelessly controlling Mirobot desktop robotic arm. It supports each axis control mode, Cartesian control mode and teaching record mode.

After the Mirobot robotic arm is connected to the Bluetooth teach pendant, you can use this teach pendant to control the movement of the Mirobot robotic arm, which is convenient for users to understand and use the Mirobot robotic arm.

3.5.2 Product function and parameter description

3.5.2.1 Bluetooth teach pendant appearance and parameters

The shape design of the Bluetooth teach pendant combined with ergonomics allows users to easily control and operate with both hands.

Product Name	Mirobot Teach Pendant
Product Size	Long: 145±2mm Width: 113±2mm Height: 31±2mm
Weight	170g
Power	1000mAh
Voltage	3.7V
Operating Temperature	-10°C~45°C

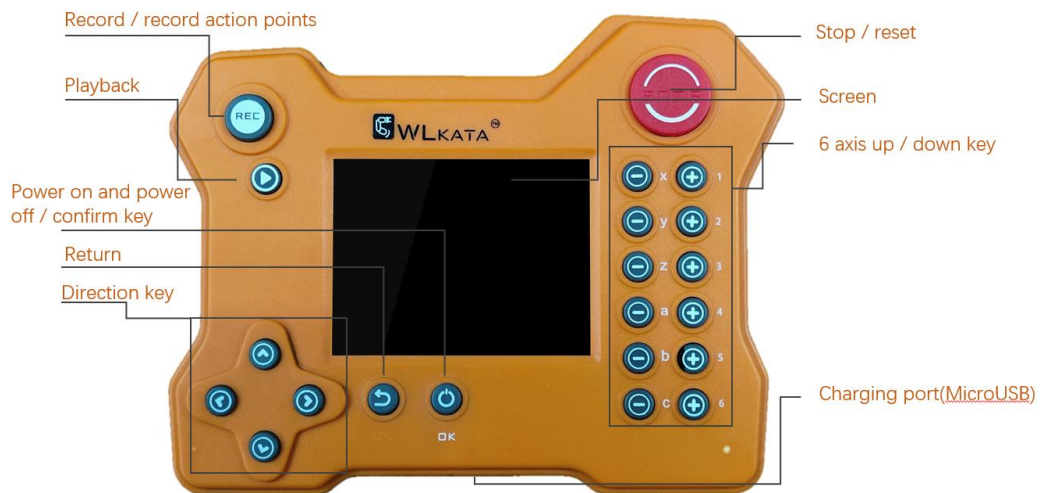

Figure3.40 Appearance of Mirobot teach pendant

3.5.2.2 Teach pendant control page composition and main function description

The Mirobot teach pendant is mainly composed of angle mode, coord. mode, record and setting function pages.

(1) Angle Mode page

The angle mode page is mainly responsible for the motion control of each axis of the manipulator.

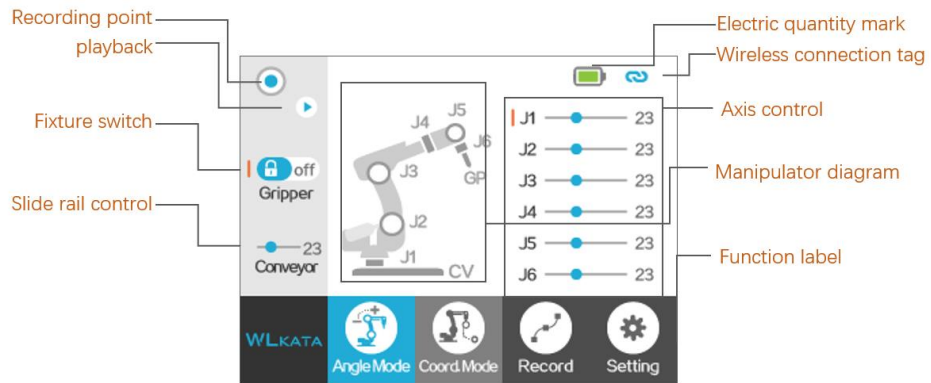

Figure 3.41 Function description of angle mode page and button

(2) Coord Mode page

Coord mode page is mainly responsible for the movement control of the manipulator in Cartesian mode.

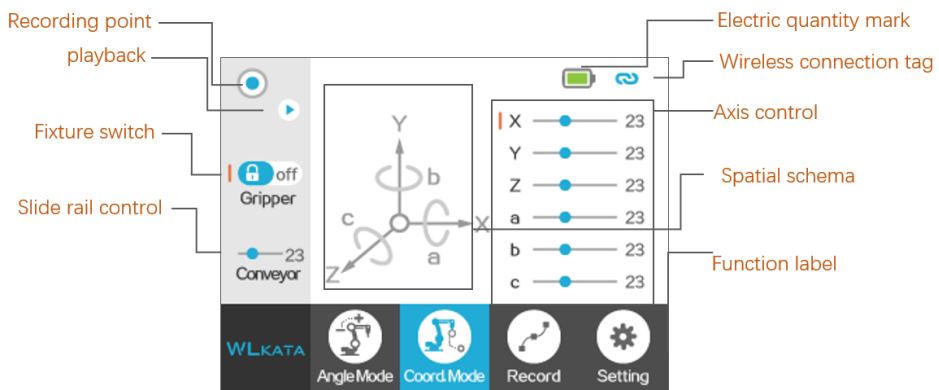

Figure3.42 Coord mode page and button function description

(3) Record page

The record page is mainly responsible for the teaching and recurrence of the manipulator.

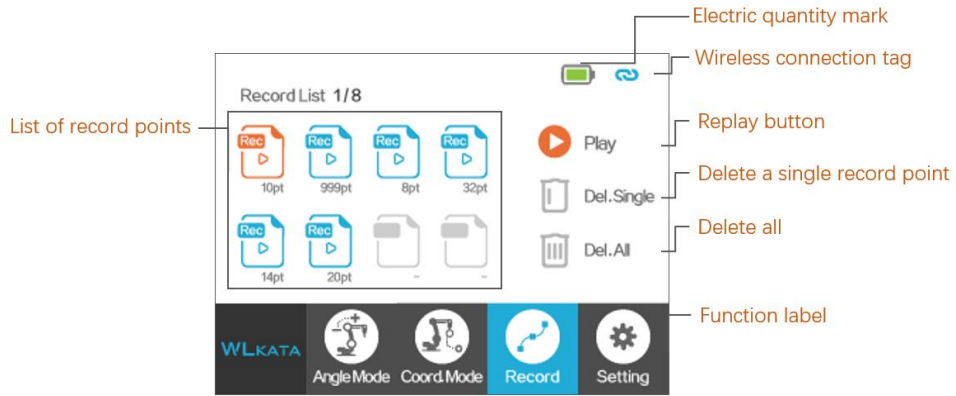

Figure3.43 Record page and button function description

(2) Setting page

The setting page is mainly responsible for the speed control of the manipulator and Bluetooth connection.

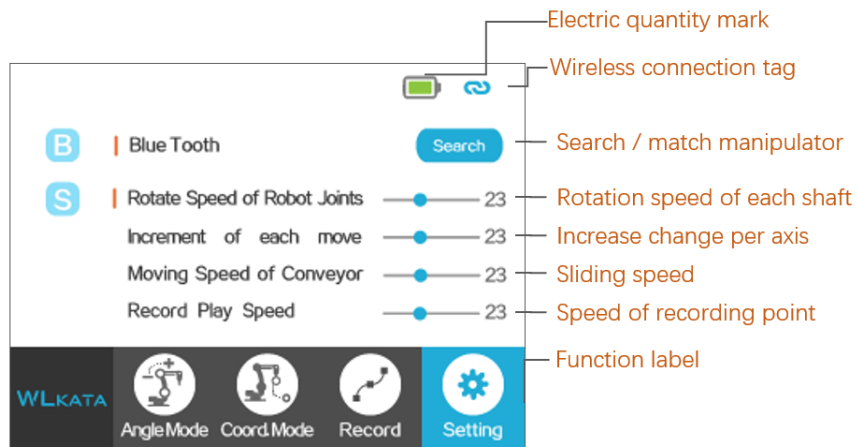

Figure3.44 Setting page and button function description

3.5.3 Operation Guide

3.5.3.1 Power ON/OFF

Press and hold the power button on the Bluetooth teach pendant for three seconds to open the teach pendant. Press the same button for three seconds to shut down. The switch button position is shown in Figure3.45.



Figure3.45 Bluetooth teach pendant on and off button

3.5.3.2 The connection process of the Bluetooth teach pendant and Mirobot manipulator

(1) Connect the Bluetooth extension module and the communication extension interface on the back of the Mirobot manipulator base, as is shown in Figure 3.46.

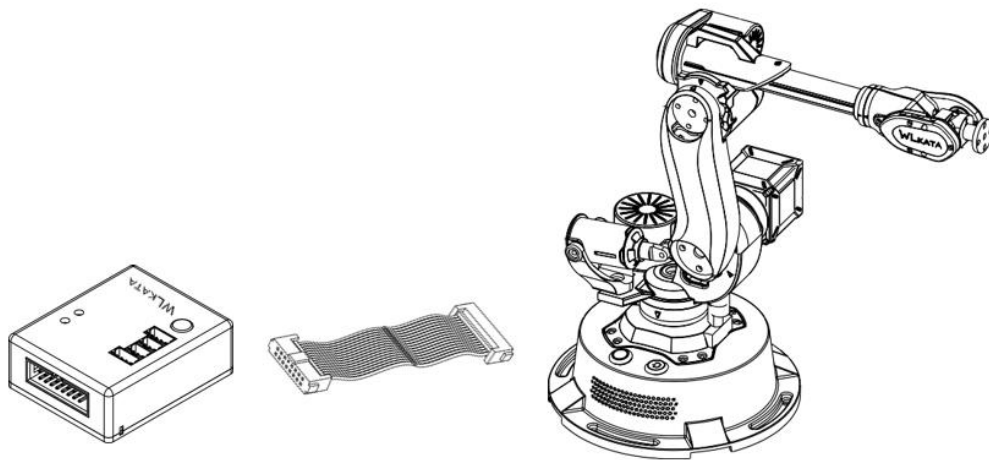

Figure3.46 The connection between Bluetooth extension module and Mirobot manipulator

(2) Turn on the power of the manipulator. At this time, the red LED on the Bluetooth extension module starts to flash, indicating that it is waiting for the Bluetooth teach pendant to connect. The location of the red LED is shown in Figure 3.47.

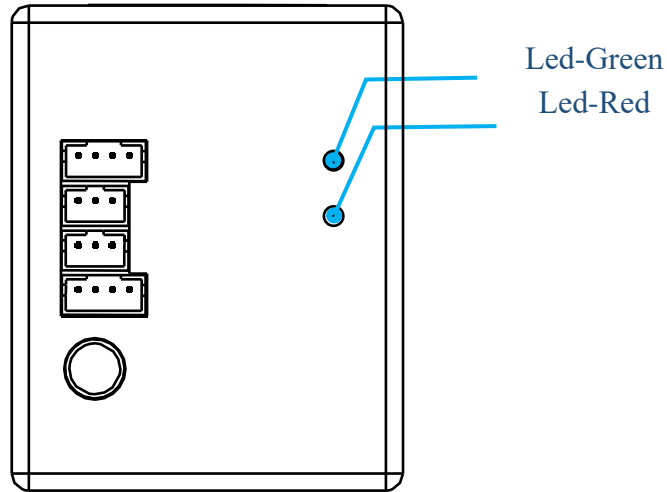

Figure3.47 LED light on Bluetooth expansion module

(3) Switch the control page tab on the teach pendant to the setting page, as is shown in Figure 3.48.

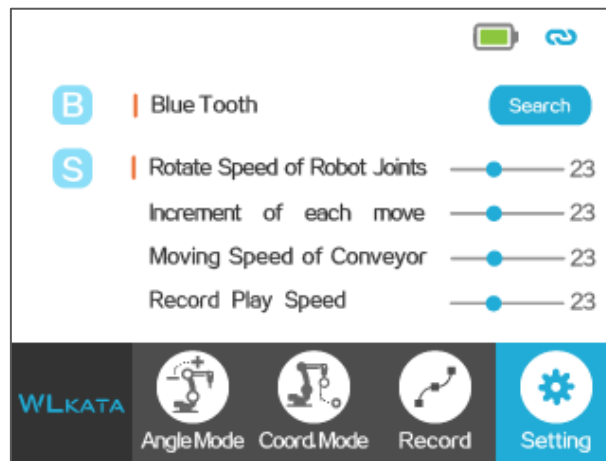

Figure3.48 Setting page on Bluetooth teach pendant

(4) Click the “Search” button, the button will change to “Searching”, wait a few seconds, and then it will change to “link”. Then click the “link” button to connect successfully, as is shown in Figure 3.5. After the connection is successful, the red LED is always on, and the green LED is on.

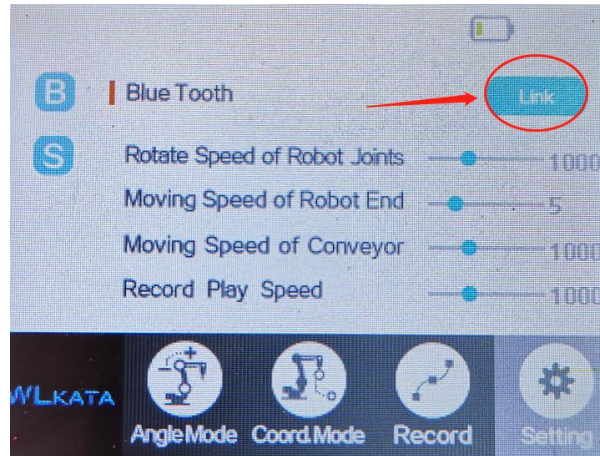

Figure3.49 Link button

3.5.3.3 Example of using the teach pendant single axis angle mode to control the robotic arm

(1) Switch the Bluetooth teach pendant interface to the angle mode interface, as is shown in Figure 3.50.

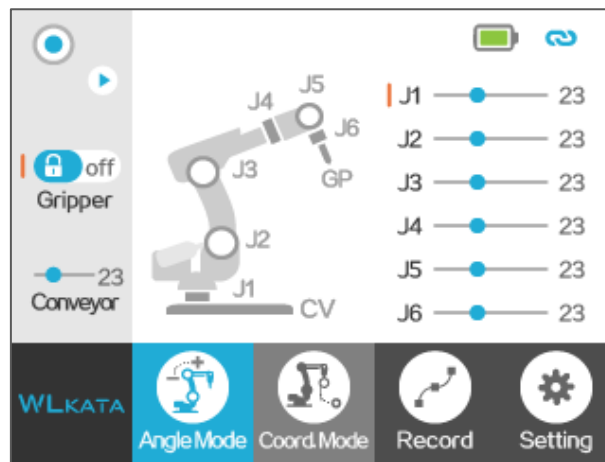

Figure3.50 Angle mode interface of Bluetooth handle

(2) First of all, it is necessary to reset the manipulator. Press and hold the red button on the top right of the teach pendant for 3 seconds, and the robotic arm will start to reset. Wait for the successful reset of the robotic arm, and then continue to operate. The reset button is shown in Figure 3.51.



Figure3.51 Reset button

(3) Press the 6 groups of buttons on the right side of the Bluetooth teach pendant to control the 6 corresponding rotating axes of the manipulator to move in the positive and negative directions, as is shown in Figure3.52.



Figure3.52 The 6 sets of buttons to control the rotation of each axis

3.5.3.4 Example of cartesian mode control using teach pendant

(1) Switch the teach pendant interface to the Coord.Mode interface (also can go to the Angle Mode interface). As shown in Figure 3.53.

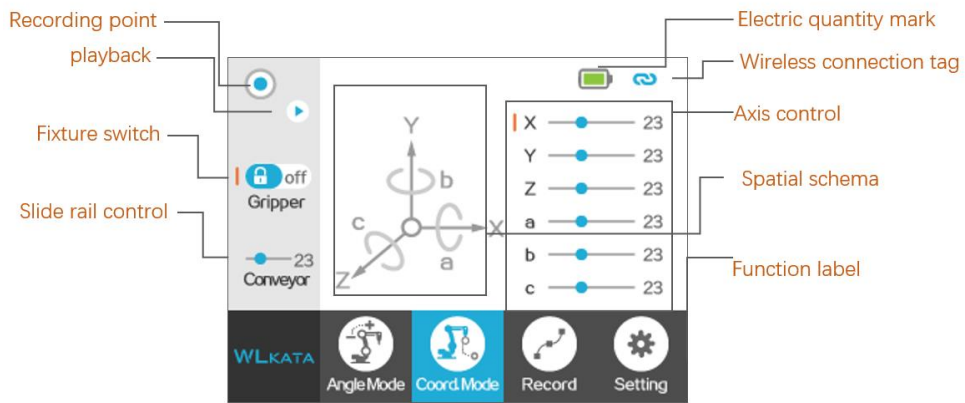

Figure 3.53 Coord. Mode interface of Bluetooth teach pendant

(2) The robotic arm needs to be reset once. Press and hold the red button on the upper right of the teach pendant for 3 seconds. The robotic arm will start to reset. Wait for the robotic arm to reset successfully before continuing the operation. The reset button is shown in Figure 3.54.



Figure 3.54 Reset button

(3) Press the six groups of buttons on the right side of the teach pendant to control the coordinates (x, y, z) and attitude (a, b, c) of the robot arm end respectively. As shown in Figure 3.55.



Figure 3.55 The 6 groups of buttons converted to control the end position and orientation

3.5.3.5 Teaching record and reproduction process

(1) After the Mirobot teach pendant is connected to the robot arm, select the Cartesian mode (or angle mode). Then press and hold the **REC key** until the outer circle of the recording point in the upper left corner of the screen lights up to enter the teaching mode, as shown in Figure 3.12.



State 1: The outer ring is off and the teaching mode is not entered.

State 2: The outer ring lights up and enters the teaching mode

Figure 3.56 Enter teaching mode

(2) When the Mirobot is controlled to move to a certain position (or change the end fixture enable status) through the teach pendant, click the **REC button** to record the current position (or the current end fixture enable status). Then move to the next position, click the **REC button** to record the current position (or the current end fixture enable state).

(3) After the recording is completed, press and hold the **REC button** and wait until the recording point in the upper left corner of the screen goes out to complete the teaching recording (the outer circle of the recording point goes out).

(4) Enter the Record page and click Playback to play the first teaching file in the Record page by default. To play other files, enter the Record page and select the corresponding file. Click the OK button or touch the Play icon for 3 seconds.

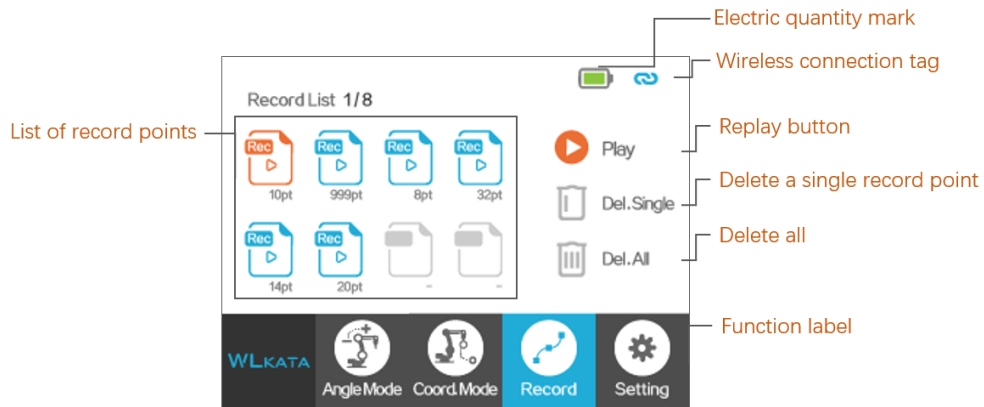

Figure 3.57 Record page

3.5.4 Cautions and Disclaimers

Before using the Mirobot Bluetooth remote control, please read the product manual carefully. The operation and system developers of the Bluetooth remote control must first read the manual carefully and use this remote control strictly in accordance with the operation guide.

Observe the following when using a Bluetooth remote control:

- When placing the remote control, be sure to handle it gently. Follow the instructions on the packing box and place it in the direction of the arrow. Otherwise, the machine may be damaged.
- Please use the remote control within the specified environment. Use beyond the conditions of the remote control will shorten the service life and even damage the equipment, causing personal injury and property damage.
- Do not place the Bluetooth remote control in a humid environment or immerse it in liquid. The short circuit of the internal circuit will damage the remote control. When you accidentally spill water on the remote control, you should immediately turn off the power and wait for the remote control to be used in natural air-dry conditions.
- Children must be monitored by adults during use. It is strictly forbidden for children to bite the remote control button.

- If this product is discarded, please follow relevant laws to properly dispose of industrial waste and protect the environment.

3.5.5 Disclaimers

To the maximum extent permitted by law, the products described in this manual (including its hardware, software, etc.) are provided "as is" and may have defects, errors or malfunctions. Beijing Qiniu Chuangzhi Technology Co., Ltd. does not provide any form of express or Implied warranties, including but not limited to warranties of merchantability, quality satisfaction, suitability for a particular purpose, and non-infringement of third party rights; nor does it impose any special, incidental, incidental, or indirect damages resulting from the use of this manual or the use of our products Compensation.

Before using this product, PLEASE read this instruction manual and related technical documents published on the Internet and understand the relevant information to ensure that you can use the product on the premise of fully understanding the relevant knowledge. Beijing Qiniu Chuangzhi Technology Co., Ltd. recommends that you use this product under the guidance of professionals. All safety information contained in this manual should not be regarded as a guarantee of the product. Even if the relevant instructions are followed, the harm or loss caused during use may still occur.

It is the responsibility of the user of this product to ensure that the applicable laws and regulations of the relevant country are followed, and that there is no major danger in the use of Beijing Qiniu Chuangzhi Technology Co., Ltd.

This product should be used in an environment that meets the requirements. If the product is modified without official authorization, the product cannot be used normally, or it may cause personal injury, electric shock, or fire. All consequences shall be borne by the user.

4 Working principle and specification

This chapter describes the working space, working principle, size and key technical specifications of WLKATA Mirobot .

4.1 Working space

The workspace of WLKATA Mirobot is shown in Figure 4.1.

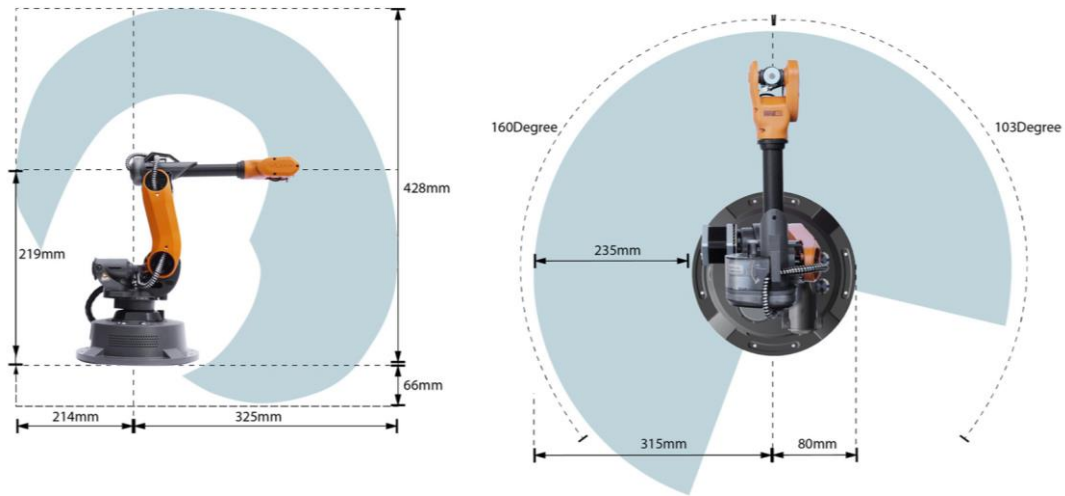

Figure 4.1 The workspace of WLKATA Mirobot

4.1.1 Coordinate system

WLKATA Mirobot has a six-joint coordinate system and a Cartesian space coordinate system as shown in Figure 4.2 and 4.3, respectively.

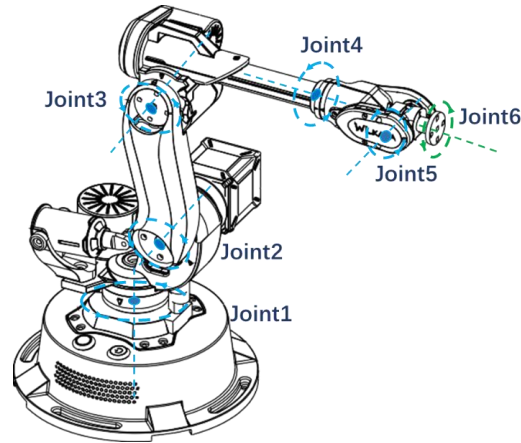

Figure 1.2 Six-joint coordinate system Of WLKATA Mirobot

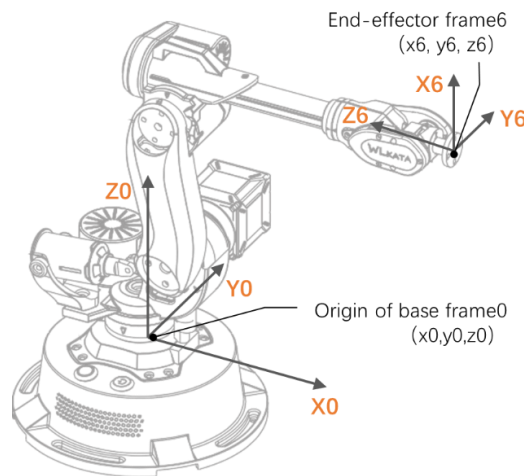

Figure 1.3 Reference frame (Cartesian space coordinate system) of WLKATA Mirobot

1 Joint coordinate system: the coordinate system determined by reference to each moving joint.

- This manipulator has six joints: j_1 j_2 J_3 J_4 J_5 J_6 , all of which are rotary joints. The positive rotation direction of each joint follows the right-hand rule and the thumb points to the opposite direction of the output shaft of each shaft motor.

2 Cartesian coordinate system: The coordinate system is determined by reference to the base of the manipulator.

- The origin of the coordinate system is the center of the base platform.
- The x-axis direction is perpendicular to the fixed base forward.
- The y-axis direction is perpendicular to the fixed base to the left.

4.1.2 Sports function

The motion modes of Mirobot manipulator include Joint motion mode and Coordinate mode.

1 Joint motion mode:

the Joint motion mode means that each joint of the manipulator is controlled separately. You can click the joint motion button to move a single joint.

- Click "J1 +" and "J1 -" to control the positive and negative rotation of the base motor.
- Click "J2 +" and "J2 -" to control the positive and negative rotation of boom motor.
- Click "J3 +" and "J3 -" to control the positive and negative movement of jib motor.
- Click "J4 +" and "J4 -" to control the positive and negative rotation of the fourth axis at the end.
- Click "J5 +" and "J5 -" to control the positive and negative rotation of the fifth axis at the end.
- Click "J6 +" and "J6 -" to control the positive and negative rotation of the sixth axis at the end.

2 Cartesian motion mode:

The Cartesian motion mode of the manipulator controls the position and attitude of the en-effector. You can click the coordinate and RPY angle motion buttons to change the position and attitude of the end actuator.

- Click "x +" and "X -" to control the manipulator to move along the positive and negative direction of the X-axis.
- Click "Y +" and "Y -" to control the manipulator to move along the positive and negative direction of the Y-axis.
- Click "Z +" and "Z -" to control the manipulator to move along the positive and negative direction of the Z-axis.
- Click "PX +" and "PX -" and the end posture of the manipulator rotates along the X-axis.
- Click "py +" and "py -" to rotate the end posture of the manipulator along the Y-axis.
- Click "PZ +" and "PZ -" and the end posture of the manipulator rotates along the Z-axis.



The Cartesian motion mode supports point-to-point motion mode and linear interpolation motion mode. Please refer to the WLKATA Mirobot communication instructions for specific modes information.

4.2 Technical specifications

4.2.1 Technical parameters

Figure 4.1 Parameter specifications

Parameter specification	
Axle number	6+1
Payload	150 g
Repeated positioning accuracy	0.2 mm
Communication Interface	USB / WiFi * / Bluetooth
Power supply voltage	100 V - 240 V, 50 / 60 Hz
Power input	12 V / 5A DC
Power	60W Max
Working environment	- 10 ° C - 60 ° C

Figure 4.2 Axis motion parameters

Axis motion parameters		
Shaft	working range	maximum speed
Axis 1	100 ° to + 100 ° 31 °	31° / s
Axis 2	- 600 ° to + 90 °	65° / s
Axis 3	- 180 ° to + 50 °	28° / s
Axis 4	- 180 ° to + 180 °	110° / s

Axis 5	- 180 ° to + 40 °	33° / s
Axis 6	-180 ° to + 180 °	66° / s

Figure 4.3 Physical characteristics

physical characteristics	
Net weight (manipulator and controller)	1.5kg
Round base size	< diameter160mm
Material of manipulator	Aluminum alloy, ABS engineering plastics
Controller	Arduino2560
Robot installation	Desktop
Package specification (L × w × h)	220mm ×160mm ×270mm
The dimension of standard outer box (L × w × h)	300mm x 200mm x 400mm

Figure 4.4 Application software

Application software	
Software	WLKATA Studio, grblcontroller3.6
SDK	Mirobot communication protocol and Mirobot function library
Expandable I / O interface	Step drive interface 1, I / O 4 (configurable as analog signal input (AD) or PWM output)

4.2.2 Technical parameters

The size parameters of WLKATA Mirobot are shown in Figure 4.5, and the installation hole size of its end flange is shown in Figure 4.6.

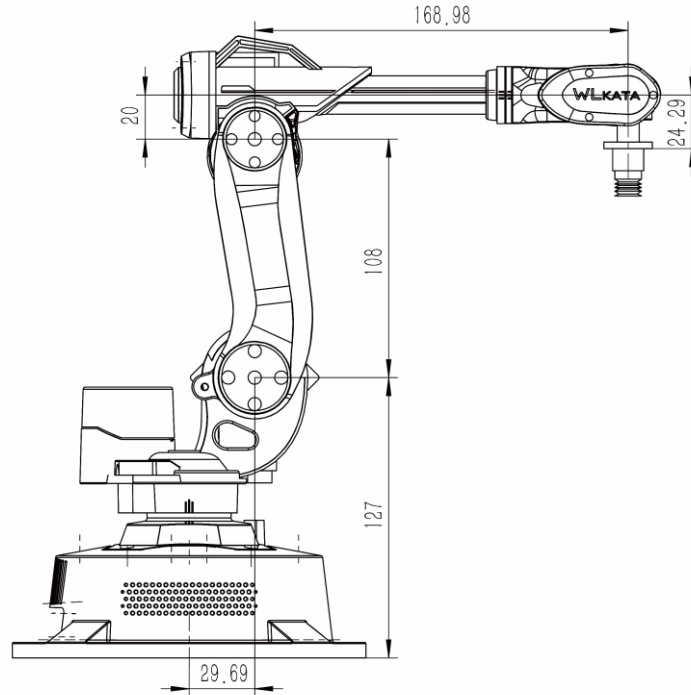

Figure 3.5 WLKATA Mirobot size parameters

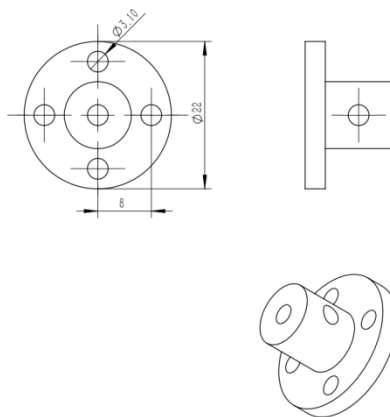

Figure 3.6 The end flange size of WLKATA Mirobot

5 Interface description

5.1 Interface board of the manipulator

The interface is located at the back of the base of the WLKATA Mirobot , and the schematic diagram of the base interface is shown in Figure 5.1.

Figure 5.1 Back interface of substructure

The PIN of the extended communication interface and the definition of each pin is shown in Figure 5.1.

- Ex0 represents the output of pwm1, and EX1 represents the output of pwm2. 1b, 2b, 1a, and 2A refer to the four interfaces of the external sliding rail stepping motor.

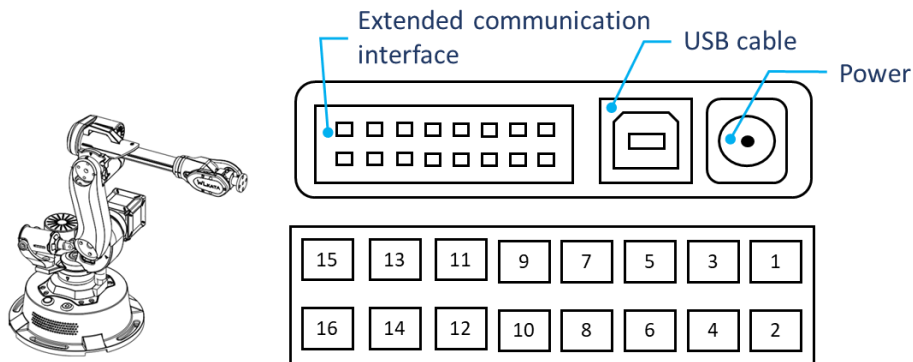

15	13	11	9	7	5	3	1
2A	2B	EX0	5V	GND	GND	RX_3	RX_2
16	14	12	10	8	6	4	2
1A	1B	EX1	-	-	-	TX_3	TX_2

Figure 5.1 PIN and Pin definition of back extension communication interface of substructure

5.2 Interface board of the Extender Box

The WLKATA Mirobot external communication interface needs to be connected with the external expansion interface board (the Extender Box) by using an IDC cable. The common external interface board of WLKATA Mirobot and the Pin definition is shown in Figure 5.2.

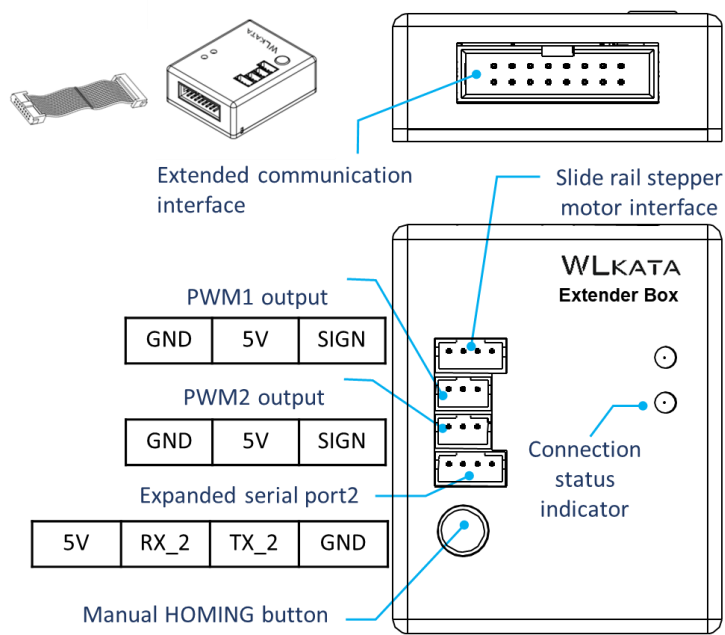

Figure 4.4 Mirobot general external interface board (Extender Box) and the Pin definition diagram

Appendix I

WLKATA Mirobot Calibration Operation

Calibration Operation Procedure:

The Mirobot is calibrated before leaving the factory. In each time the manipulator finishes the HOMING action, the joint 1, joint 2, joint 3, joint 4 and joint 5 should be homed to the pre-designed homing position, as shown in Figure A1.

After the HOMING action, if one or more of the joints is/are not in the pre-designed homing position, one need to re-calibrate the manipulator. The Calibration procedure is explained as below:

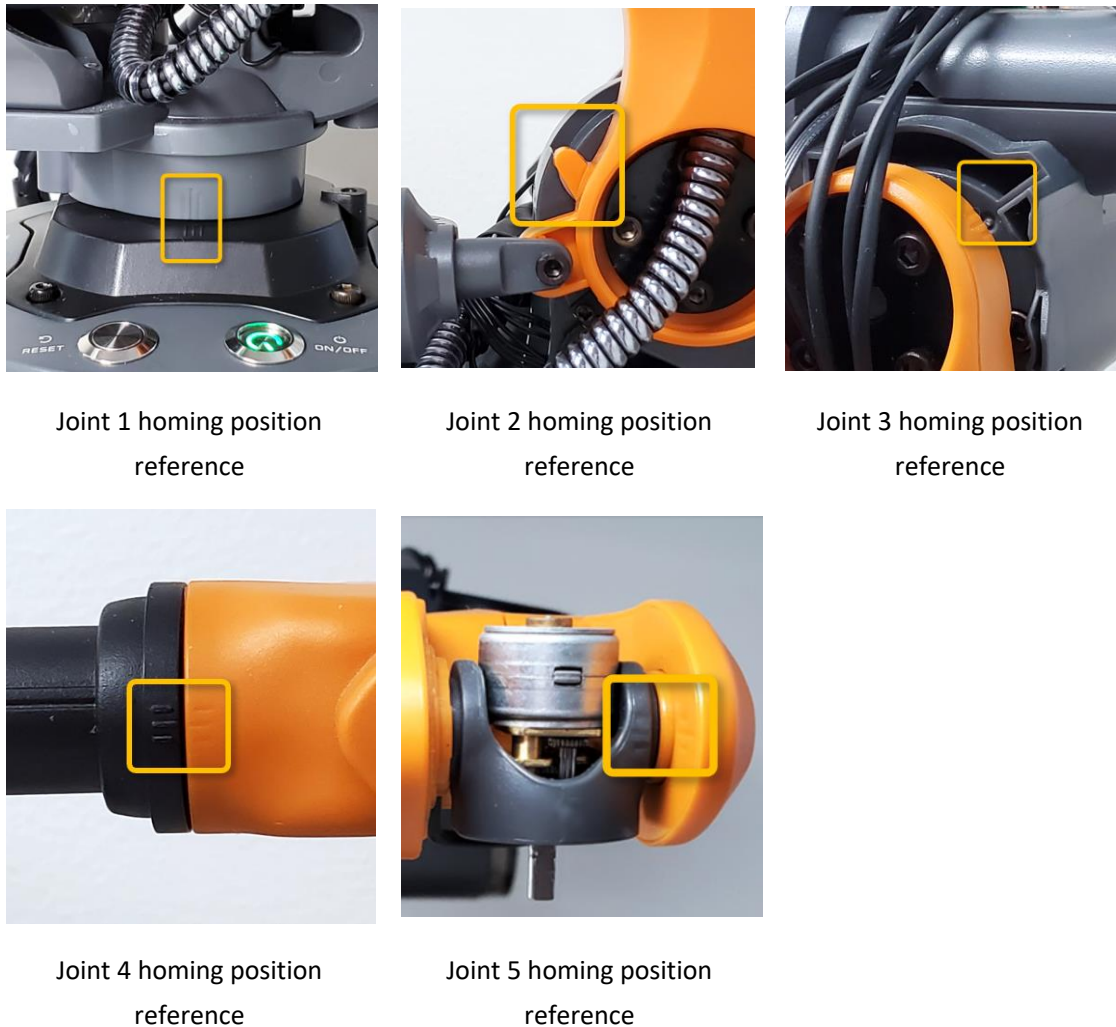

Figure A1 Pre-designed homing position of the Joint 1 to Joint 5

- (1) Connect the Mirobot manipulator to the computer with USB cable, and turn on the power supply.
- (2) Open the Wlkata Studio.exe software interface. Ensure the WLKATA Studio shows a **CONNECTED** icon which indicates the manipulator is connected to the software.
- (3) Click **SETTINGS** tab, and the Settings menu would pop-up, as shown in Figure A2.
- (4) Click the **Start** button under the Calibration section, and click **Yes** in the pop-up window to start the calibration, as shown in Figure A3.
- (5) Keep the Settings window open, switch the **COMMOND** page and switch the control mode to **ROBOT JOINT MODE**.
- (6) On the right panel, click the **J+ J-** control buttons to adjust the positions of the J1 to J5 to the pre-designed homing positions (as shown in Figure A1).
- (7) When the Joint 1 to Joint 5 are all in the pre-designed homing positions, click **Finish** button in the Setting window to finish the calibration procedure.

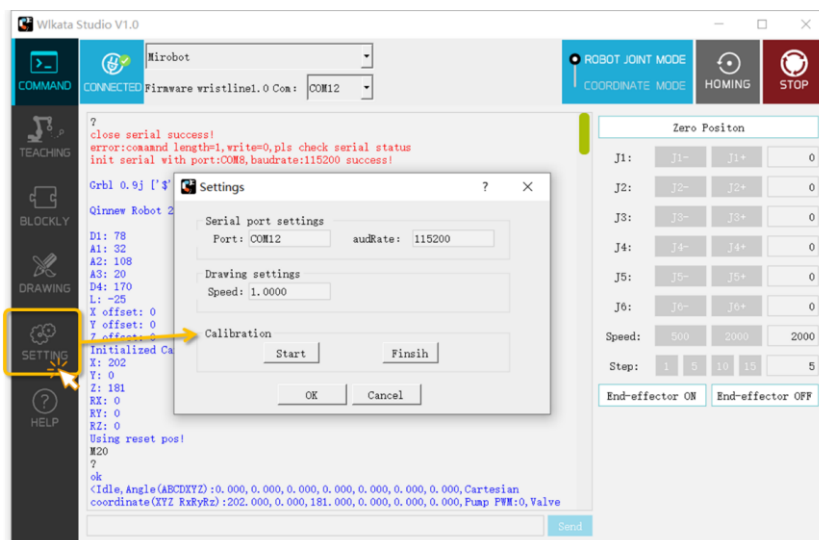

Figure A2 The Calibration in the Settings menu

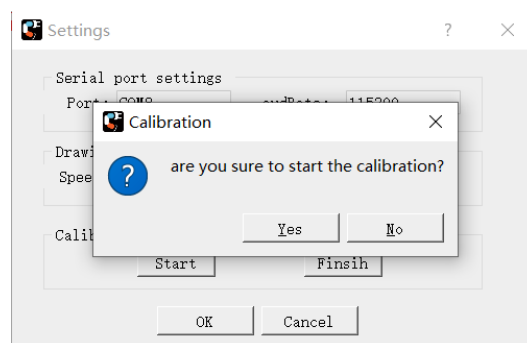

Figure A3 Start the Calibration procedure

Appendix II

Trouble shooting list of WLKATA Studio and Mirobot

1. Upgrading to a newer version WLKATA Studio

You could find and download the newest version of WLKATA Studio on www.wlkata.com.

Before installing a new version of WLKATA Studio, remember to clear the local record of Wlkata Studio in the AppData directory:

- (1) Go to the directory of `C:\User\(User Name)\AppData\Local\` , delete the whole folder of Wlkata Studio in this file path.
- (2) Find the old version of Wlkata Studio.exe directory, and delete the whole folder.
- (3) Decompress the new version of WLKATA Studio software package to a **local root directory** such as D:\ or E:\ to avoid potential foreign language character disturb.
- (4) Double-click Wlkata Studio.exe in the directory and start to use the WLKATA Mirobot.

2. If you want to put the mirobot back into the box, please adjust the Mirobot to the position shown below.

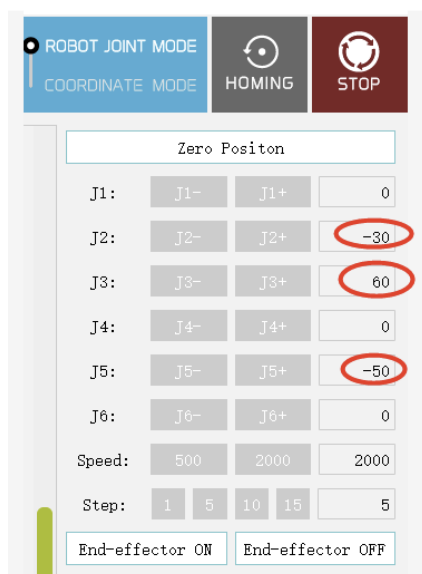

3. The first axis sensor failure problem

(we will improve this hardware issue in the next version of WLKATA Mirobot)

Cause: The sensor plug is loose or the one-axis screw is loose, resulting in the sensor not detecting the magnet. Follow the steps in below to solve this problem:

Firstly, tighten this screw a little bit:



Secondly, in the WLKATA studio, do the next 8 steps:

1	Enter \$ 20 = 0 and \$ 21 = 0 (Remove software limit)
2	Enter M50 to unlock the motor
3	Click J1 to turn the first axis to the position of the scale line to align
4	Click Homing to see if the reset is successful
5	Stop immediately if the magnet position is exceeded
6	If you still have any questions, please contact customer service
7	If successful, please enter \$ 20 = 1 and \$ 21 = 1
8	Then you should be able to use it normally

