

EXTERNAL ROOF SOLUTION

765, 1140 & 2010m³/h

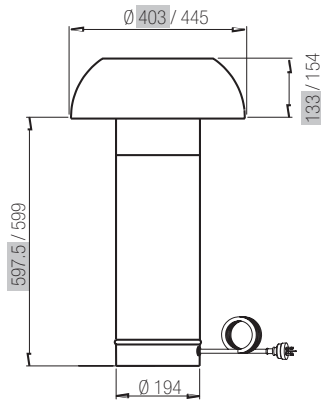

ER-765/1140 Dimensions
ER-2010 Dimensions

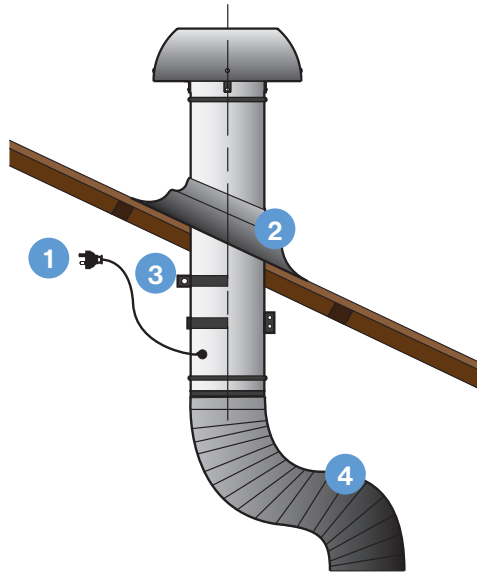

1. Fan power supply connects to internal hood unit
2. Tile or metal roof flashing (optional accessory)
3. Rigid duct mount (optional accessory)
4. 200mm flexi ducting (attached to internal hood unit)*

**Advise to include gentle bend in duct run as well ensuring ducting is pulled tight and excess removed.*

We recommend to install the roof motor offset from rangehood to avoid direct noise travel.

EXTERNAL WALL SOLUTION

765, 1140 & 2010m³/h

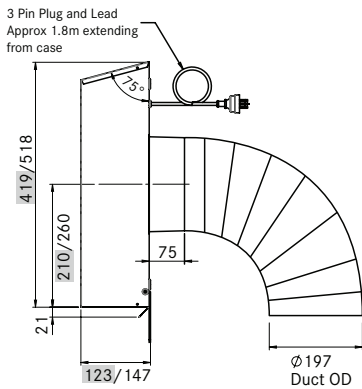

EW-765/1140 Dimensions
EW-2010 Dimensions

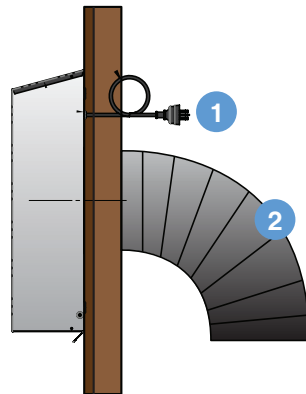

1. Fan power supply (connects to internal hood unit)
2. 200mm flexi ducting (attached to internal hood unit)*

**Advise to include gentle bend in duct run as well ensuring ducting is pulled tight and excess removed.*

IN-ROOF MOTOR SOLUTION

765 & 1140m³/h

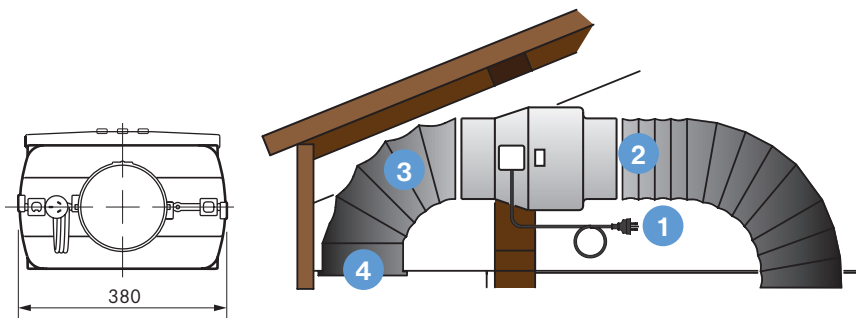

1. Fan power supply (attached to internal hood unit)
2. 200mm flexi duct installed between rangehood and motor inlet*
3. 200mm flexi duct installed between motor outlet and wall/eave vent
4. Vent installed in eave position

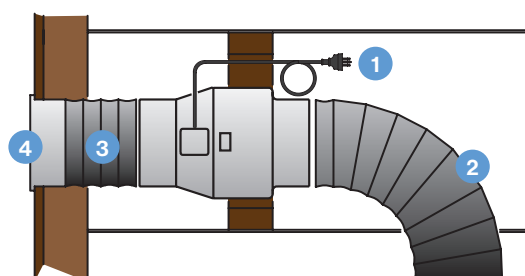
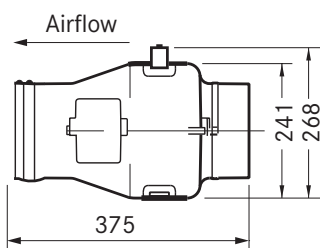

1. Fan power supply (attached to internal hood unit)
2. 200mm flexi duct installed between rangehood and motor inlet*
3. 200mm flexi duct installed between motor outlet and wall/eave vent
4. Vent installed in wall position

**Advise to include gentle bend in duct run as well ensuring ducting is pulled tight and excess removed.*

REMOTE MOTOR SOLUTIONS

REMOTE INLINE MOTOR 1300m³/h

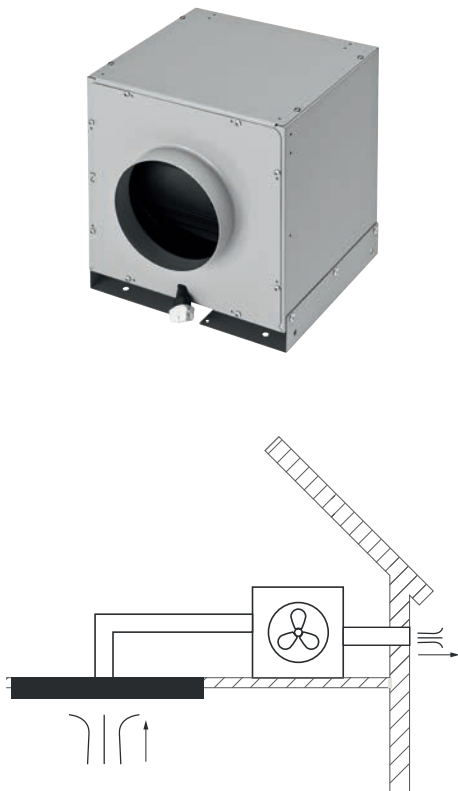

Inline fan for internal installation 1300m³/h. Includes 7 metres of cable. 200mm diameter duct connection.

Includes 6m flex ducting, duct clamps and wall/eave vent.

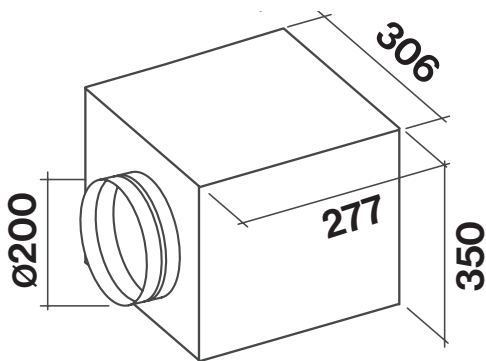

EXTERNAL WALL MOTOR 1000/1500m³/h



304 stainless steel construction with 200mm diameter duct connection. Can be paired with Cassette products only. Includes 7 metres of cable. 200mm diameter duct connection.

Includes 6m flexi ducting and duct clamps.

INSTALLATION NOTE: Must be shielded from external elements when installed.

EW1000

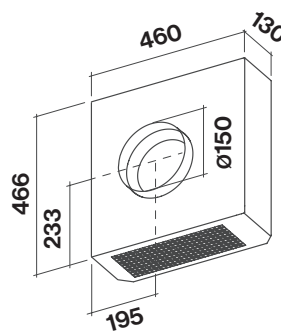

EW1500

