

Freeworld Auditorium

Inner City Ideas Cartel 1
71 Waterkant Street
Cape Town City Centre
021 8241781

Auditorium User Manual

Managed By NVD Property Management

Contact	Nina Van Deventer
Cellphone	0763362130
Email	nina@nvdproperty.co.za
Technician	Charl Van Zyl
Cellphone	0619505490
Email	atomicevents@gmail.com

Index:

1. Index
2. Venue Layout
3. Presentation Specifications
4. Stage Layout
5. Sound Layout
6. Video Layout
7. Lighting Layout
8. Rack Layout



Venue Layout

Inner City Ideas Cartel Auditorium Layout

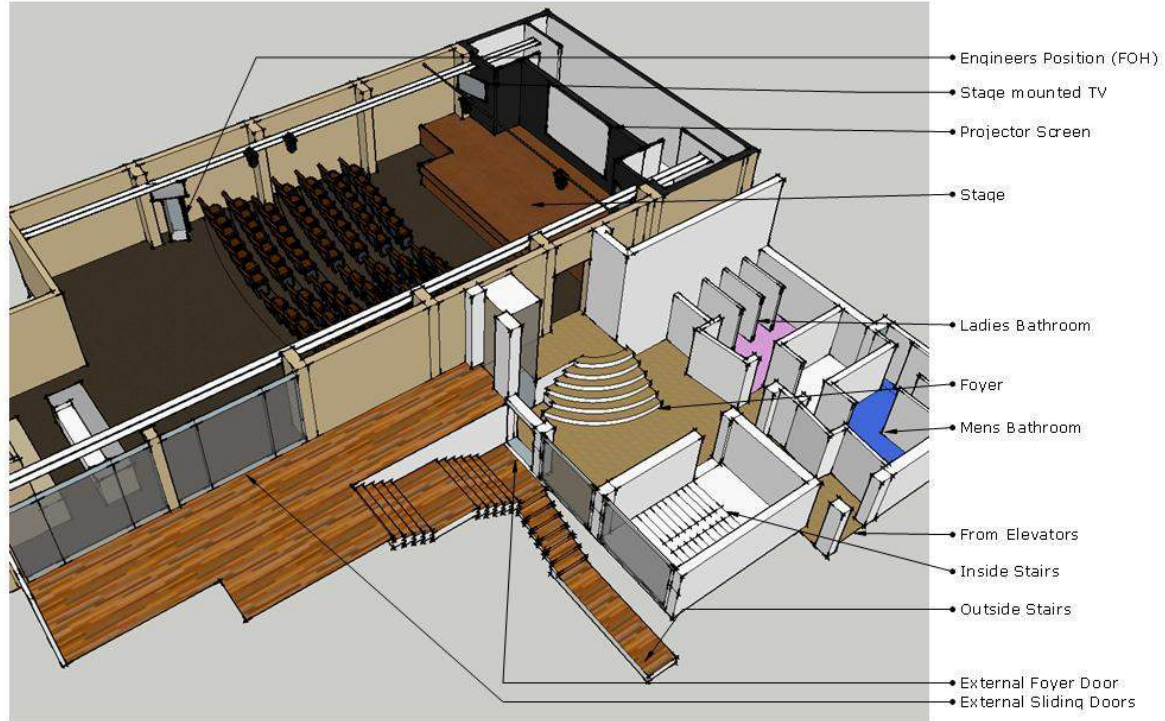

Inner City Ideas Cartel Auditorium Layout
- TOP VIEW

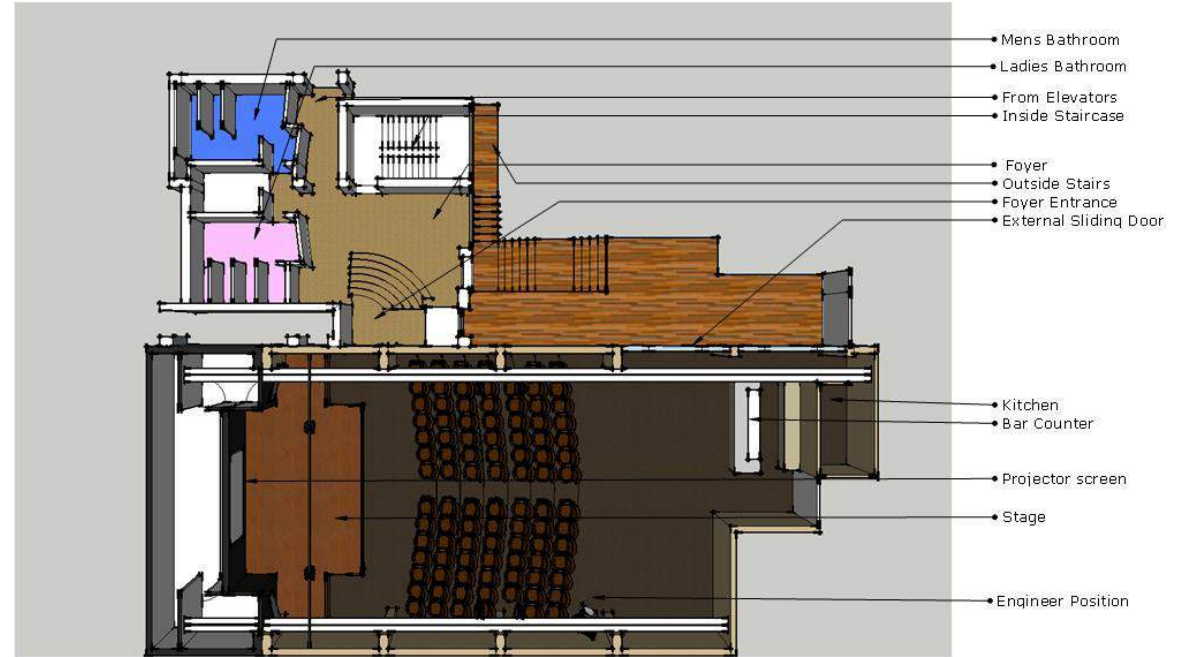

Formatting of Presentations

Video Format (Native Resolution)	16:10 & 16:9 WUXGA
Preferred format	1920 wide x 1200 high
Video Input	VGA

Presentations

The venue operator will provide a laptop (Running Windows 8.1) with Microsoft Powerpoint 2013. If your presentation is in Keynote or another presentation software, please provide a laptop with applicable software, and a VGA out converter. (Our system uses VGA)
You will be provided with a Presentation Clicker.
We provide one handheld wireless microphone and microphone stand.

Please try to keep the following in mind:

Video and sound

If you have video or audio in your presentation, it is always best to embed it. Take the presentation, and try it out on another computer to make sure all the media plays correctly.
Always bring a copy of the presentation to the venue, on the day of your event.

Multiple Presentations

It is a good idea to have all of the presentations loaded into one "Master Presentation". In other words, have all the presentations running consecutively in one file, with a Name Holder or Screen Holder separating the different presentations. This will result in a much smoother flow, and minimize waiting periods while sources are being switched.
If you have different Presenters, using Presentations in different formats, then you may either provide the computers for the additional video/presentation requirements, or these can be quoted on.
For Multiple Presentations, a stage assistant will be hired in at the clients expense, to facilitate and assist with additional tasks.

Media Testing and Dry Runs

You are welcome to email a copy of your media for testing at the Auditorium. We will take your media and do a full run through, and report on any issues that may arise. This would be charged for at the standard labour rate.
It is your responsibility to provide a hard copy of the presentation on the day of your event. (USB Stick, Or external hard drive)

Social Media

If you are running a twitter campaign, we can provide a Ipad with software that can run a live twitter feed with your hashtag. This feed can run in real time, or you have the option to moderate the tweets that appear on the big screen. This is subject to venue wifi at the time of your event, please enquire for pricing.

Prompters and Confidence Monitors

We can supply camera, stage and presidential prompters for Presenters that need assistance with big or complicated scripts, please enquire for pricing.

Media

Minimum Resolution: 720P, Preferably 1080P
Any Media / Video clips provided should be in the following digital formats : .avi / .mp4 / .mkv / .mov
Any large video files should be split into reasonable sizes (Max 1GB per Clip is preferable)
Images – JPEG and equivalent.

*Any **Static Pictures / Screen Holders** are to be provided in JPEG Format as follows:
1920 x 1080 or 1280 x 720 – For 57" Screens on Stage Left and Right, 1920 x 1200 for Projector
If in doubt, format to 1920 x 1200.*



Technical Equipment

Video Equipment

1 HD Projector // 2 x 57" HD Screens // 1 x 47" HD Screen (Back)

1 x Panasonic PT-DZ6700EL 6000 ANSI Projector	Set to 1920 x 1200 (16:10)
1 x 57" Sony HD Screen - Stage Left	Set to 1920 x 1080 (16:9)
1 x 57" Sony HD Screen - Stage Right	Set to 1920 x 1080 (16:9)
1 x 47" Sony HD Screen - Bar / FOH Position	Set to 1920 x 1080 (16:9)

1 x Kramer VP 8x8 Matrix Video Switcher

(Video Inputs) 4 Unique Sources Available

1 x VGA Input	- Stage Left (and Mini Jack Audio Input)
1 x VGA Input	- Stage Right (and Mini Jack Audio Input)
6 x VGA Inputs	- Technical FOH

Presentation Controller

1 x Logitech D400 Wireless Presentation Controller

Audio Equipment

7.2 Surround Sound Bose System (7 x Bose 151SEB / 2 x Bose MB4 Sub)

ClearOne Audio Management system

1 x Shure ULX / SM58 Handheld Wireless Microphone System

2 x Mini Jack Input - Stage Left and Right

1 x Allen and Heath ZED10FX audio mixer

Lighting

AMX Controlled Auditorium Lighting

AMX Controlled Stage Down-lights

The Stage and Intelligent lighting is operated with Avolites Titan One software

4 x Martin Mac 250 Krypton

2 x Martin Mac 250 Wash

4 x 500 Watt White Parcans - On Stage Truss

2 x 1000 Watt White Parcans - Mounted above audience / facing stage

4 x RGB Parcans - On Stage Truss

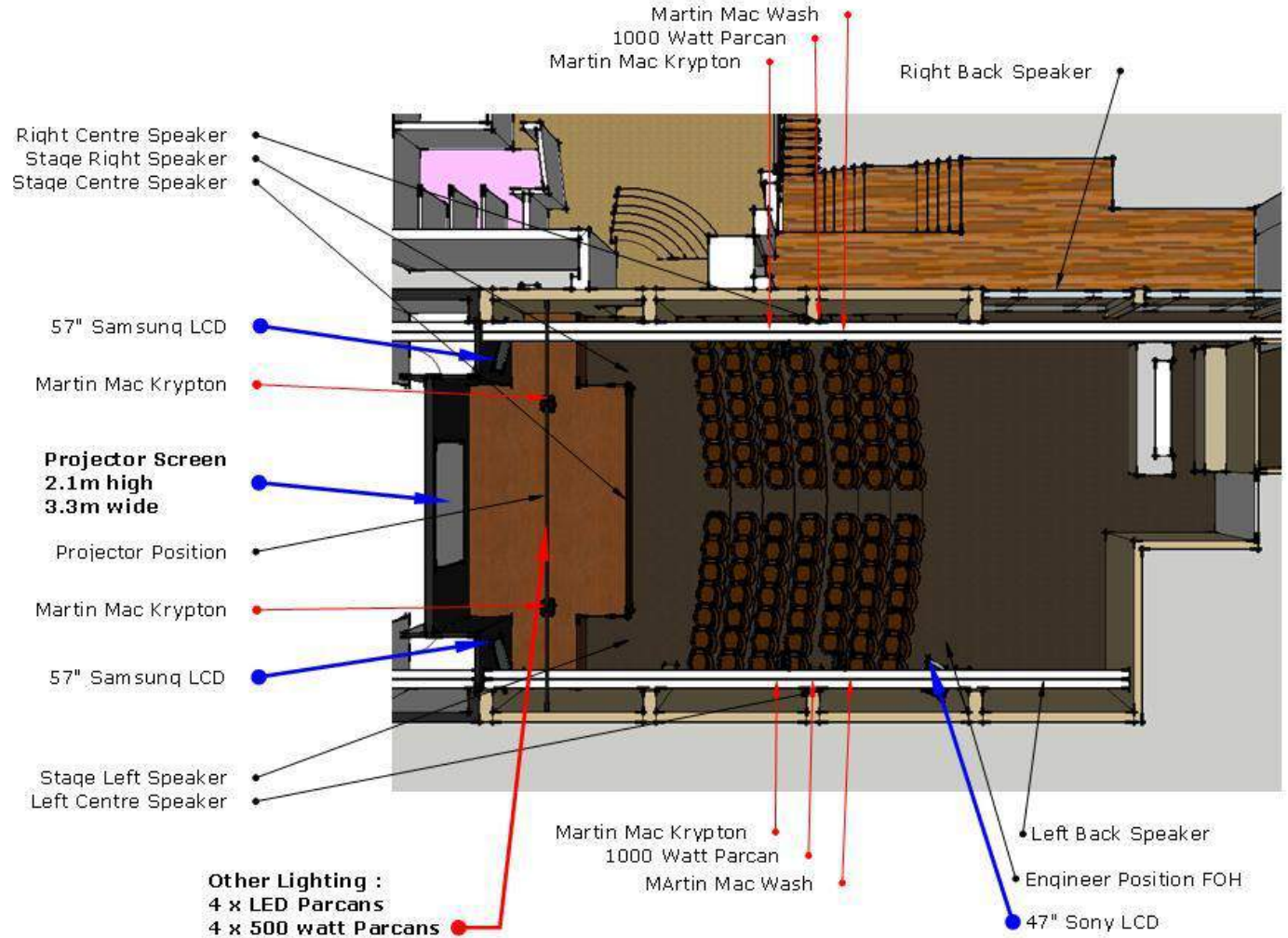

Video Layout

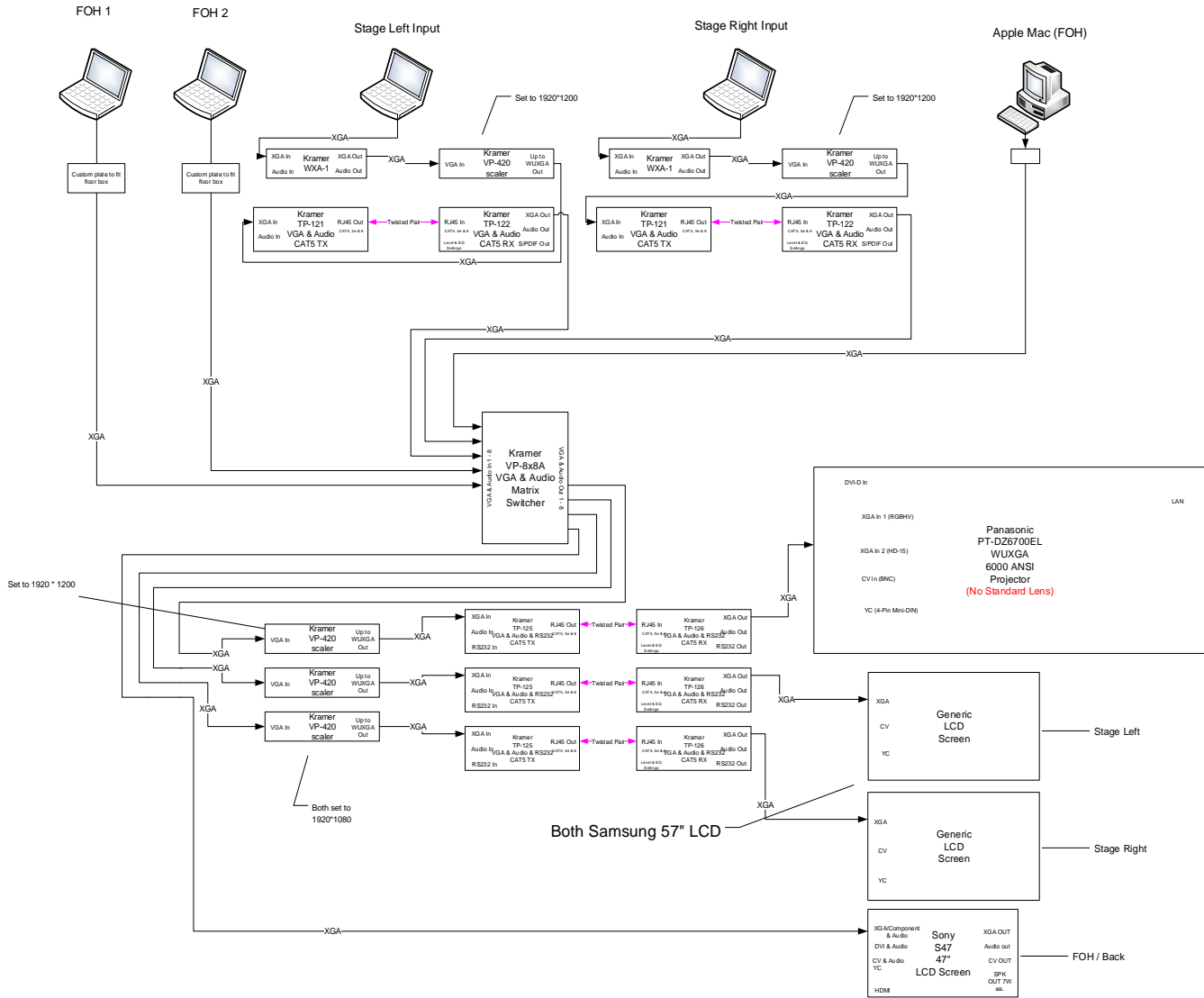

Audio Layout

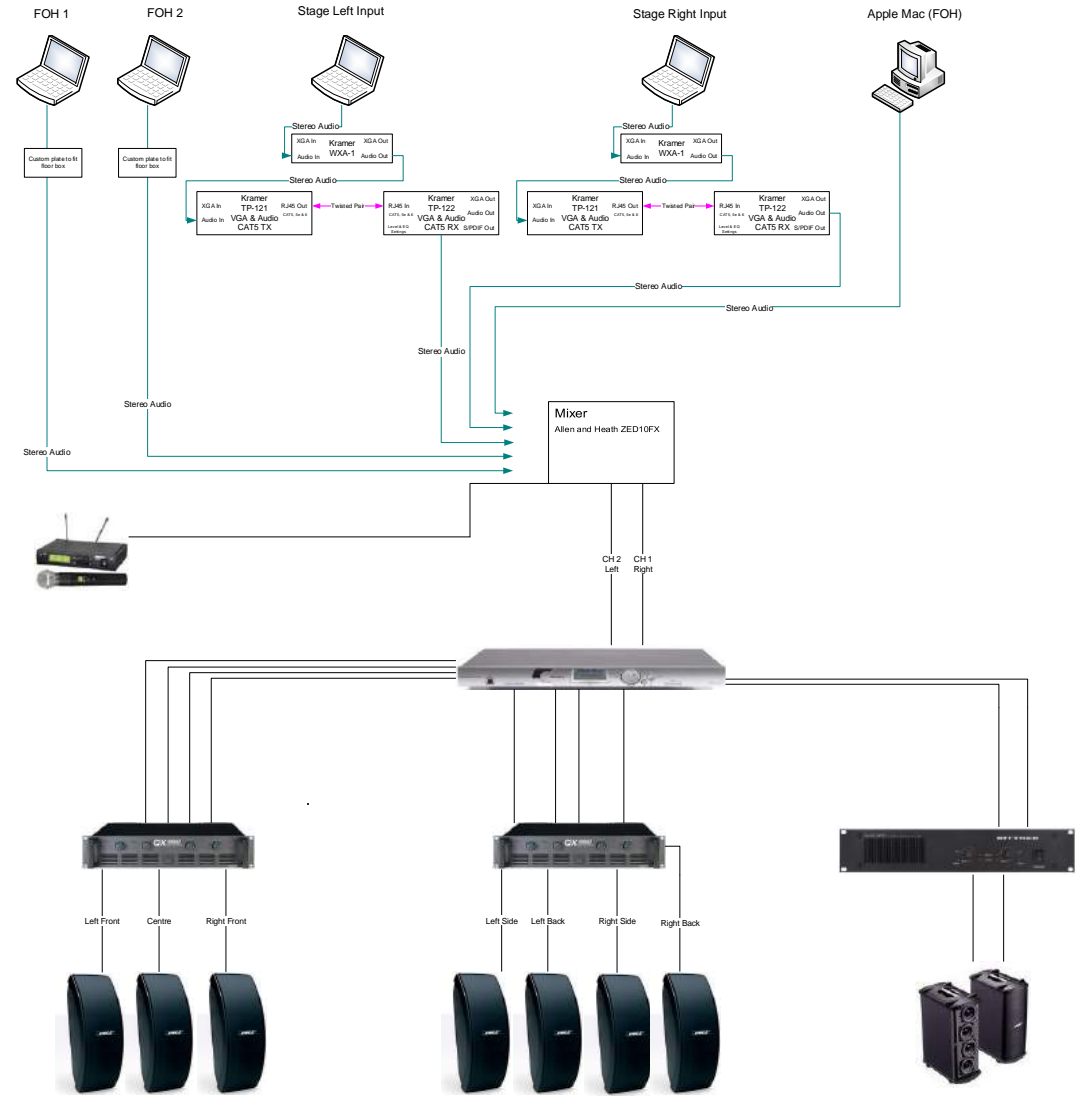

Lighting Layout

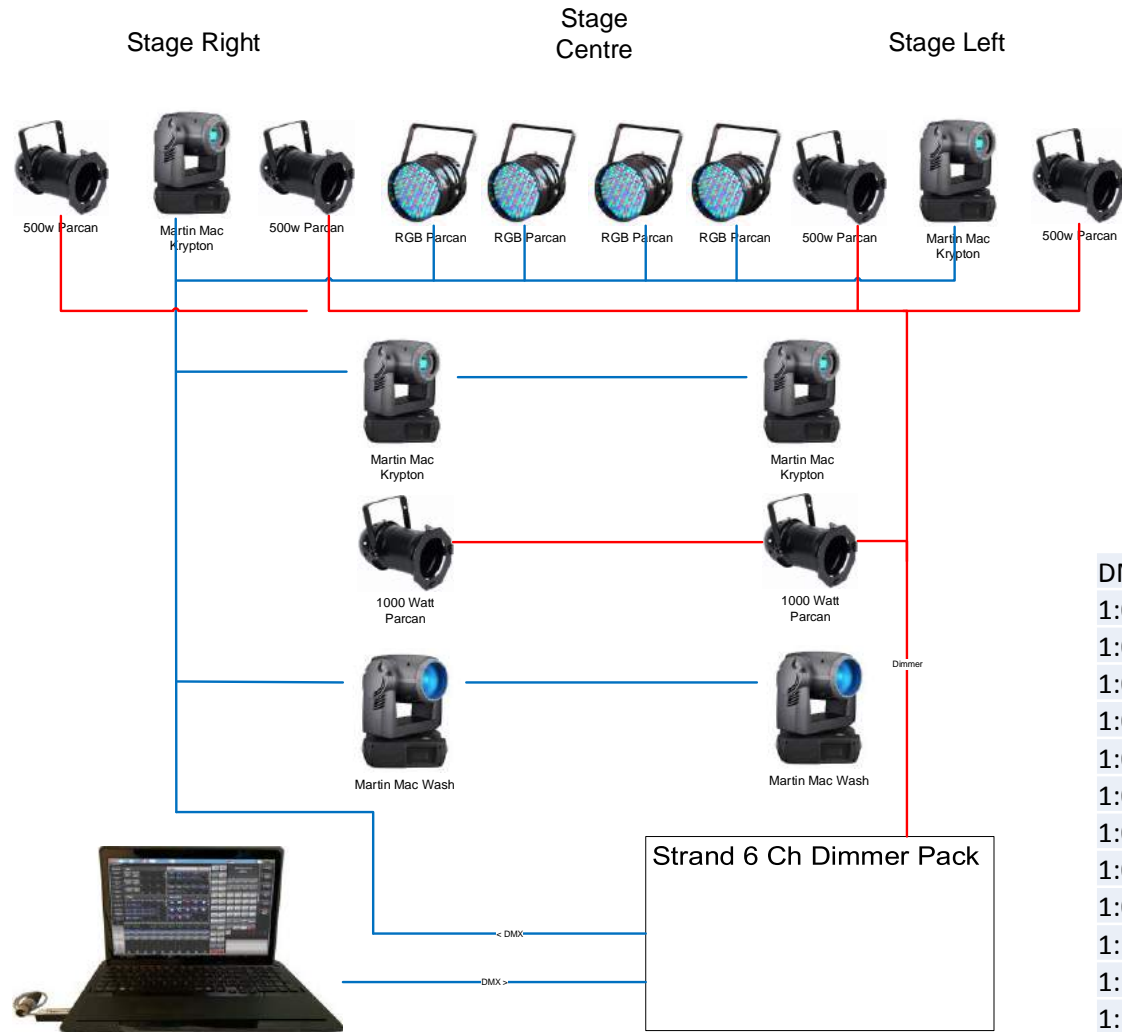

DMX Address		Fixture type	
1:001-006	1 to 6	Generic DMX Dimmer 6 Channel	Dim
1:007-012	7 to 12	Generic DMX Dimmer 6 Channel	
1:013-025	13 to 25	Martin MAC 250 Wash 16 Bit	Right Back Wash
1:026-038	26 to 38	Martin MAC 250 Wash 16 Bit	Left Back Wash
1:039-052	39 to 52	Martin MAC 250 Krypton 16 Bit	Right Middle Krypton
1:053-066	53 to 66	Martin MAC 250 Krypton 16 Bit	Stage Left Krypton
1:067-080	67 to 80	Martin MAC 250 Krypton 16 Bit	Left Middle Krypton
1:081-094	81 to 94	Martin MAC 250 Krypton 16 Bit	Stage Right Krypton
1:095-099	95 to 99	Generic LED PAR 64	Left
1:101-105	101 to 105	Generic LED PAR 64	Left Centre
1:107-111	107 to 111	Generic LED PAR 64	Right Centre
1:113-117	113 to 117	Generic LED PAR 64	Right

Rack Layout

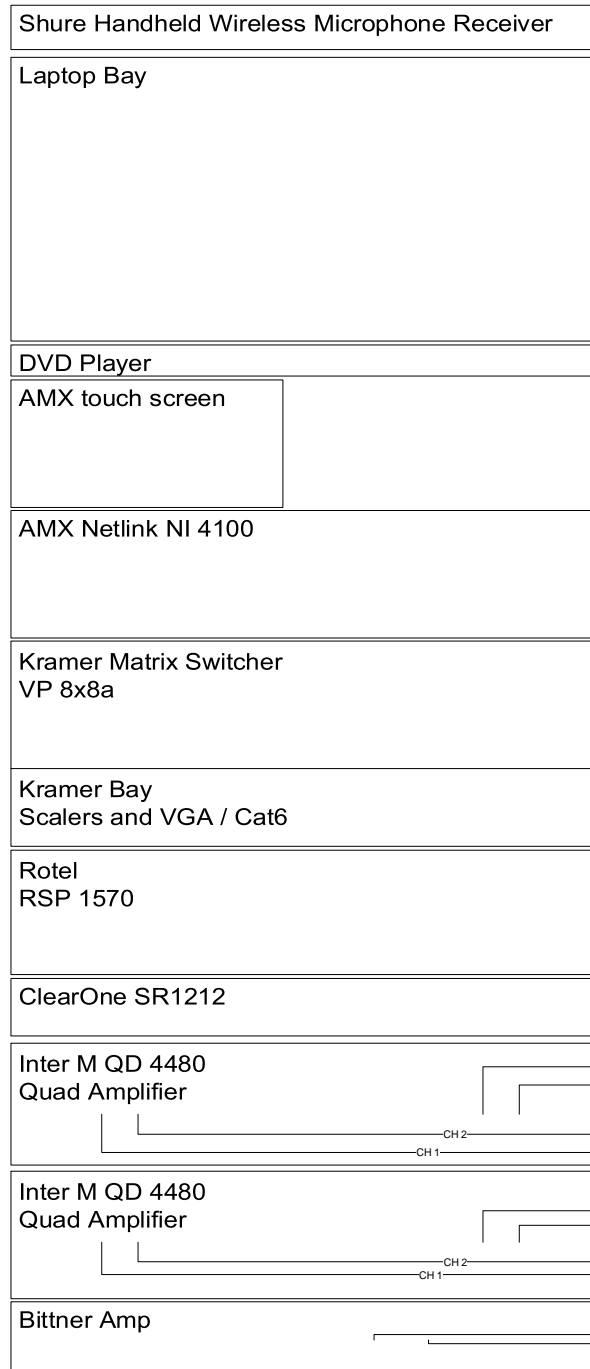

Disconnected by
Dimension Data
NOT USED

CH 3 Centre Front
CH 4 Right Front
CH 2 Not Used
CH 1 Left Front

CH 4 Right Side
CH 3 Right Back
CH 2 Left Side
CH 1 Left Back

Bass Left
Bass Right



NINA VAN DEVENTER
PROPERTY & PROJECT MANAGEMENT