

SuperGrip®

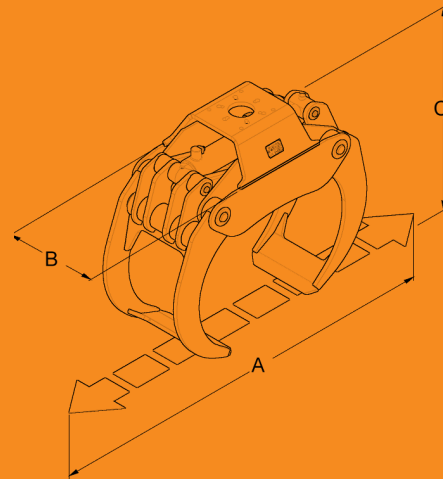

SUPERGRIP S

Features

- Tapered sleeve pin design eliminates any possible joint motion.
- Cushioned cylinders to reduce shock loads.
- Dual solid push rods for balanced design.
- Grapple saw option available on all models.

			260S		300S		360S		420S		520S	
Weight	lb (kg)		514	(233)	518	(235)	838	(380)	898	(408)	1041	(473)
Max. load	lb (kg)		9 900	(4 500)	9 900	(4 500)	17 600	(8 000)	17 600	(8 000)	17 600	(8 000)
Gripping area, tip-tip	ft ² (m ²)		2.80	(0.26)	3.23	(0.30)	3.87	(0.36)	4.52	(0.42)	5.59	(0.52)
Gripping area, practical	ft ² (m ²)		3.77	(0.35)	4.31	(0.40)	4.84	(0.45)	5.28	(0.49)	6.67	(0.62)
Max. gripping width "A"	inches (mm)		60.0	(1 525)	58.3	(1 480)	73.6	(1 870)	79.0	(2 011)	89.1	(2 279)
Overall grapple width "B"	inches (mm)		17.0	(430)	17.0	(430)	20.5	(522)	20.2	(514)	20.5	(514)
Height, arms tip-tip "C"	inches (mm)		34.2	(867)	32.9	(836)	39.3	(998)	42.2	(1 071)	45.3	(1 152)
Max. height arms open	inches (mm)		29.9	(760)	31.7	(804)	31.5	(800)	34.9	(889)	34.6	(886)
Min. height arms closed	inches (mm)		21.7	(550)	22.0	(560)	25.8	(656)	28.0	(714)	29.6	(753)
Grapple jaw width	inches (mm)		15.1	(384)	15.1	(384)	18.1	(460)	18.9	(468)	19.1	(484)
Min. gripping diameter	inches (mm)		3.5	(90)	3.6	(91)	4.3	(110)	4.8	(122)	6.7	(170)
Volume capacity 8 ft wood	cords		0.23		0.27		0.30		0.37		0.42	
Gripping force, arms open, at 3625 psi	lbf (kN)		2451	(10.9)	2338	(10.4)	4161	(18.5)	4363	(19.4)	4701	(20.9)
Gripping force, arms tip-tip, at 3625 psi	lbf (kN)		3396	(15.1)	3282	(14.6)	4319	(19.2)	4498	(20.0)	5196	(23.1)
Opening time, at 50 l/min	s		0.9		0.9		1.6		2.1		2.2	
Closing time, at 50 l/min	s		1.7		1.7		2.6		3.5		3.7	
Max. operating pressure	psi (MPa)		3625	(25)	3625	(25)	3625	(25)	3625	(25)	3625	(25)



info@hultdins.com
hultdins.com

Sales office, North America
Telephone: (519) 754-0044
Fax: (519) 754-1569

Address:
Hultdins Inc, 22 Morton Avenue East
Brantford, Ontario, Canada N3R7J7