

**SuperLine**  
**Product / Manual Catalog**

**SuperLine**  
**Product / Manual Catalog**  
**2017**

**Dentium**  
For Dentists By Dentists

Specifications are subject to change without any notice.  
Some products listed in this catalog are not available in the market due to pending approval.

HEAD OFFICE  
10F, 21, Teheran-ro 87-gil, Gangnam-gu, Seoul, Korea Tel +82-2-555-3750 Fax +82-2-501-9560

HOME PAGE  
[www.dentium.com](http://www.dentium.com)

SPMC-1706 [Rev.1]

**Dentium**  
For Dentists By Dentists

# Contents

<b>SuperLine</b>	SuperLine Characteristics	04	<b>Instruments</b>	Surgical Kit (Full)	38
	SuperLine Fixture Specifications	05		Surgical Kit (Standard)	39
	SuperLine Fixture	06		Surgical Kit (Short Implant)	40
<b>Surgical Components</b>	Cover Screw	07	Drill Stopper Kit	41	
	GBR Healing Abutment	07	Surgical Instruments	42	
	Healing Abutment	08	DASK	50	
<b>Prosthetic Procedure 1</b>	Dual / Combi Abutment - Abutment Level Impression	10	Sinus Bur Kit	51	
	Combi Abutment	11	Sinus Kit	52	
	Dual Abutment	12	DASK / Sinus Bur Kit / TN Brush	53	
	Abutment Level Impression Components	14	Osteotome Kit	54	
	Restorative Kit	15	Trephine Kit	55	
			Prosthetic Kit	56	
<b>Prosthetic Procedure 2</b>	Dual / Custom / Milling / Angled / Direct-Casting / Metal-Casting /		Planning Kit	57	
	Temporary (Plastic & Ti) Abutment - Fixture Level Impression	16	Prosthetic and Laboratory Instrument	58	
	Fixture Level Impression Components	17	Help Kit	59	
	Custom Abutment	19	Polymer Guide Kit	60	
	Milling Abutment	20	<b>New</b> Sinus Kit	61	
	Angled Abutment	22	Ridge Expander Kit	62	
	Direct-Casting Abutment	24	Implant Guide Kit	63	
	Metal-Casting Abutment	24	Digital Full Kit	64	
	Ti-Temporary Abutment	25	Digital Simple Kit	65	
	Plastic Temporary Abutment	25			
<b>Prosthetic Procedure 3</b>	Screw Abutment - Abutment Level Impression	26	Surgical Manual	67	
	Screw Abutment	27	Prosthesis Manual	77	
	Angled Screw Abutment	28			
	Screw Abutment Impression Components	29			
<b>Prosthetic Procedure 4</b>	Overdenture Procedure - Positioner / Mini Ball / Magnetic Attachment	32			
	Positioner	33			
	Mini Ball Attachment	35			
	Magnetic Attachment	36			





## S.L.A. Surface

S.L.A. (Sandblasting with Large grits and Acid etching)

- Higher bone-to-implant contact
- Faster bone formation on the surface

*reference: Kim H., et. al. "The Biocompatibility of SLA-treated Titanium Implants" Biomed. Mater. 2008; 3(2):025011*

*In vivo test*

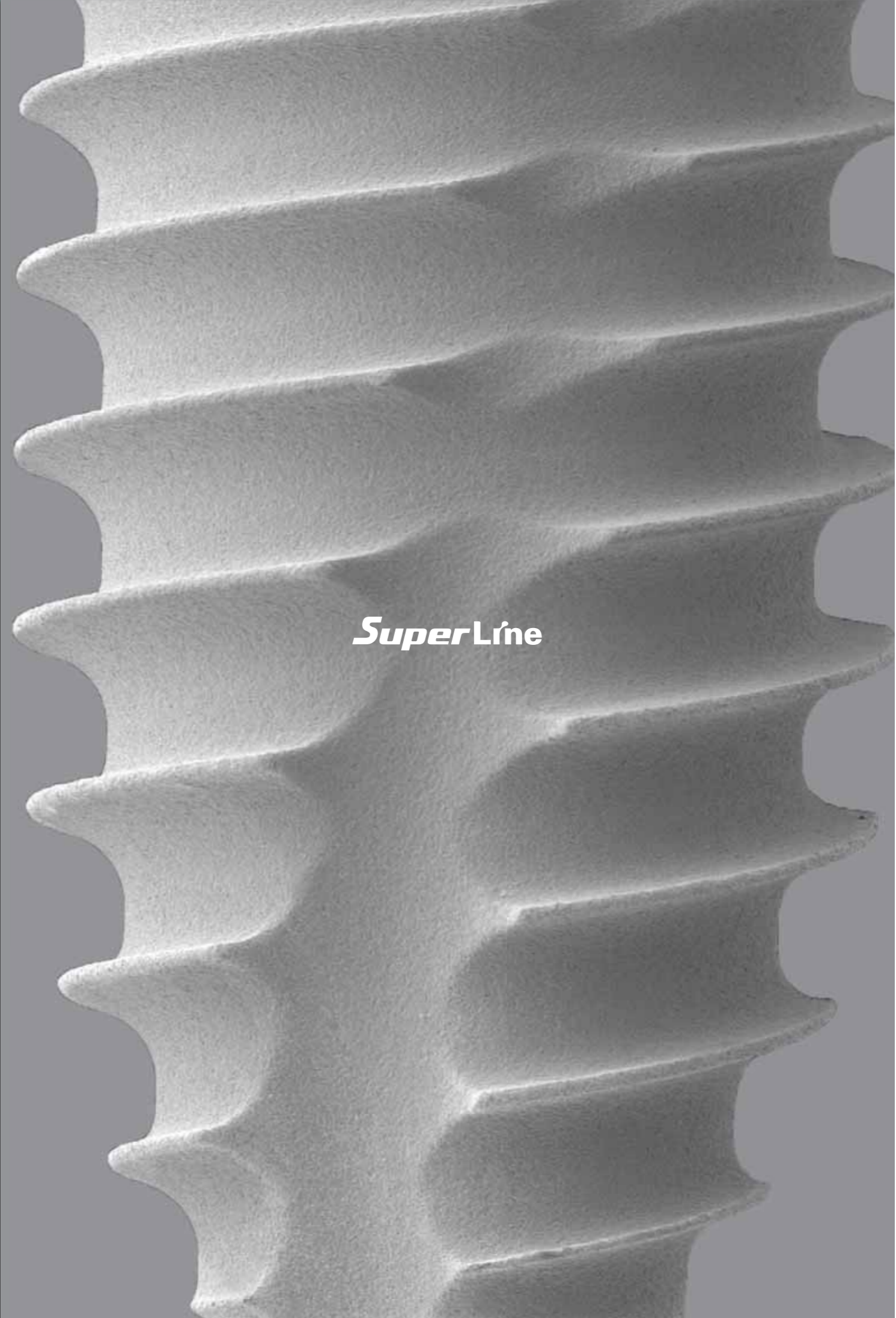

***SuperLine***

# SuperLine Characteristics

## Joint stability & Improved strength for zirconia crown

· Abutment material: Grade 4  $\rightarrow$  Alloy

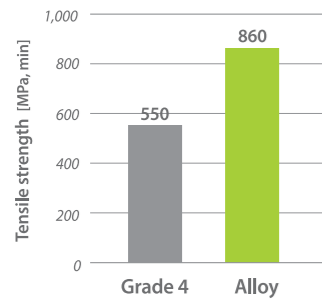

· Long hex design: Improved recognition

## Improved soft tissue management

- Concave abutment design
- Non-coating

## Improved wall thickness

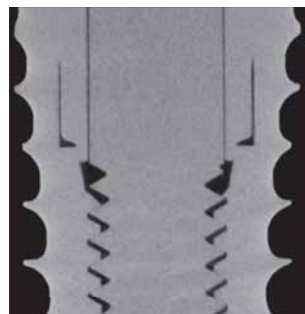

## Double thread & Tapered design



Double threaded tapered body design may provide good success rate in immediate loading cases.

reference: Kim et. al., "A Prospective, 1-year observational study of double-threaded tapered body dental implants with immediate loading" J Prosthet Dent 2015;114:46-51

## Increased thread height and sharper



# SuperLine Fixture Specifications

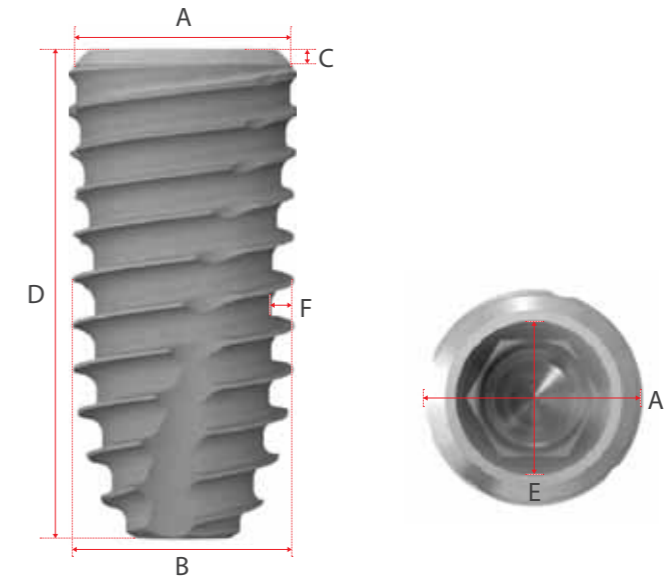

Fixture (Mount Free)								
<b>A</b>	Platform Diameter(Ø)	3.6	4.0	4.4	4.9	6.0	7.0	
<b>B</b>	Body Diameter(Ø)	3.6	4.0	4.5	5.0	5.0	5.8	
<b>C</b>	Bevel Height (mm)	<b>L: 7</b>	1.5	1.5	1.5	1.5	1.5	1.5
		<b>L: 8, 10, 12, 14</b>	0	0.1	0.3	0.4	0.7	1.0
<b>D</b>	Total Length(mm)	7, 8, 10, 12, 14						
<b>E</b>	Abutment Interface(Ø)	3.33	3.33	3.33	3.33	3.33	3.33	
<b>F</b>	Thread Depth(mm)	0.38	0.40	0.45	0.50	0.55	0.60	
Cap Color								
		Yellow	Green	Blue	Red	Orange	Violet	
Selection Guideline		Anterior	Anterior	Premolar	Molar	Molar	Molar	

# SuperLine Fixture

· Cover screw is not included in the package

Platform	Body	L	Art. No.
Ø 3.6	Ø 3.6	7	FX 36 07 SW
		8	FX 36 08 SW
		10	FX 36 10 SW
		12	FX 36 12 SW
		14	FX 36 14 SW
Ø 4.0	Ø 4.0	7	FX 40 07 SW
		8	FX 40 08 SW
		10	FX 40 10 SW
		12	FX 40 12 SW
		14	FX 40 14 SW
Ø 4.4	Ø 4.5	7	FX 45 07 SW
		8	FX 45 08 SW
		10	FX 45 10 SW
		12	FX 45 12 SW
		14	FX 45 14 SW
Ø 4.9	Ø 5.0	7	FX 50 07 SW
		8	FX 50 08 SW
		10	FX 50 10 SW
		12	FX 50 12 SW
		14	FX 50 14 SW
Ø 6.0	Ø 5.0	7	FX 60 07 SW
		8	FX 60 08 SW
		10	FX 60 10 SW
		12	FX 60 12 SW
		Ø 7.0	Ø 5.8
8	FX 70 08 SW		
10	FX 70 10 SW		
12	FX 70 12 SW		

Unit: mm, Scale 1.5 : 1

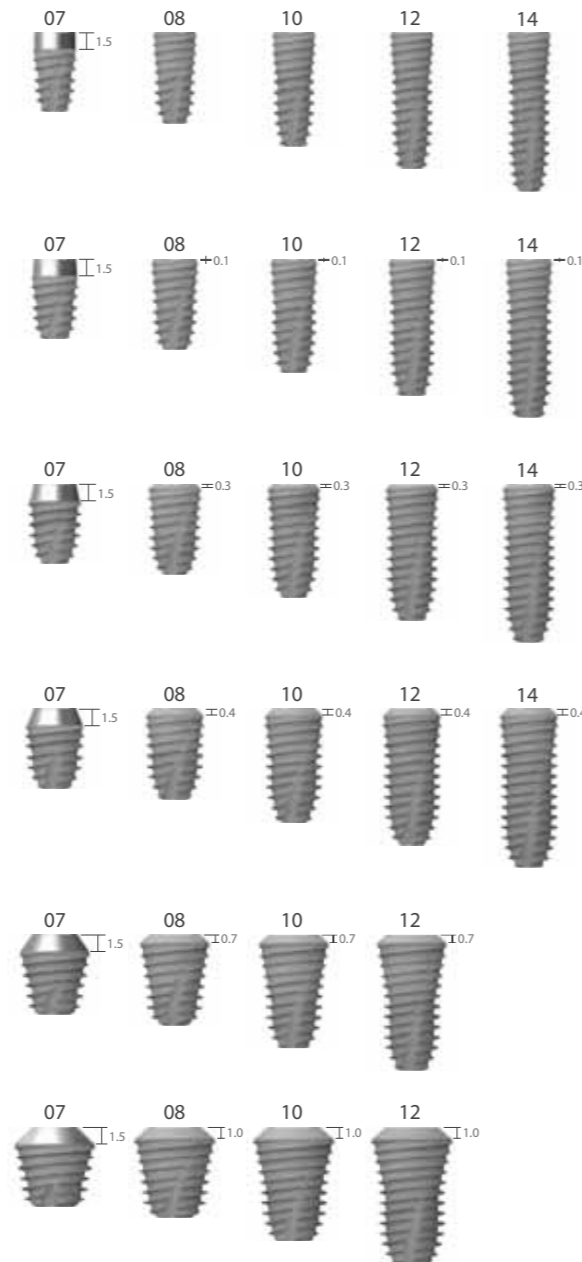

# Cover Screw

Unit: mm, Scale 1.5 : 1

- Single use only
- Must sterilize prior to use

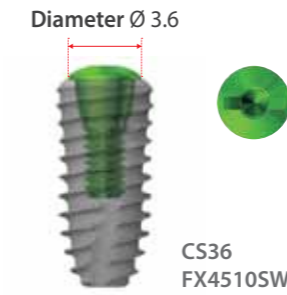

Color	Diameter	Art. No.
Green	Ø 3.6	CS 36

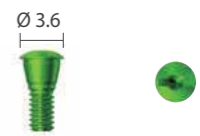

Hex driver: Use no more than 5N-cm of torque when screwing a cover screw to a fixture.  
If hex is worn, slot on the head of the product can be used to rotate it.

# GBR Healing Abutment

Unit: mm, Scale 1.5 : 1

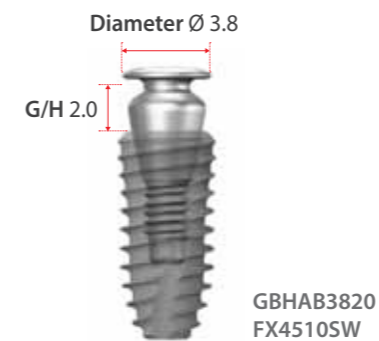

Diameter	G/H	Art. No.
Ø 3.3	3.5	GBHAB 33 35
Ø 3.8	0.5	GBHAB 38 05
Ø 3.8	2.0	GBHAB 38 20



Hex driver: Use no more than 10N-cm of torque when screwing a healing abutment to a fixture.  
If hex is worn, slot on the head of the product can be used to rotate it.

Note: To prevent damage to the Implant driver or fixture, do not over torque during fixture insertion.

# Healing Abutment

Unit: mm, Scale 1.5 : 1



Diameter	G/H	H	Art. No.
Ø 4.0	2.0	2.0	HAB 40 20 20 E
	2.0	3.5	HAB 40 20 35 E
	3.0	5.0	HAB 40 30 50 E
	4.0	7.0	HAB 40 40 70 E
Ø 4.5	2.0	2.0	HAB 45 20 20 E
	2.0	3.5	HAB 45 20 35 E
	3.0	5.0	HAB 45 30 50 E
	4.0	7.0	HAB 45 40 70 E
Ø 5.5	2.0	2.0	HAB 55 20 20 E
	2.0	3.5	HAB 55 20 35 E
	3.0	5.0	HAB 55 30 50 E
	4.0	7.0	HAB 55 40 70 E
Ø 6.5	2.0	2.0	HAB 65 20 20 E
	2.0	3.5	HAB 65 20 35 E
	3.0	5.0	HAB 65 30 50 E
	4.0	7.0	HAB 65 40 70 E

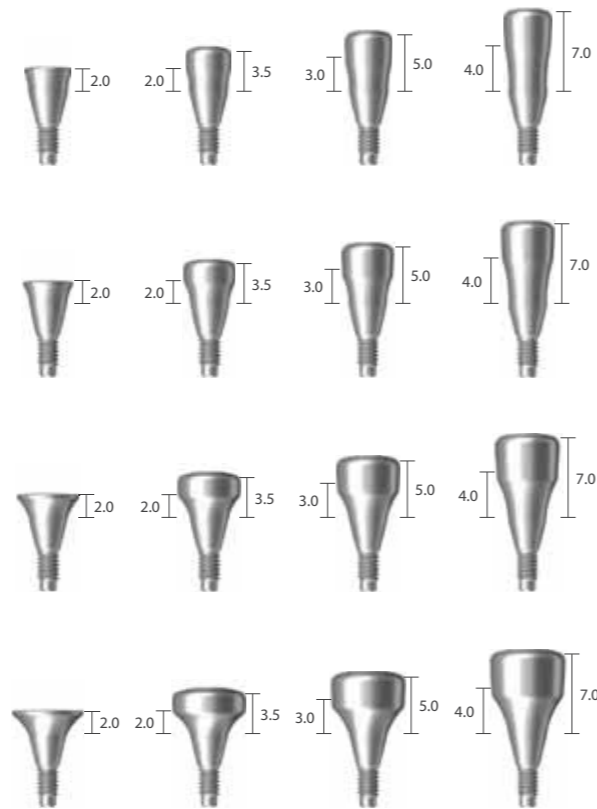

Hex driver: Use no more than 10N-cm of torque when screwing a healing abutment to a fixture.  
If hex is worn, slot on the head of the product can be used to rotate it.

# Healing Abutment

Unit: mm, Scale 1.5 : 1

Diameter	G/H	H	Art. No.
Ø 7.5	2.0	3.5	HAB 75 20 35 E
	3.0	5.0	HAB 75 30 50 E
Ø 8.5	2.0	3.5	HAB 85 20 35 E
	3.0	5.0	HAB 85 30 50 E
Ø 9.5	2.0	3.5	HAB 95 20 35 E
	3.0	5.0	HAB 95 30 50 E

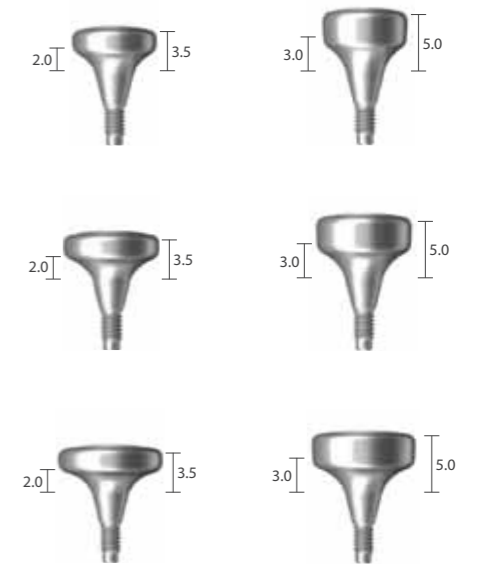

Hex driver: Use no more than 10N-cm of torque when screwing a healing abutment to a fixture.  
If hex is worn, slot on the head of the product can be used to rotate it.

# Prosthetic Procedure 1

Impression Technique and Restoration Selection

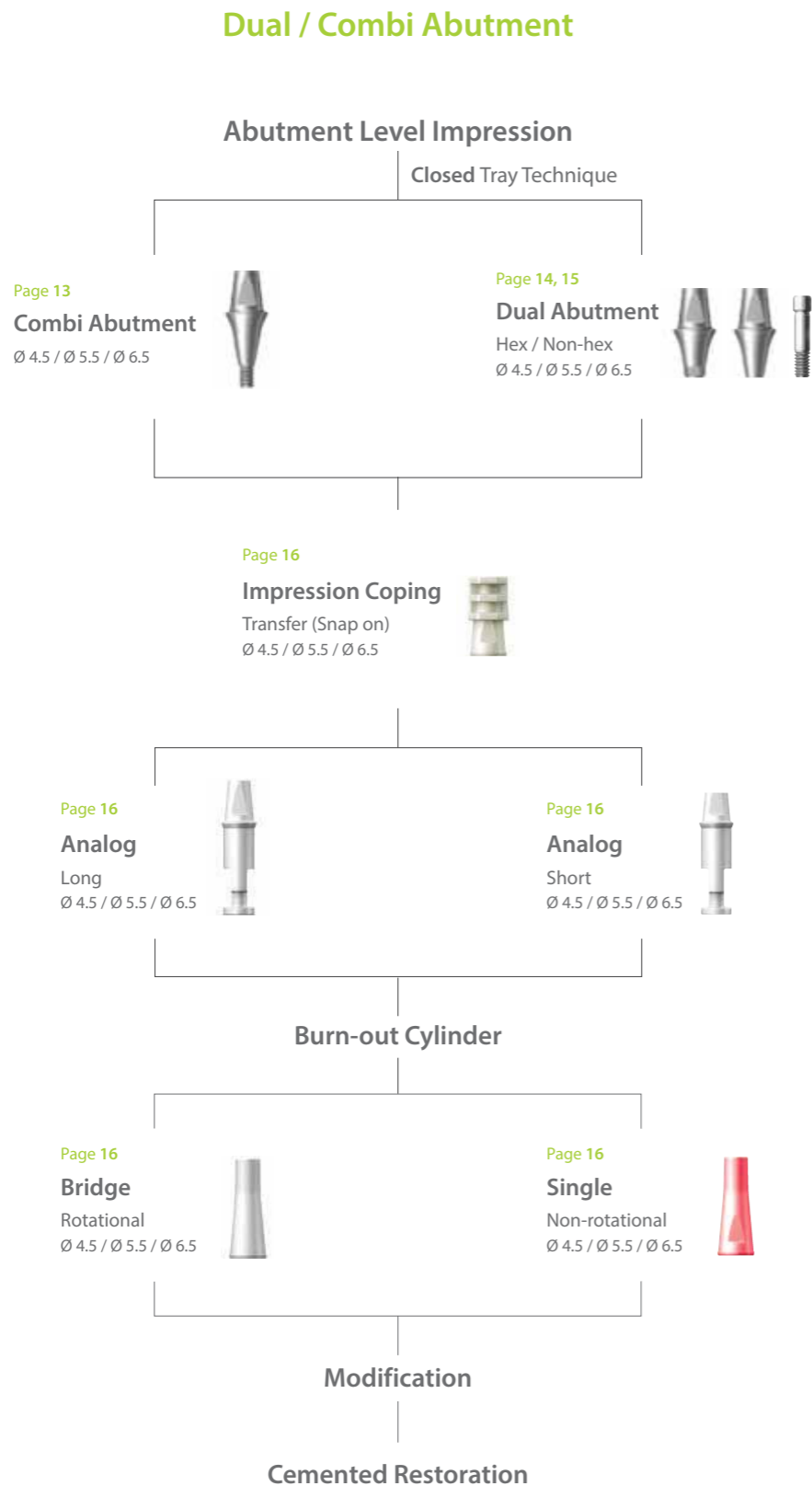

# Combi Abutment

Unit: mm, Scale 1 : 1

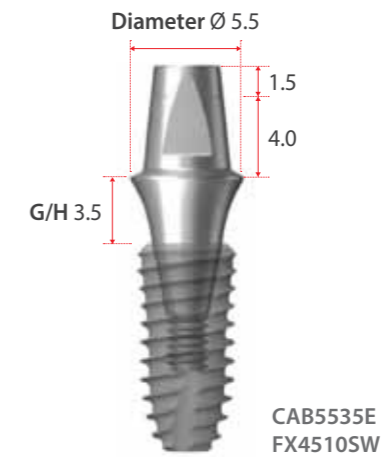

Diameter	G/H	Type	Art. No.	Type	Art. No.
Ø 4.5	1.0	Short	CAB 45 10 SE	Long	CAB 45 10 E
	1.5		CAB 45 15 SE		CAB 45 15 E
	2.5		CAB 45 25 SE		CAB 45 25 E
	3.5		CAB 45 35 SE		CAB 45 35 E
	4.5		CAB 45 45 SE		CAB 45 45 E
	5.5		CAB 45 55 SE		CAB 45 55 E

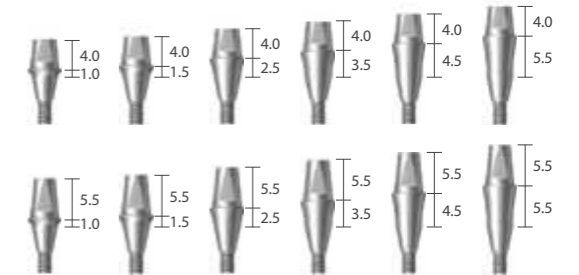

Ø 5.5	1.5	Short	CAB 55 15 SE	Long	CAB 55 15 E
	2.5		CAB 55 25 SE		CAB 55 25 E
	3.5		CAB 55 35 SE		CAB 55 35 E
	4.5		CAB 55 45 SE		CAB 55 45 E
	5.5		CAB 55 55 SE		CAB 55 55 E

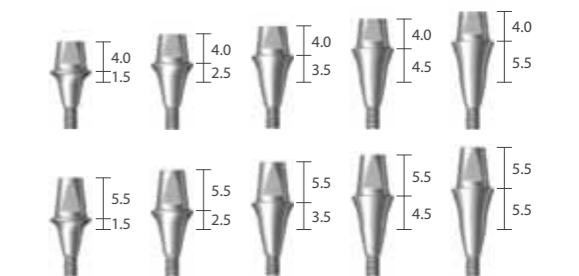

Ø 6.5	1.5	Short	CAB 65 15 SE	Long	CAB 65 15 E
	2.5		CAB 65 25 SE		CAB 65 25 E
	3.5		CAB 65 35 SE		CAB 65 35 E
	4.5		CAB 65 45 SE		CAB 65 45 E
	5.5		CAB 65 55 SE		CAB 65 55 E

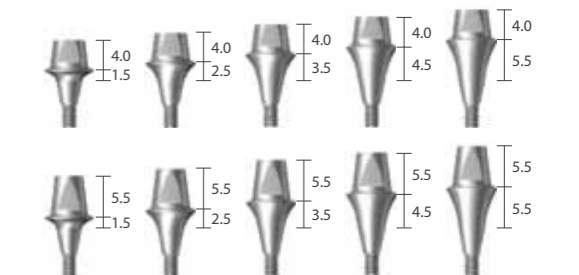

Note: It is recommended to keep the torque level at 25~30 N·cm to tighten the combi abutment with fixture.

# Dual Abutment\_Hex

Unit: mm, Scale 1.5 : 1

· Abutment screw is included

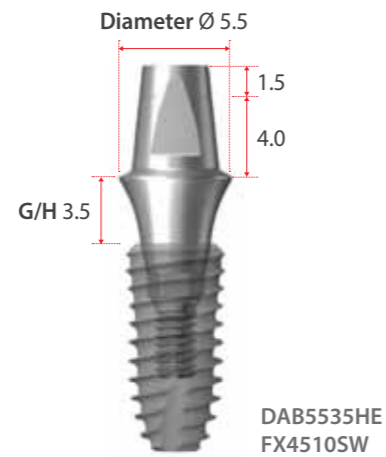

DAB5535HE  
FX4510SW

Diameter	G/H	Art. No.
Ø 4.5	1.0	DAB 45 10 HE
	1.5	DAB 45 15 HE
	2.5	DAB 45 25 HE
	3.5	DAB 45 35 HE
	4.5	DAB 45 45 HE
	5.5	DAB 45 55 HE
Ø 5.5	1.5	DAB 55 15 HE
	2.5	DAB 55 25 HE
	3.5	DAB 55 35 HE
	4.5	DAB 55 45 HE
	5.5	DAB 55 55 HE
Ø 6.5	1.5	DAB 65 15 HE
	2.5	DAB 65 25 HE
	3.5	DAB 65 35 HE
	4.5	DAB 65 45 HE
	5.5	DAB 65 55 HE

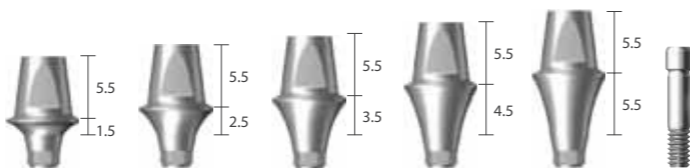
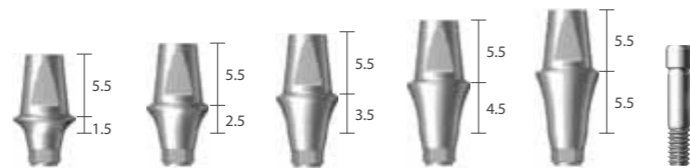
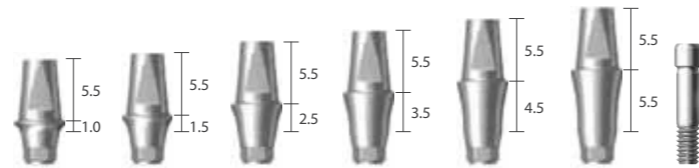

Note: It is recommended to keep the torque level at 25~30 N·cm to tighten the dual abutment with fixture.

# Dual Abutment\_Non-hex

Unit: mm, Scale 1.5 : 1

· Abutment screw is included

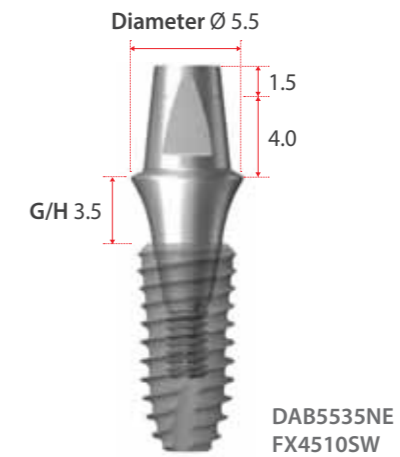

DAB5535NE  
FX4510SW

Diameter	G/H	Art. No.
Ø 4.5	1.0	DAB 45 10 NE
	1.5	DAB 45 15 NE
	2.5	DAB 45 25 NE
	3.5	DAB 45 35 NE
	4.5	DAB 45 45 NE
	5.5	DAB 45 55 NE
Ø 5.5	1.5	DAB 55 15 NE
	2.5	DAB 55 25 NE
	3.5	DAB 55 35 NE
	4.5	DAB 55 45 NE
	5.5	DAB 55 55 NE
Ø 6.5	1.5	DAB 65 15 NE
	2.5	DAB 65 25 NE
	3.5	DAB 65 35 NE
	4.5	DAB 65 45 NE
	5.5	DAB 65 55 NE

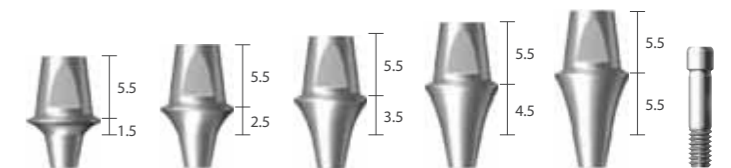
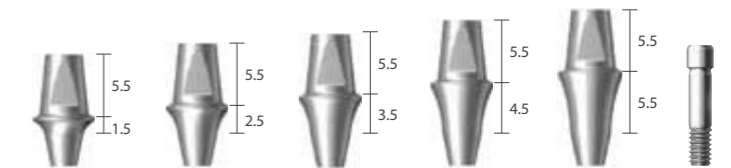
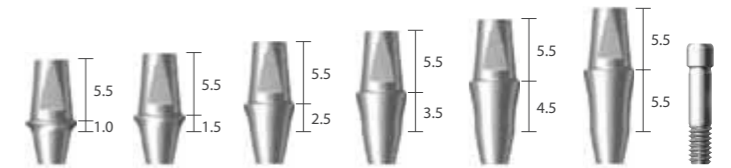

Note: It is recommended to keep the torque level at 25~30 N·cm to tighten the dual abutment with fixture.



# Abutment Level Impression Components

Unit: mm, Scale 1 : 1

## Comfort Cap | Snap on

Type	Diameter	Art. No.
Short	Ø 4.5	CCC 45 CS
	Ø 5.5	CCC 55 CS
	Ø 6.5	CCC 65 CS
Long	Ø 4.5	CCC 45 C
	Ø 5.5	CCC 55 C
	Ø 6.5	CCC 65 C



## Impression Coping

Diameter	Art. No.
Ø 4.5	CIC 45 L
Ø 5.5	CIC 55 L
Ø 6.5	CIC 65 L



## Lab Analog

Type	Diameter	Art. No.
Short	Ø 4.5	CAN 45 SL
	Ø 5.5	CAN 55 SL
	Ø 6.5	CAN 65 SL
Long	Ø 4.5	CAN 45 LL
	Ø 5.5	CAN 55 LL
	Ø 6.5	CAN 65 LL

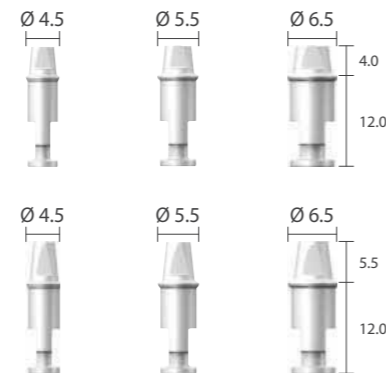

## Burn-out Cylinder

Type	Diameter	Art. No.
Single	Ø 4.5	CBC 45 SL
	Ø 5.5	CBC 55 SL
	Ø 6.5	CBC 65 SL
Bridge	Ø 4.5	CBC 45 BL
	Ø 5.5	CBC 55 BL
	Ø 6.5	CBC 65 BL

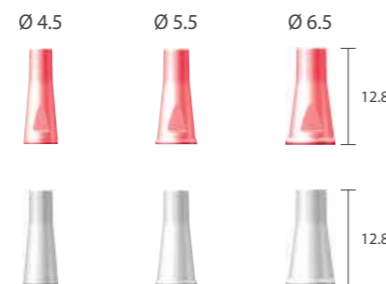

# Restorative Kit

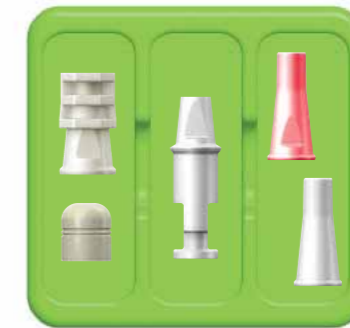

## Combi & Dual Abutment

Art. No	Lab. Components				
	Comfort Cap	Impression Coping	Analog	Burn-out Cylinder	
XSDAB 45 S XSDAB 45	CCC 45 CS CCC 45 C	CIC 45 L	CAN 45 SL CAN 45 LL	CBC 45 SL	CBC 45 BL
XSDAB 55 S XSDAB 55	CCC 55 CS CCC 55 C	CIC 55 L	CAN 55 SL CAN 55 LL	CBC 55 SL	CBC 55 BL
XSDAB 65 S XSDAB 65	CCC 65 CS CCC 65 C	CIC 65 L	CAN 65 SL CAN 65 LL	CBC 65 SL	CBC 65 BL

# Prosthetic Procedure 2

Impression Technique and Restoration Selection

Dual / Custom / Milling / Angled / Direct-Casting / Metal-Casting /  
Ti-Temporary / Plastic Temporary Abutment

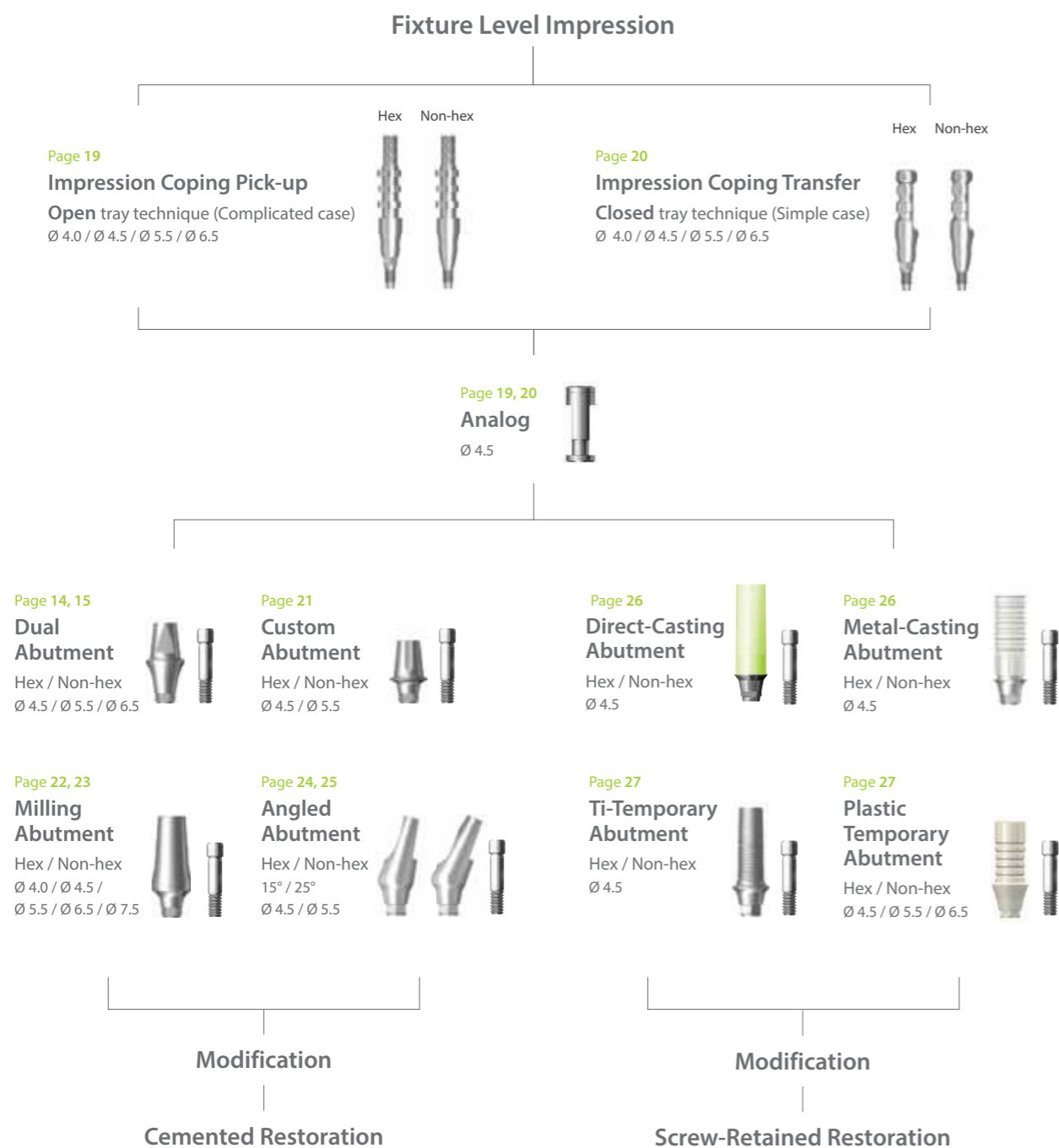

# Fixture Level Impression Components

Unit: mm, Scale 1 : 1

· Impression coping screw is included with Impression coping.

## Impression Coping Pick-up

Diameter	Size	Type	Art. No.
Ø 4.0	Short	Hex	DPU 40 11 HE
	Short	Non-hex	DPU 40 11 NE
	Long	Hex	DPU 40 15 HE
	Long	Non-hex	DPU 40 15 NE

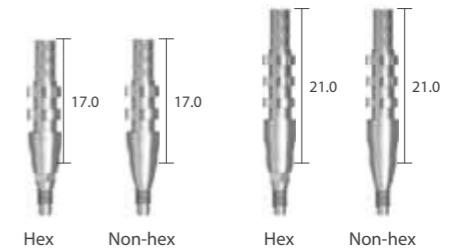

Ø 4.5	Short	Hex	DPU 45 11 HE
	Short	Non-hex	DPU 45 11 NE
	Long	Hex	DPU 45 15 HE
	Long	Non-hex	DPU 45 15 NE

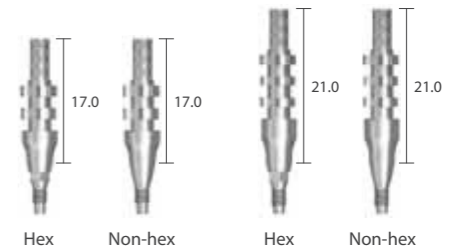

Ø 5.5	Short	Hex	DPU 55 11 HE
	Short	Non-hex	DPU 55 11 NE
	Long	Hex	DPU 55 15 HE
	Long	Non-hex	DPU 55 15 NE

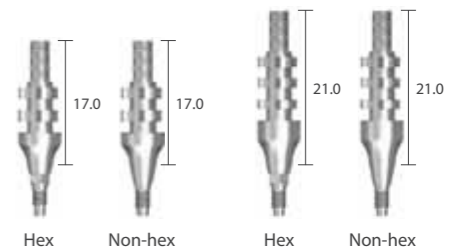

Ø 6.5	Short	Hex	DPU 65 11 HE
	Short	Non-hex	DPU 65 11 NE
	Long	Hex	DPU 65 15 HE
	Long	Non-hex	DPU 65 15 NE

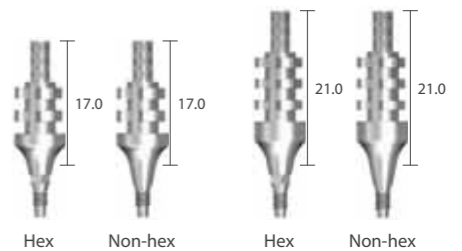

## Impression Coping Transfer Screw

Size	L	Art. No.
Short	23.0	DPS 11 E
Long	27.0	DPS 15 E

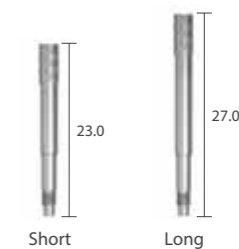

## Analog

Diameter	L	Art. No.
Ø 4.5	12.0	DANSE

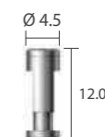

# Fixture Level Impression Components

Unit: mm, Scale 1 : 1

· Impression coping screw is included with Impression coping.

## Impression Coping Transfer

Diameter	Size	Type	Art. No.
Ø 4.0	Short	Hex	DTF 40 11 HE
	Short	Non-hex	DTF 40 11 NE
	Long	Hex	DTF 40 15 HE
	Long	Non-hex	DTF 40 15 NE

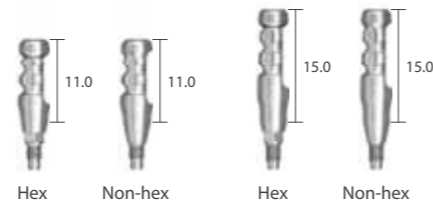

Ø 4.5	Short	Hex	DTF 45 11 HE
	Short	Non-hex	DTF 45 11 NE
	Long	Hex	DTF 45 15 HE
	Long	Non-hex	DTF 45 15 NE

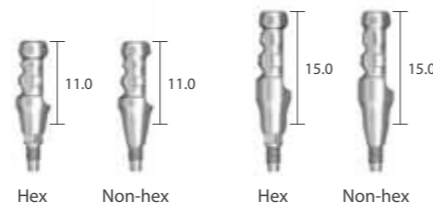

Ø 5.5	Short	Hex	DTF 55 11 HE
	Short	Non-hex	DTF 55 11 NE
	Long	Hex	DTF 55 15 HE
	Long	Non-hex	DTF 55 15 NE

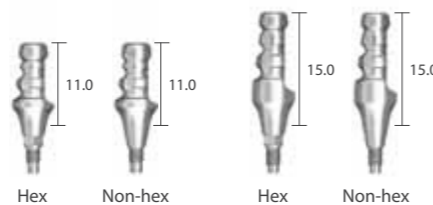

Ø 6.5	Short	Hex	DTF 65 11 HE
	Short	Non-hex	DTF 65 11 NE
	Long	Hex	DTF 65 15 HE
	Long	Non-hex	DTF 65 15 NE

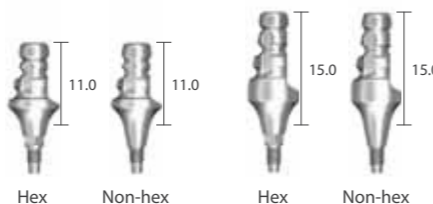

## Impression Coping Transfer Screw

Size	L	Art. No.
Short	17.0	DTS 11 E
Long	21.0	DTS 15 E

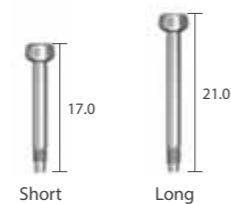

## Analog

Diameter	L	Art. No.
Ø 4.5	12.0	DANSE

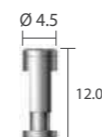

# Custom Abutment

Unit: mm, Scale 1.5 : 1

· Abutment screw is included.

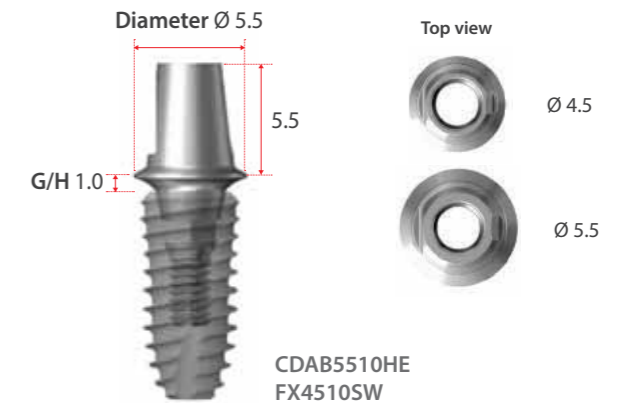

Diameter	G/H	Type	Art. No.
Ø 4.5	0.5	Hex	CDAB 45 05 HE
	0.5	Non-hex	CDAB 45 05 NE
	1.5	Hex	CDAB 45 15 HE
	1.5	Non-hex	CDAB 45 15 NE

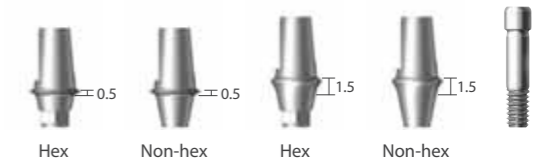

Ø 5.5	1.0	Hex	CDAB 55 10 HE
	1.0	Non-hex	CDAB 55 10 NE
	2.0	Hex	CDAB 55 20 HE
	2.0	Non-hex	CDAB 55 20 NE

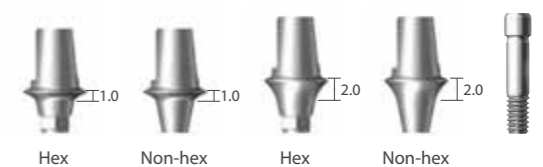

Note: It is recommended to keep the torque level at 25~30 N·cm to tighten the custom abutment with fixture.

# Milling Abutment

Unit: mm, Scale 1.5 : 1

· Abutment screw is included.

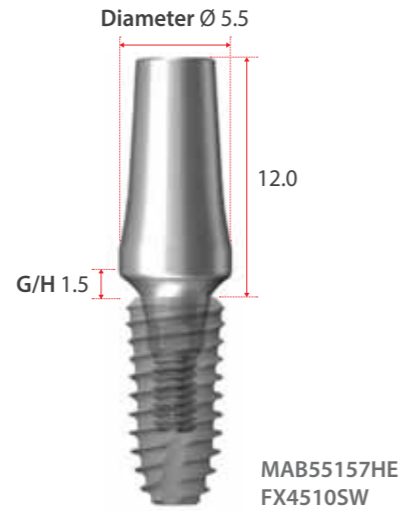

Diameter	G/H	Type	Art. No.
Ø 4.0	1.0	Hex	MAB 40 105 HE
	1.0	Non-hex	MAB 40 105 NE



Diameter	G/H	Type	Art. No.
Ø 4.5	1.5	Hex	MAB 45 156 HE
	1.5	Non-hex	MAB 45 156 NE



Diameter	G/H	Type	Art. No.
Ø 5.5	1.5	Hex	MAB 55 157 HE
	1.5	Non-hex	MAB 55 157 NE
	2.5	Hex	MAB 55 257 HE
	2.5	Non-hex	MAB 55 257 NE

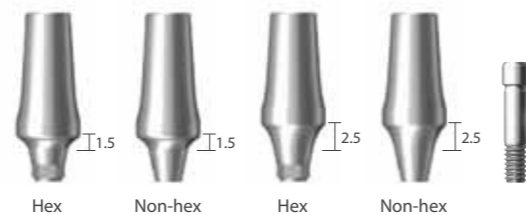

Note: It is recommended to keep the torque level at 25~30 N·cm to tighten the milling abutment with fixture.

# Milling Abutment

Unit: mm, Scale 1.5 : 1

· Abutment screw is included.

Diameter	G/H	Type	Art. No.
Ø 6.5	1.5	Hex	MAB 65 158 HE
	1.5	Non-hex	MAB 65 158 NE
	2.5	Hex	MAB 65 258 HE
	2.5	Non-hex	MAB 65 258 NE
	3.5	Hex	MAB 65 358 HE
	3.5	Non-hex	MAB 65 358 NE

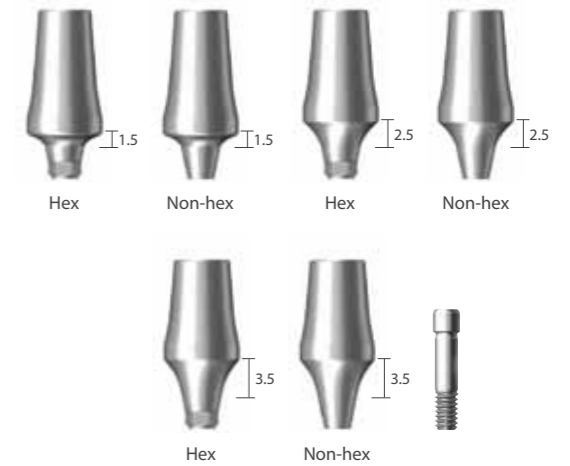

Diameter	G/H	Type	Art. No.
Ø 7.5	2.5	Hex	MAB 75 259 HE
	2.5	Non-hex	MAB 75 259 NE
	3.5	Hex	MAB 75 359 HE
	3.5	Non-hex	MAB 75 359 NE



Note: It is recommended to keep the torque level at 25~30 N·cm to tighten the milling abutment with fixture.

# Angled Abutment\_15°

Unit: mm, Scale 1.5 : 1

· Abutment screw is included.

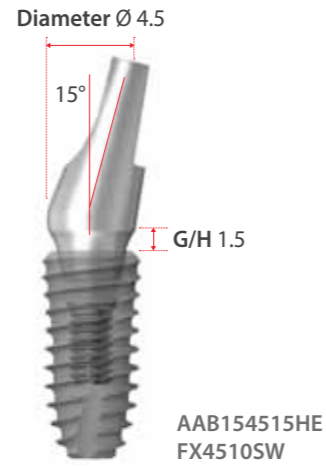

Diameter	G/H	Type	Art. No.
Ø 4.5	1.5	Hex	AAB 15 45 15 HE
	1.5	Non-hex	AAB 15 45 15 NE
	2.5	Hex	AAB 15 45 25 HE
	2.5	Non-hex	AAB 15 45 25 NE
	3.5	Hex	AAB 15 45 35 HE
	3.5	Non-hex	AAB 15 45 35 NE

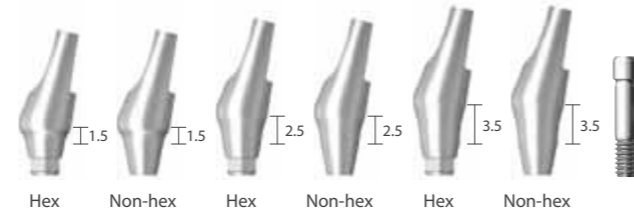

Diameter	G/H	Type	Art. No.
Ø 5.5	1.5	Hex	AAB 15 55 15 HE
	1.5	Non-hex	AAB 15 55 15 NE
	2.5	Hex	AAB 15 55 25 HE
	2.5	Non-hex	AAB 15 55 25 NE
	3.5	Hex	AAB 15 55 35 HE
	3.5	Non-hex	AAB 15 55 35 NE



Note: It is recommended to keep the torque level at 25~30 N·cm to tighten the angled abutment with fixture.

# Angled Abutment\_25°

Unit: mm, Scale 1.5 : 1

· Abutment screw is included.

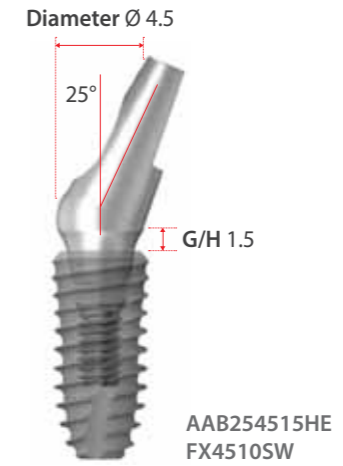

Diameter	G/H	Type	Art. No.
Ø 4.5	1.5	Hex	AAB 25 45 15 HE
	1.5	Non-hex	AAB 25 45 15 NE
	2.5	Hex	AAB 25 45 25 HE
	2.5	Non-hex	AAB 25 45 25 NE
	3.5	Hex	AAB 25 45 35 HE
	3.5	Non-hex	AAB 25 45 35 NE



Diameter	G/H	Type	Art. No.
Ø 5.5	1.5	Hex	AAB 25 55 15 HE
	1.5	Non-hex	AAB 25 55 15 NE
	2.5	Hex	AAB 25 55 25 HE
	2.5	Non-hex	AAB 25 55 25 NE
	3.5	Hex	AAB 25 55 35 HE
	3.5	Non-hex	AAB 25 55 35 NE



Note: It is recommended to keep the torque level at 25~30 N·cm to tighten the angled abutment with fixture.

# Direct-Casting Abutment

Unit: mm, Scale 1.5 : 1

• Abutment screw is included.

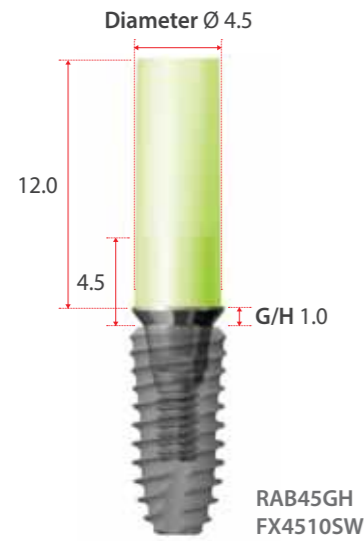

Gold

Diameter	G/H	Type	Art. No.
Ø 4.5	1.0	Hex	RAB 45 GH
		Non-hex	RAB 45 GN



# Ti-Temporary Abutment

Unit: mm, Scale 1.5 : 1

• Abutment screw is included.

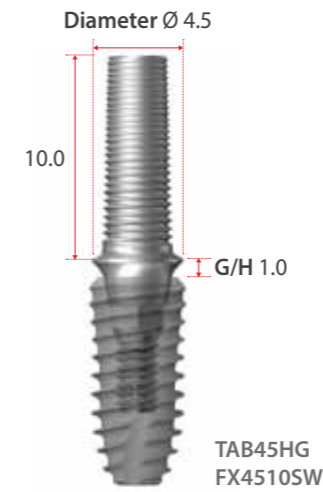

Diameter	G/H	Type	Art. No.
Ø 4.5	1.0	Hex	TAB 45 HG
		Non-hex	TAB 45 NG

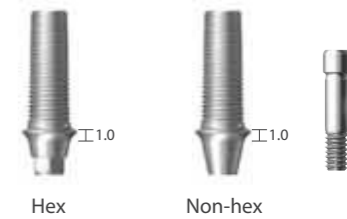

# Metal-Casting Abutment

Unit: mm, Scale 1.5 : 1

• Abutment screw is included.

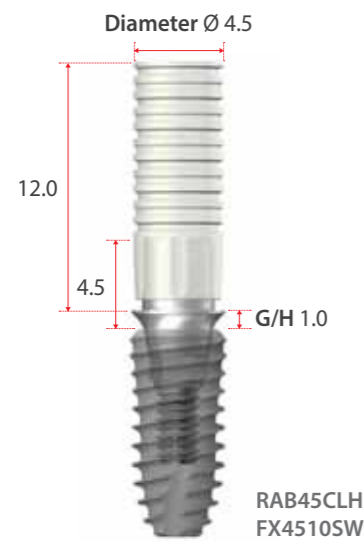

Co-Cr

Diameter	G/H	Type	Art. No.
Ø 4.5	1.0	Hex	RAB 45 CLH
		Non-hex	RAB 45 CLN



# Plastic Temporary Abutment

Unit: mm, Scale 1.5 : 1

• Abutment screw is included.



Diameter	G/H	Type	Art. No.
Ø 4.5	2.0	Hex	RAB 45 20 PHL
		Non-hex	RAB 45 20 PNL
Ø 5.5	2.0	Hex	RAB 55 20 PHL
		Non-hex	RAB 55 20 PNL
Ø 6.5	2.0	Hex	RAB 65 20 PHL
		Non-hex	RAB 65 20 PNL



Note: It is recommended to keep the torque level at 25~30 N-cm to tighten the direct casting/metal casting abutment with fixture.

Note: It is recommended to keep the torque level at 25~30 N-cm to tighten the temporary abutment with fixture.

# Prosthetic Procedure 3

Impression Technique and Restoration Selection

## Screw Abutment

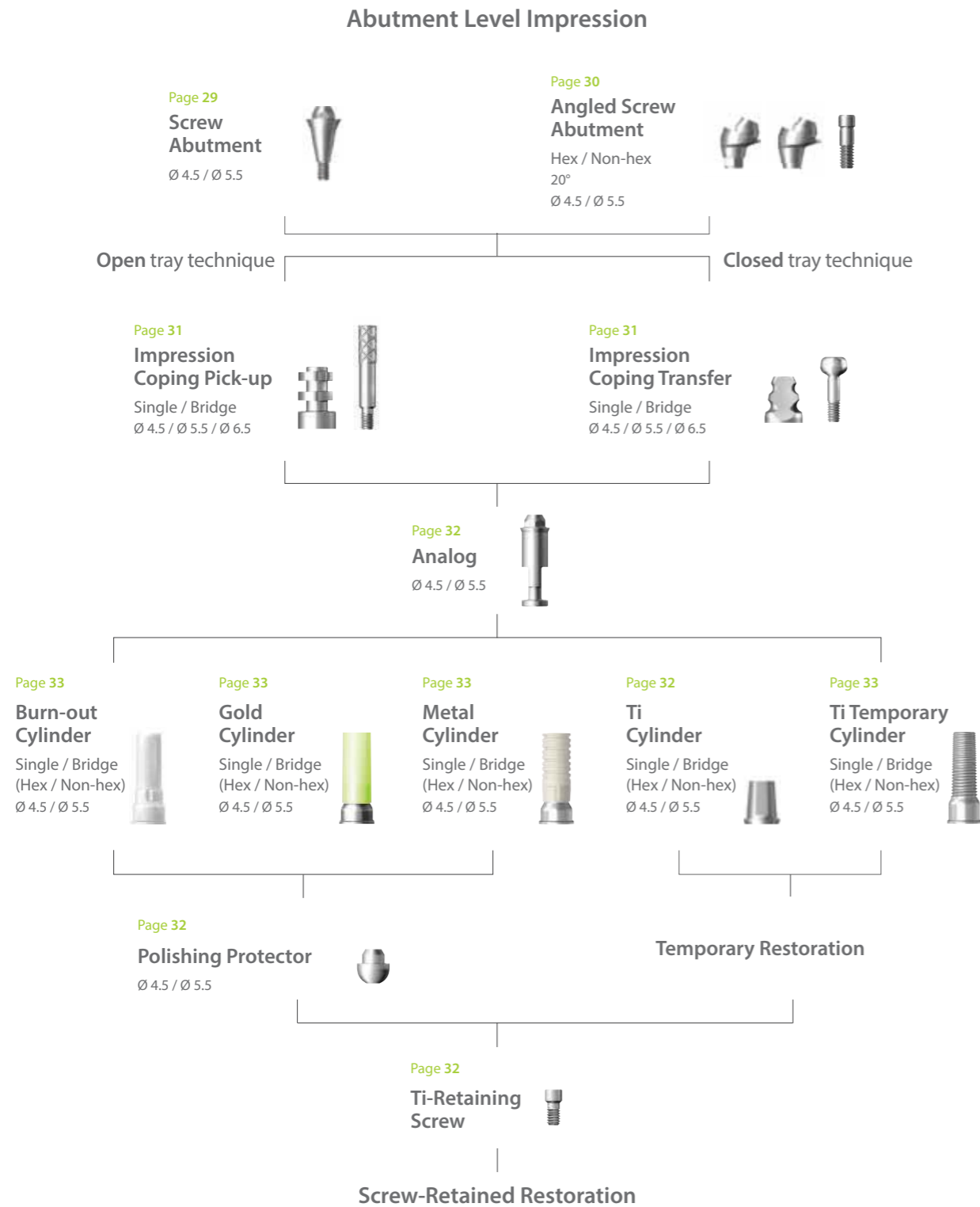

# Screw Abutment

Unit: mm, Scale 1.5 : 1

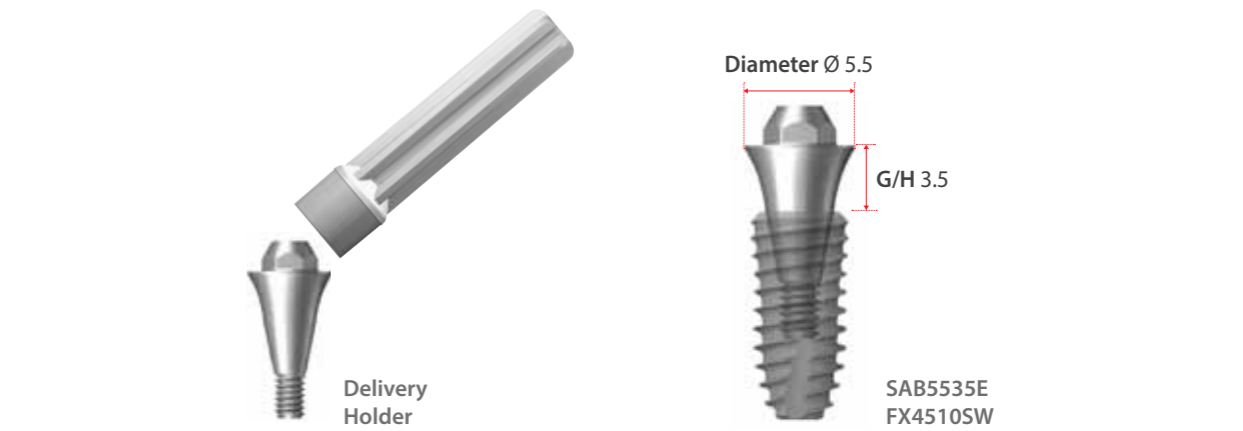

Diameter	G/H	Art. No.
Ø 4.5	1.0	SAB 45 10 E
	1.5	SAB 45 15 E
	2.5	SAB 45 25 E
	3.5	SAB 45 35 E
	4.5	SAB 45 45 E
	5.5	SAB 45 55 E



Diameter	G/H	Art. No.
Ø 5.5	1.5	SAB 55 15 E
	2.5	SAB 55 25 E
	3.5	SAB 55 35 E
	4.5	SAB 55 45 E
	5.5	SAB 55 55 E



Note: It is recommended to keep the torque level at 25~30 N-cm to tighten the screw abutment with fixture.

# Angled Screw Abutment

Unit: mm, Scale 1.5 : 1

· Abutment screw is included.

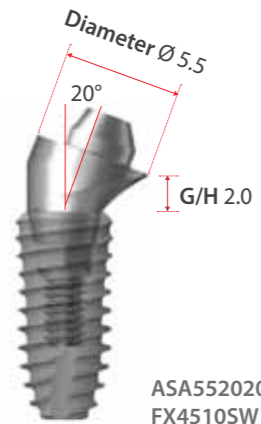

Diameter	G/H	Type	Art. No.
Ø 4.5	1.0	Hex	ASA 45 10 HE
	1.0	Non-hex	ASA 45 10 NE
	2.0	Hex	ASA 45 20 HE
	2.0	Non-hex	ASA 45 20 NE
	3.0	Hex	ASA 45 30 HE
	3.0	Non-hex	ASA 45 30 NE

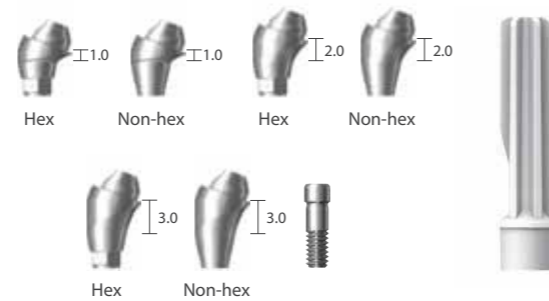

Diameter	G/H	Type	Art. No.
Ø 5.5	1.0	Hex	ASA 55 10 HE
	1.0	Non-hex	ASA 55 10 NE
	2.0	Hex	ASA 55 20 HE
	2.0	Non-hex	ASA 55 20 NE
	3.0	Hex	ASA 55 30 HE
	3.0	Non-hex	ASA 55 30 NE

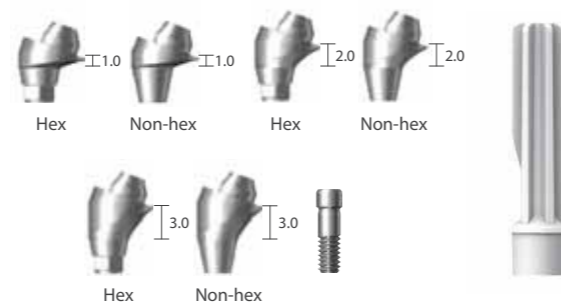

## Angled Screw Abutment Screw

Diameter	L	Art. No.
Ø 2.3	7.3	ASASC 20 23

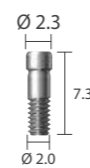

# Screw Abutment Impression Components

Unit: mm, Scale 1.5 : 1

## Impression Coping Pick-up

Diameter	Type	Art. No.
Ø 4.5	Single	Hex
	Bridge	Non-hex
Ø 5.5	Single	Hex
	Bridge	Non-hex

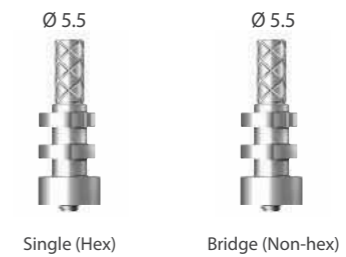
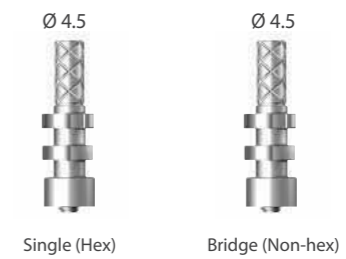

## Impression Coping Transfer

Diameter	Type	Art. No.
Ø 4.5	Single	Hex
	Bridge	Non-hex
Ø 5.5	Single	Hex
	Bridge	Non-hex

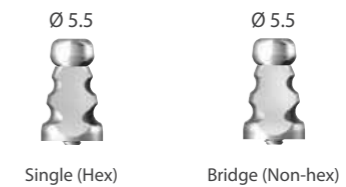
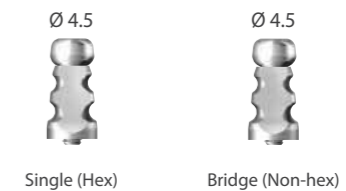

## Impression Coping Screw

Type	L	Art. No.
Pick-up	15.0	SPS 09
Transfer	9.0	STS 09

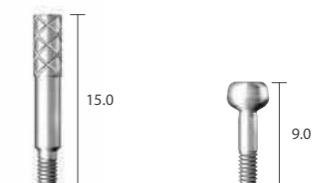

Note: It is recommended to keep the torque level at 25~30 N·cm to tighten the angled screw abutment with fixture.



# Screw Abutment Impression Components

Unit: mm, Scale 1.5 : 1

## Comfort Cap

Diameter	L	Art. No.
Ø 4.5	5.0	SCC 45 L
Ø 5.5		SCC 55 L



## Analog

Diameter	L	Art. No.
Ø 4.5	12.0	SAN 45 L
Ø 5.5		SAN 55 L

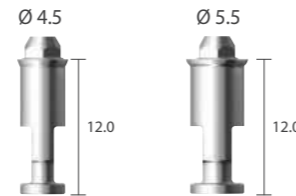

## Polishing Protector

Diameter	L	Art. No.
Ø 4.5	4.71	SPP 45 L
Ø 5.5		SPP 55 L

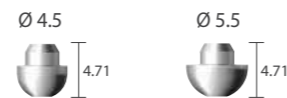

## Ti-Retaining Screw

Diameter	L	Art. No.
Ø 2.3	5.0	SRT 18 T

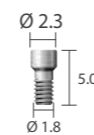

## Ti-Cylinder

Diameter	Type		Art. No.
Ø 4.5	Single	Hex	STA 45 S
	Bridge	Non-hex	STA 45 B
Ø 5.5	Single	Hex	STA 55 S
	Bridge	Non-hex	STA 55 B

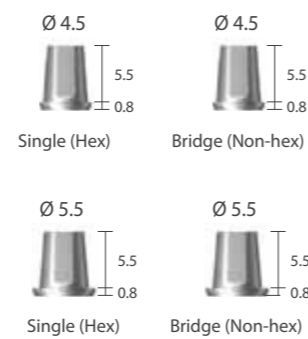

# Screw Abutment Impression Components

Unit: mm, Scale 1.5 : 1

## Ti-Temporary Cylinder

Diameter	Type		Art. No.
Ø 4.5	Single	Hex	STC 45 SG
	Bridge	Non-hex	STC 45 BG
Ø 5.5	Single	Hex	STC 55 SG
	Bridge	Non-hex	STC 55 BG

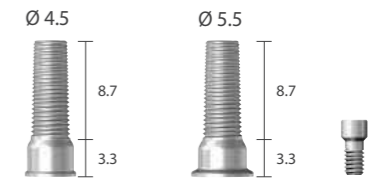

## Gold Cylinder

Diameter	Type		Art. No.
Ø 4.5	Single	Hex	SGC 45 SL
	Bridge	Non-hex	SGC 45 BL
Ø 5.5	Single	Hex	SGC 55 SL
	Bridge	Non-hex	SGC 55 BL

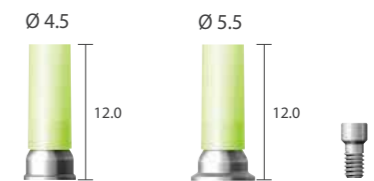

## Metal Cylinder | Co-Cr

Diameter	Type		Art. No.
Ø 4.5	Single	Hex	SGC 45 CSL
	Bridge	Non-hex	SGC 45 CBL
Ø 5.5	Single	Hex	SGC 55 CSL
	Bridge	Non-hex	SGC 55 CBL

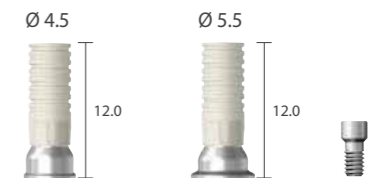

## Burn-out Cylinder

Diameter	Type		Art. No.
Ø 4.5	Single	Hex	SBC 45 SL
	Bridge	Non-hex	SBC 45 BL
Ø 5.5	Single	Hex	SBC 55 SL
	Bridge	Non-hex	SBC 55 BL

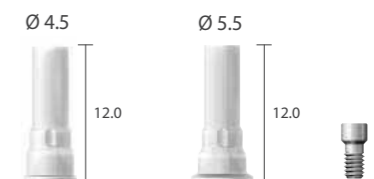

# Prosthetic Procedure 4

Impression Technique and Restoration Type

## Overdenture Procedure

### Positioner / Mini Ball / Magnetic Attachment

Page 35

**Positioner Abutment**  
Ø 3.5



Page 36

**Mini Ball Abutment**  
Ø 3.5



Page 38, 39

**Magnetic Implant Keeper**  
Dome type / Flat type  
Ø 4.5 / Ø 5.5



#### Abutment Level Impression

Page 35

**Positioner Impression Coping**  
Ø 4.5



Page 37

**Mini Ball Impression Coping**  
Ø 3.5



Page 35

**Positioner Analog**  
Ø 3.5



Page 37

**Mini Ball Analog**  
Ø 3.5



Page 36

**Block Out Spacer**  
Ø 6.5



Page 37

**Socket Spacer**  
Ø 4.05 / Ø 4.85



Page 36

**Positioner Socket**  
Metal / Plastic

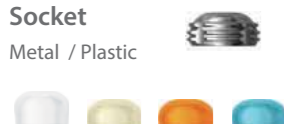

Page 37

**Mini Ball Female Socket / O-ring**  
Ø 4.05 / Ø 4.85



Page 38, 39

**Magnetic Assay**  
Dome type / Flat type  
Ø 4.5 / Ø 5.5



Positioner Attachment for Overdenture

Mini Ball and Socket Attachment for Overdenture

Magnetic Attachment for Overdenture

# Positioner

Unit: mm, Scale 1.5 : 1

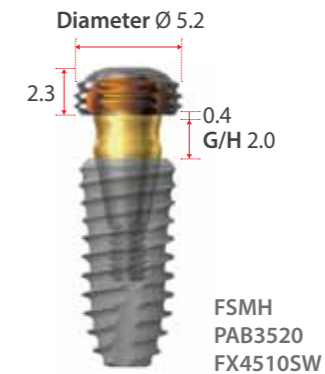

#### Positioner Abutment

Diameter	G/H	Art. No.
Ø 3.5	1.0	PAB 35 10
	2.0	PAB 35 20
	3.0	PAB 35 30
	4.0	PAB 35 40
	5.0	PAB 35 50
	6.0	PAB 35 60
	7.0	PAB 35 70

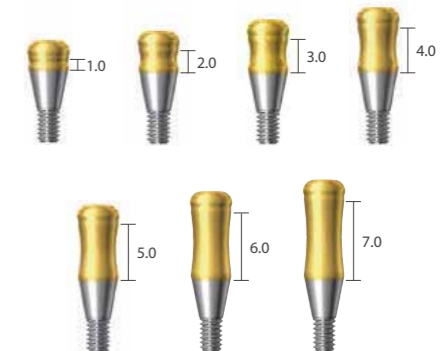

#### Positioner Impression Coping

Diameter	L	Art. No.
Ø 4.5	4.5	PIC



#### Positioner Analog

Diameter	L	Art. No.
Ø 3.5	12.4	PAN



Note: It is recommended to keep the torque level at 25~30 N·cm to tighten the positioner abutment with fixture.

# Positioner

Unit: mm, Scale 1.5 : 1

## Positioner Socket Set

Type	Art. No.
Tilting type ±10°	FSMHS
Non Tilting type ±5°	FSMHSN

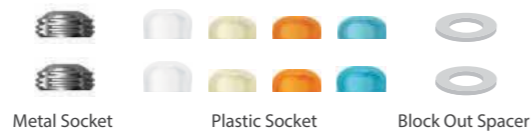

## Positioner Metal Socket

Diameter	H	Art. No.
Ø 5.2	2.3	FSMH

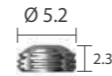

## Positioner Abutment

Type	Application	Art. No.
Tilting type ±10°	Blue 1,000gf	MSHP
	Orange 500gf	MSMP
	Ivory 300gf	MSLP
	White 100gf	MSOP
Non tilting type ±5°	Blue 1,000gf	MSHPN
	Orange 500gf	MSMPN
	Ivory 300gf	MSLPN
	White 100gf	MSOPN

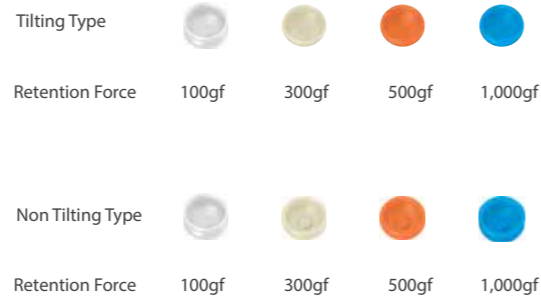

## Positioner Block Out Spacer

Diameter	H	Art. No.
Ø 6.5	0.5	FSMH



## Positioner Core Tool

XPCT



# Mini Ball Attachment

Unit: mm, Scale 1.5 : 1

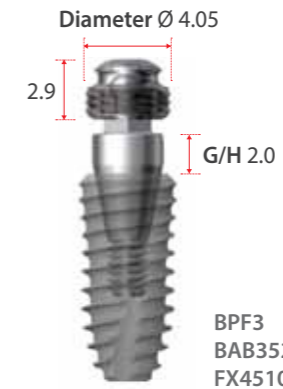

## Mini Ball Abutment

Diameter	G/H	Art. No.
Ø 3.3	0	BAB 35 00 18
Ø 3.5	1.0	BAB 35 10 18
Ø 3.5	2.0	BAB 35 20 18
Ø 3.5	3.0	BAB 35 30 18
Ø 3.5	4.0	BAB 35 40 18
Ø 3.5	5.0	BAB 35 50 18

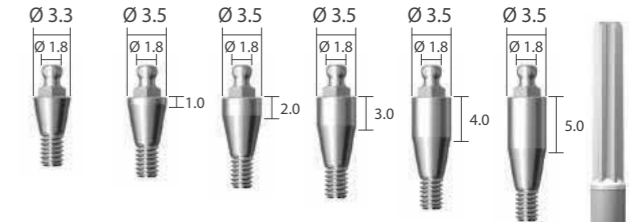

## Mini Ball Impression Coping

Diameter	L	Art. No.
Ø 4.0	5.0	GICA

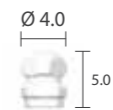

## Mini Ball Analog

Diameter	Art. No.
Ø 3.5	BANL



## Socket Spacer

Diameter	Art. No.
Ø 4.05	GBIC 3 L
Ø 4.85	GBIC 2 L



## Female Socket

Diameter	Retention Force	Art. No.
Ø 4.05	300~500gf	BPF 3
Ø 4.85	500~700gf	BPF 2

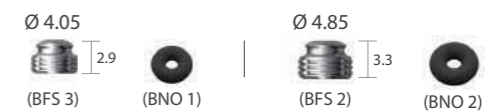

Note: It is recommended to keep the torque level at 25~30 N-cm to tighten the mini ball abutment with fixture.

# Magnetic Attachment\_Dome Type

Unit: mm, Scale 1.5 : 1

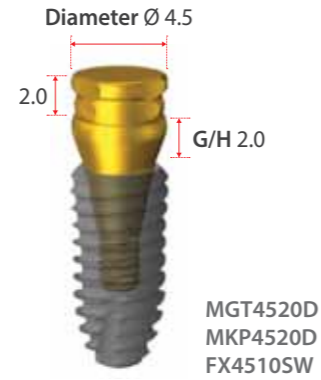

## Magnetic Assay

Application	Diameter	H	Art. No.
MKP45D	Ø 4.5	2.0	MGT 45 20 D
MKP55D	Ø 5.5	2.0	MGT 55 20 D

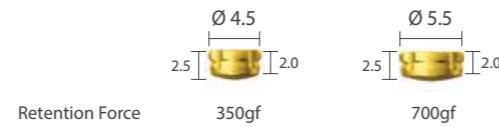

## Implant Keeper Diameter

Diameter	G/H	Art. No.
Ø 4.5	1.0	MKP 45 10 D
	2.0	MKP 45 20 D
	3.0	MKP 45 30 D
	4.0	MKP 45 40 D
	5.0	MKP 45 50 D
	6.0	MKP 45 60 D
Ø 5.5	1.0	MKP 55 10 D
	2.0	MKP 55 20 D
	3.0	MKP 55 30 D
	4.0	MKP 55 40 D
	5.0	MKP 55 50 D
	6.0	MKP 55 60 D

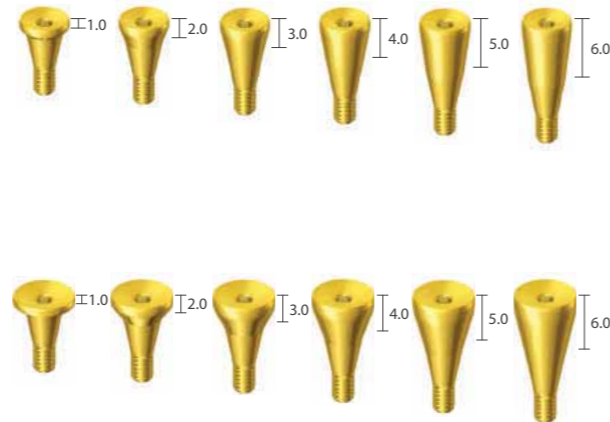

Note: It is recommended to keep the torque level at 25~30 N-cm to tighten the magnetic abutment with fixture.

# Magnetic Attachment\_Flat Type

Unit: mm, Scale 1.5 : 1



## Magnetic Assay

Application	Diameter	H	Art. No.
MKP 45	Ø 4.5	1.5	MGT 45 15
	Ø 4.5	2.0	MGT 45 20
MKP 55	Ø 5.5	1.5	MGT 55 15
	Ø 5.5	2.0	MGT 55 20

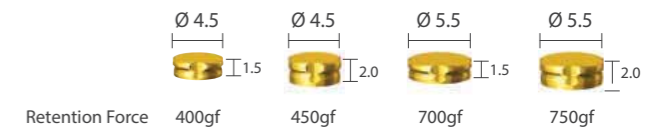

## Implant Keeper Diameter

Diameter	G/H	Art. No.
Ø 4.5	1.0	MKP 45 10
	2.0	MKP 45 20
	3.0	MKP 45 30
	4.0	MKP 45 40
	5.0	MKP 45 50
	6.0	MKP 45 60
Ø 5.5	1.0	MKP 55 10
	2.0	MKP 55 20
	3.0	MKP 55 30
	4.0	MKP 55 40
	5.0	MKP 55 50
	6.0	MKP 55 60

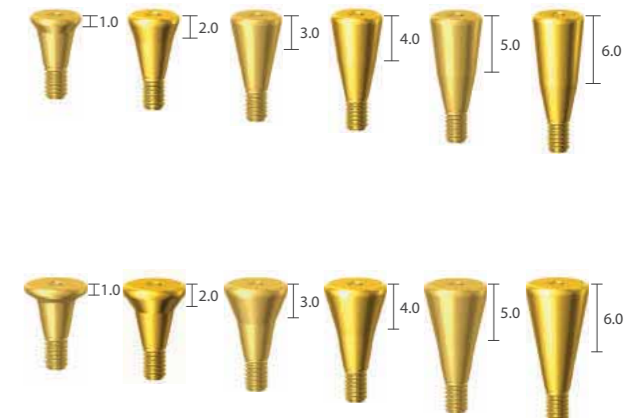

Note: It is recommended to keep the torque level at 25~30 N-cm to tighten the magnetic abutment with fixture.

# Surgical Kit\_Full

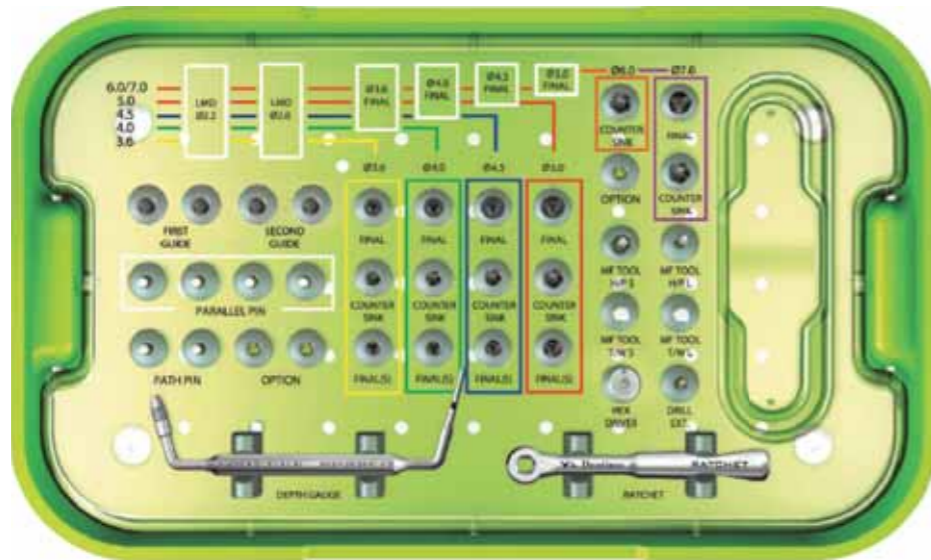

## SuperLine Surgical Full Kit

UXNF

### Kit Includes

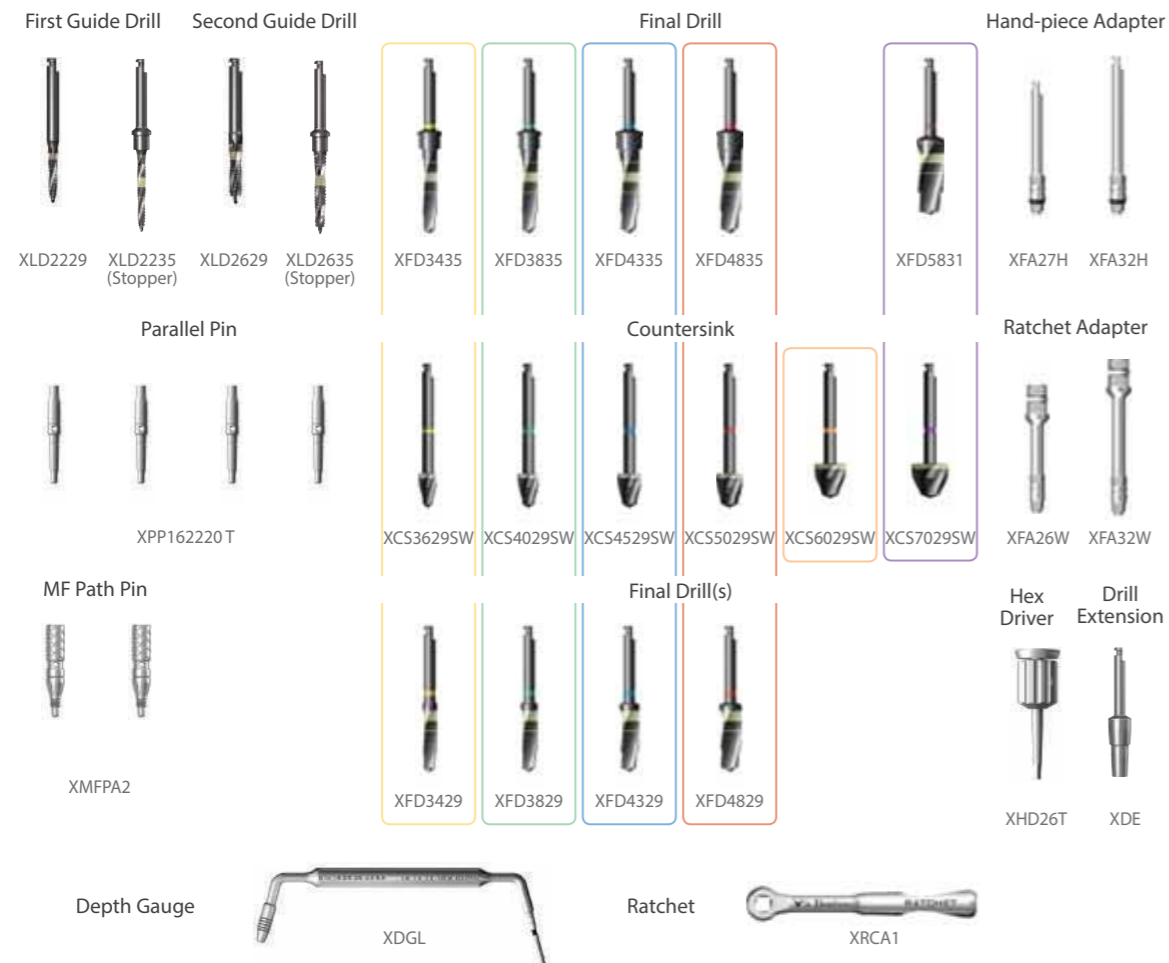

# Surgical Kit\_Standard



## SuperLine Surgical Standard Kit

UXNS

### Kit Includes



# Surgical Kit\_Short Implant

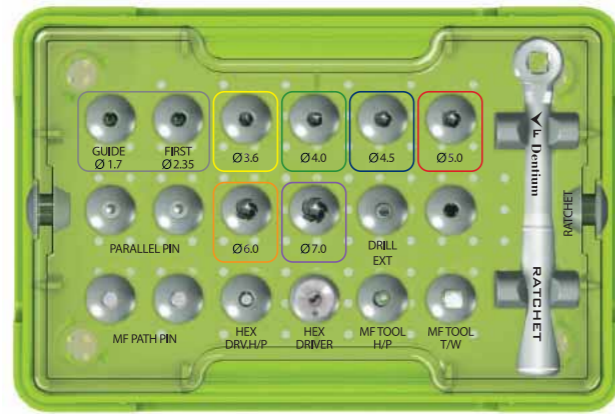

# Drill Stopper Kit

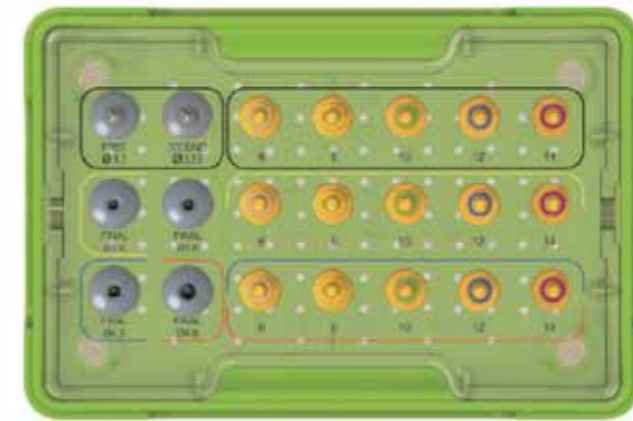

## SuperLine Short Implant Surgical Kit

XSIIK

### Kit Includes

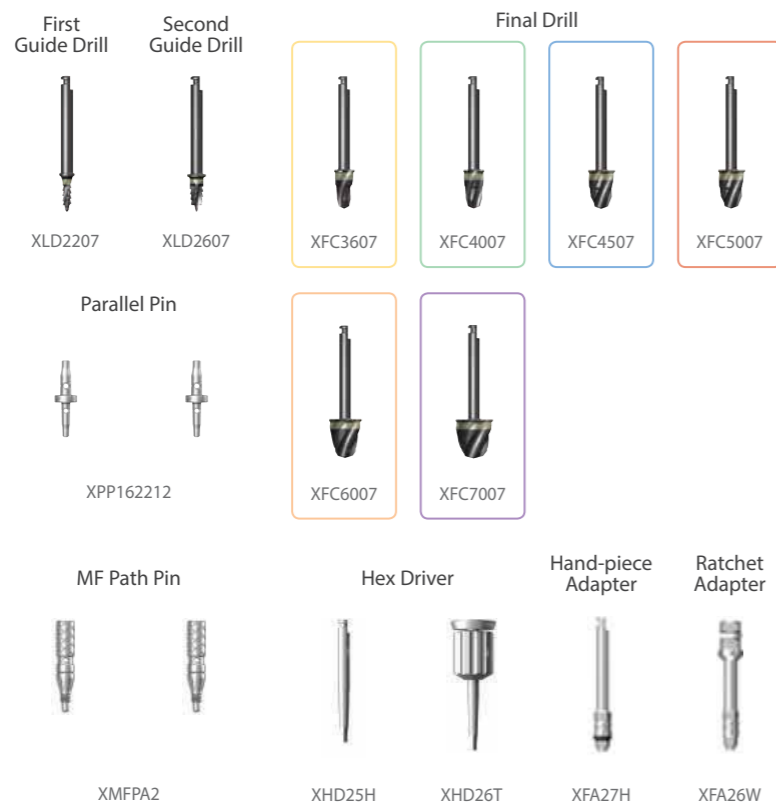

Ratchet



XRCA1

## Drill Stopper Kit

XDS

### Kit Includes

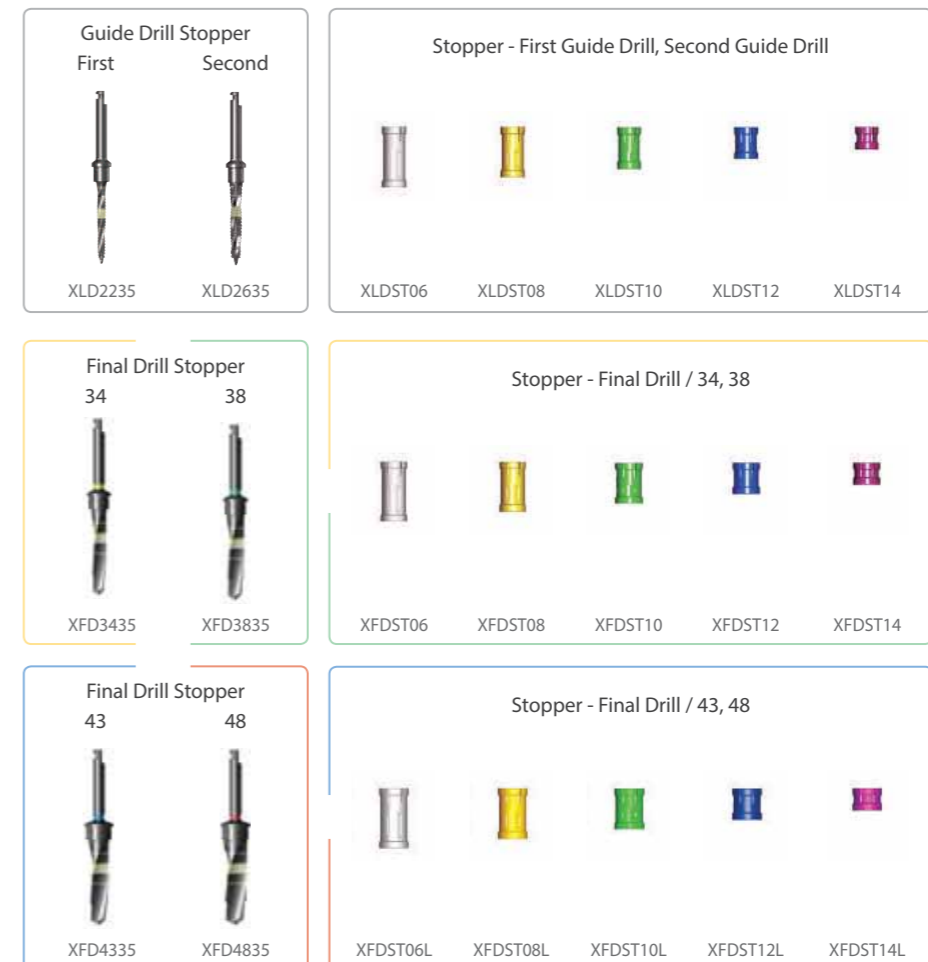

# Surgical Instruments

Unit: mm, Scale 1 : 1

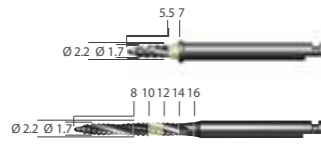

**First Guide Drill**

Diameter	L	Art. No.
Ø 2.2	26	XLD 22 07
	29	XLD 22 29
	31	XLD 22 31
	33	XLD 22 33
	35	XLD 22 35
	41	XLD 22 41

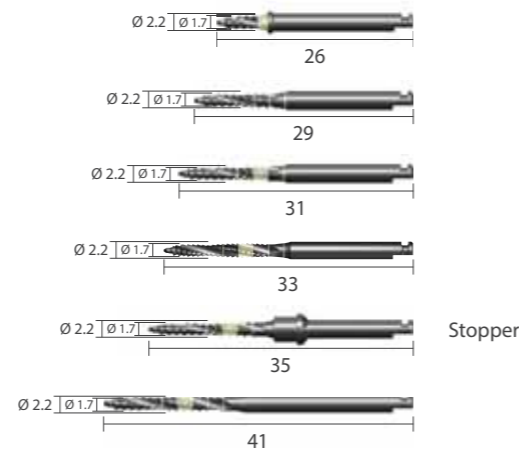

Stopper

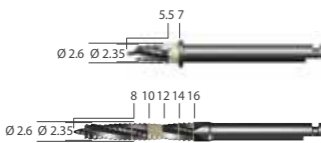

**Second Guide Drill**

Diameter	L	Art. No.
Ø 2.6	26	XLD 26 07
	29	XLD 26 29
	31	XLD 26 31
	33	XLD 26 33
	35	XLD 26 35
	41	XLD 26 41

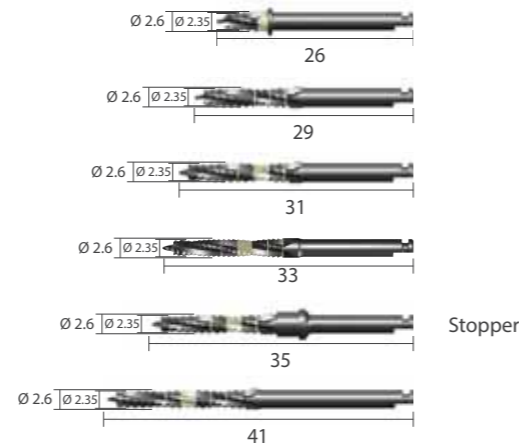

Stopper

Note: Drill speed 1,000rpm, 30~45 N-cm with irrigation



# Surgical Instruments

Unit: mm, Scale 1 : 1



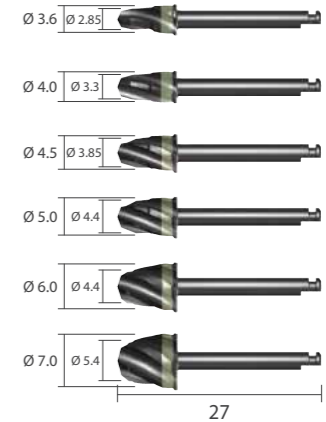

**Final Drill I For Short Drill**

Diameter	L	Art. No.
Ø 3.6	27	XFC 36 07
Ø 4.0		XFC 40 07
Ø 4.5		XFC 45 07
Ø 5.0		XFC 50 07
Ø 6.0		XFC 60 07
Ø 7.0		XFC 70 07

**Final Drill**

Diameter	L	Art. No.
Ø 2.9	29	XFD 34 29
Ø 3.35		XFD 38 29
Ø 3.85		XFD 43 29
Ø 4.4		XFD 48 29
Ø 5.4		XFD 58 29 SW

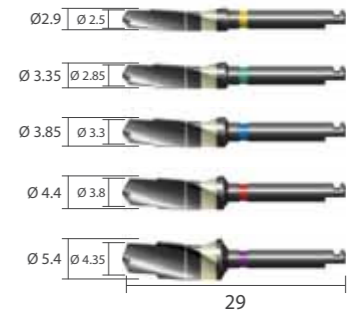
**Final Drill**

Diameter	L	Art. No.
Ø 2.9	31	XFD 34 31
Ø 3.35		XFD 38 31
Ø 3.85		XFD 43 31
Ø 4.4		XFD 48 31
Ø 5.4		XFD 58 31

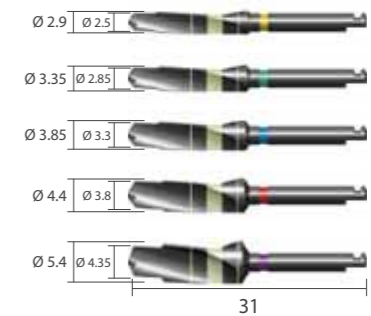

Note: Drill speed 1,000rpm, 30~45 N-cm with irrigation

# Surgical Instruments

Unit: mm, Scale 1 : 1

## Final Drill



Diameter	L	Art. No.
Ø 2.9	33	XFD 34 33
Ø 3.35		XFD 38 33
Ø 3.85		XFD 43 33
Ø 4.4		XFD 48 33



## Final Drill I Stopper



Diameter	L	Art. No.
Ø 2.9	35	XFD 34 35
Ø 3.35		XFD 38 35
Ø 3.85		XFD 43 35
Ø 4.4		XFD 48 35



## Final Drill



Diameter	L	Art. No.
Ø 2.9	41	XFD 34 41
Ø 3.35		XFD 38 41
Ø 3.85		XFD 43 41
Ø 4.4		XFD 48 41

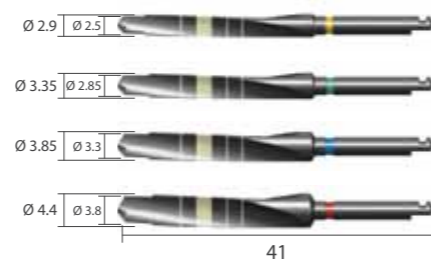

## Harvest Drill I Stopper



Diameter	L	Art. No.
Ø 2.85	35	XFH 34 35
Ø 3.3		XFH 38 35
Ø 3.85		XFH 43 35
Ø 4.4		XFH 48 35



Note: Drill speed 1,000rpm, 30~45 N-cm with irrigation

# Surgical Instruments

Unit: mm, Scale 1 : 1

## Countersink



Diameter	L	Art. No.
Ø 3.6	29	XCS 36 29 SW
Ø 4.0		XCS 40 29 SW
Ø 4.5		XCS 45 29 SW
Ø 5.0		XCS 50 29 SW
Ø 6.0	27	XCS 60 29 SW
Ø 7.0	27	XCS 70 29 SW



## Condensing Drill



Diameter	L	Art. No.
Ø 3.6	33	XCD 36 33
Ø 4.0		XCD 40 33
Ø 4.5		XCD 45 33
Ø 5.0		XCD 50 33
Ø 6.0	31	XCD 60 31
Ø 7.0	31	XCD 70 31

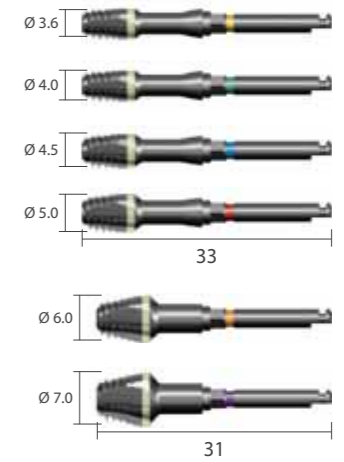

## Round Bur

Diameter	L	Art. No.
Ø 2.0	33	XRБ 20 33
Ø 3.0		XRБ 30 33



Note: 1. Countersink Drill & Round Bur speed 1,000rpm, 30~45 N-cm with irrigation  
2. Condensing Drill speed 20~60rpm, 30~45 N-cm with irrigation



# Surgical Instruments

Unit: mm, Scale 1 : 1

## Stopper | For first guide drill, second guide drill

Diameter	Drilling Depth	L	Art. No.
Ø 4.45	14	4.6	XLDST 14
	12	6.6	XLDST 12
	10	8.6	XLDST 10
	08	10.6	XLDST 08
	06	12.6	XLDST 06
	04	14.6	XLDST 04
	02	16.6	XLDST 02

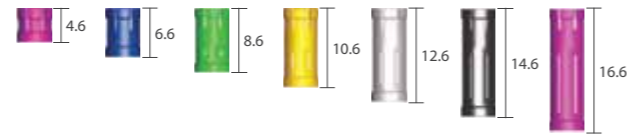

## Stopper | For final drill 3435, 3835

Diameter	Drilling Depth	L	Art. No.
Ø 5.14	14	4.6	XFDST 14
	12	6.6	XFDST 12
	10	8.6	XFDST 10
	08	10.6	XFDST 08
	06	12.6	XFDST 06
	04	14.6	XFDST 04
	02	16.6	XFDST 02

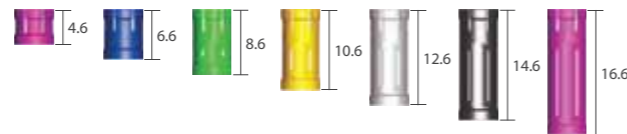

## Stopper | For final drill 4335, 4835

Diameter	Drilling Depth	L	Art. No.
Ø 5.14	14	4.6	XFDST 14 L
	12	6.6	XFDST 12 L
	10	8.6	XFDST 10 L
	08	10.6	XFDST 08 L
	06	12.6	XFDST 06 L
	04	14.6	XFDST 04 L
	02	16.6	XFDST 02 L

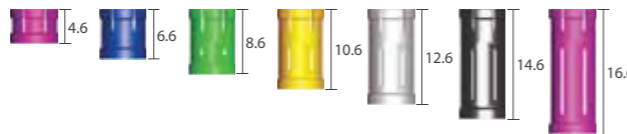

# Surgical Instruments

Unit: mm, Scale 1 : 1

## Adapter | Hex 2.5mm

Diameter	L	Art. No.
Hand-piece	27	XFA 27 H
	30	XFA 30 H
	32	XFA 32 H
Ratchet	21	XFA 21 W
	24	XFA 24 W
	26	XFA 26 W
	29	XFA 29 W
	32	XFA 32 W

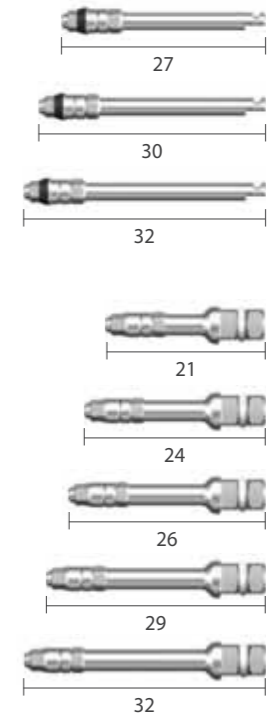

## Parallel Pin | For first guide drill, second guide drill

Diameter	L	Art. No.
Ø 1.6	15.5	XPP 162212
	20	XPP 162220 T
	26	XPP 162226 T

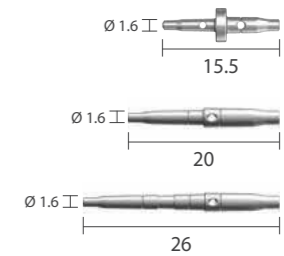

## Path Pin

Diameter	L	Art. No.
Ø 1.6	18.6	XMFP A 2



# Surgical Instruments

Unit: mm, Scale 1 : 1

## Hex Driver | Hex 1.28mm

Type	L	Art. No.
Hand-piece	25	XHD 25 H
Ratchet	21	XHD 21 W
	25	XHD 25 W
	27	XHD 27 W
Manual	26	XHD 26 T
	30	XHD 30 T

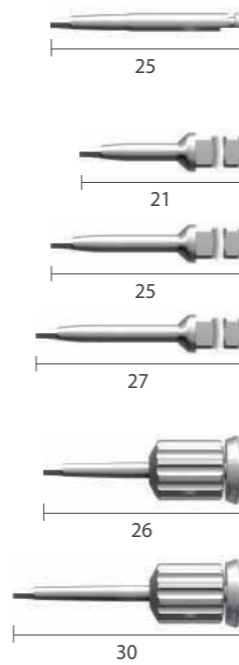

## Slot Driver

Type	L	Art. No.
Ratchet	17	SDA 17 R
	25	SDA 25 R

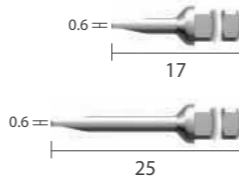

## Drill Extension

Diameter	L	Art. No.
Ø 3.0	26	XDE

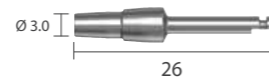

## Driver

Type	Diameter	Art. No.
Manual	Ø 12.0	XHDHT

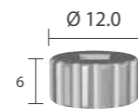

# Surgical Instruments

Unit: mm, Scale 1 : 1

## Screw & Ball Abutment Adapter

Type	L	Art. No.
Hand-piece	20	XMAA 1
Ratchet	21	XMA 21 W

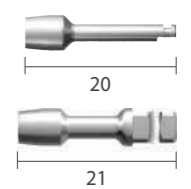

## Mini Ball Abutment Adapter

Type	L	Art. No.
Ratchet	21	IPST 21 W



## Ratchet

Scale 0.7 : 1

XRCA 1
--------



## Torque Wrench

Scale 0.7 : 1

XNTW
------



## Depth Gauge

Scale 0.7 : 1

XDGL
------

Note: One side of Depth Gauge measures the osteotomy depth and the other side measures the gingival height from the top of the implant.



## Tissue Punch

Diameter	L	Art. No.
Ø 4.0	27	XTS 40



# DASK

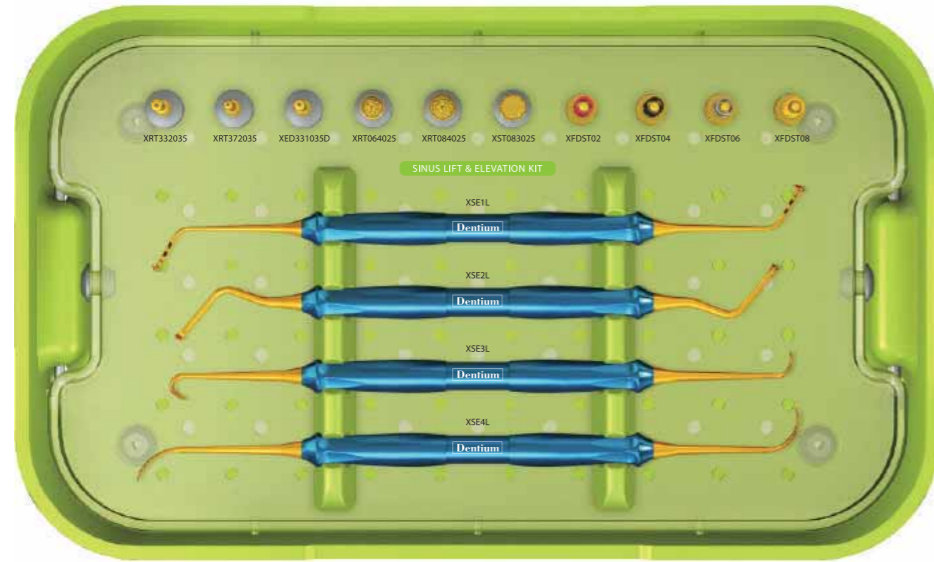

## Dentium Advanced Sinus Kit

## DASK

Kit Includes

DASK Drill

Stopper



Sinus Elevation Instrument



# Sinus Bur Kit

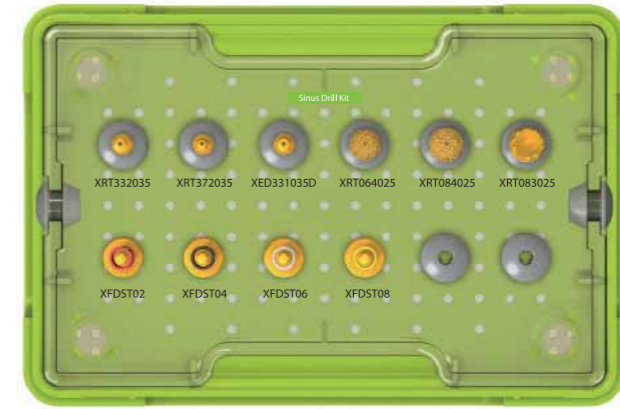

## Sinus Bur Kit

## SDK

Kit Includes

DASK Drill



Stopper



# Sinus Kit

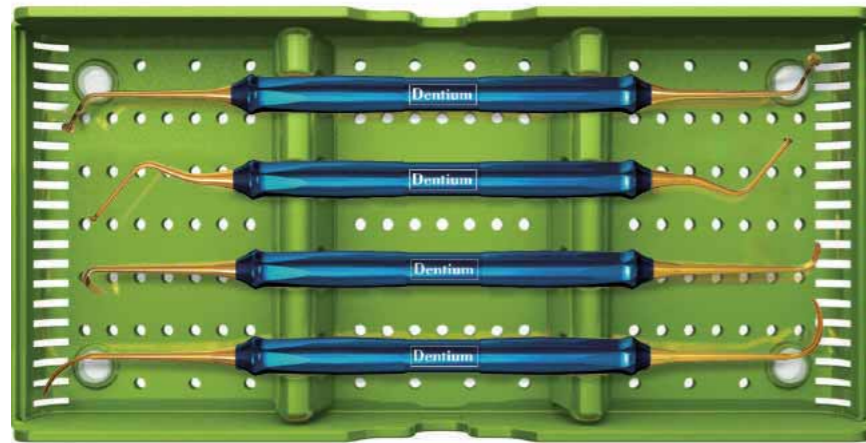

## Sinus Bur Kit

XSKL

Kit Includes

### Sinus Elevation Instrument



# DASK / Sinus Bur Kit

Unit: mm, Scale 1 : 1

## DASK Drill

Type	DASK Drill #	Art. No.
Crestal Approach	DASK Drill #1	XRT 33 20 35
	DASK Drill #2	XRT 37 20 35
	DASK Drill #3	XED 33 10 35 D
Lateral Approach	DASK Drill #4	XRT 06 40 25
	DASK Drill #5	XRT 08 40 25
	DASK Drill #6	XST 08 30 25

Note: Drill speed 800 to 1,200rpm, 30~45N-cm with irrigation

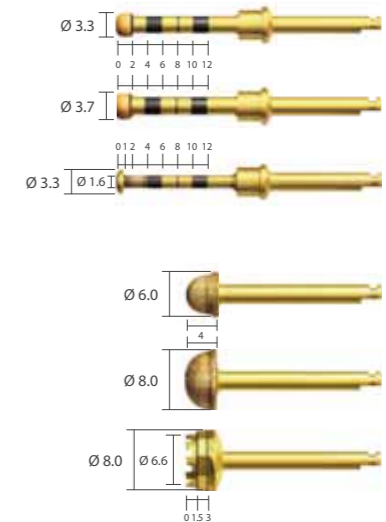

## Stopper | For XRT332035, XRT372035, XED331035D

Diameter	Drilling Depth	L	Art. No.
Ø 5.14	08	10.6	XFDST 08
	06	12.6	XFDST 06
	04	14.6	XFDST 04
	02	16.6	XFDST 02

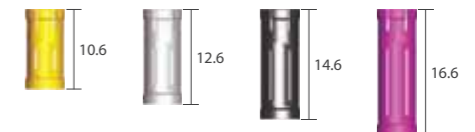

# TN Brush

## TN Brush

Diameter	Art. No.
Ø0.8	TN-0.8
Ø1.0	TN-1.0
Ø1.3	TN-1.3



# Osteotome Kit

Unit: mm, Scale 1 : 1

## Osteotome

Osteotome compresses the bone laterally, providing denser bony interface rather than removing valuable bone from the surgical site.



## Osteotome Kit

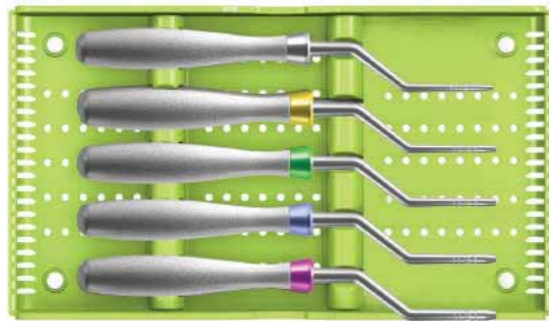

XOFK Type A (Convex)	XOFBK Type B (Concave)
XOF 20 A1	XOF 20 B1
XOF 34 A1	XOF 34 B1
XOF 38 A1	XOF 38 B1
XOF 43 A1	XOF 43 B1
XOF 48 A1	XOF 48 B1

## Osteotome | Final drill type | Scale 0.4 : 1

Type	Ø A	Ø B	Art. No.
Type A (Convex)	Ø 1.7	Ø 2.8	XOF 20 A1
	Ø 2.3	Ø 2.8	XOF 34 A1
	Ø 2.7	Ø 3.2	XOF 38 A1
	Ø 2.8	Ø 3.8	XOF 43 A1
	Ø 3.0	Ø 4.3	XOF 48 A1
Type B (Concave)	Ø 1.7	Ø 2.8	XOF 20 B1
	Ø 2.3	Ø 2.8	XOF 34 B1
	Ø 2.7	Ø 3.2	XOF 38 B1
	Ø 2.8	Ø 3.8	XOF 43 B1
	Ø 3.0	Ø 4.3	XOF 48 B1

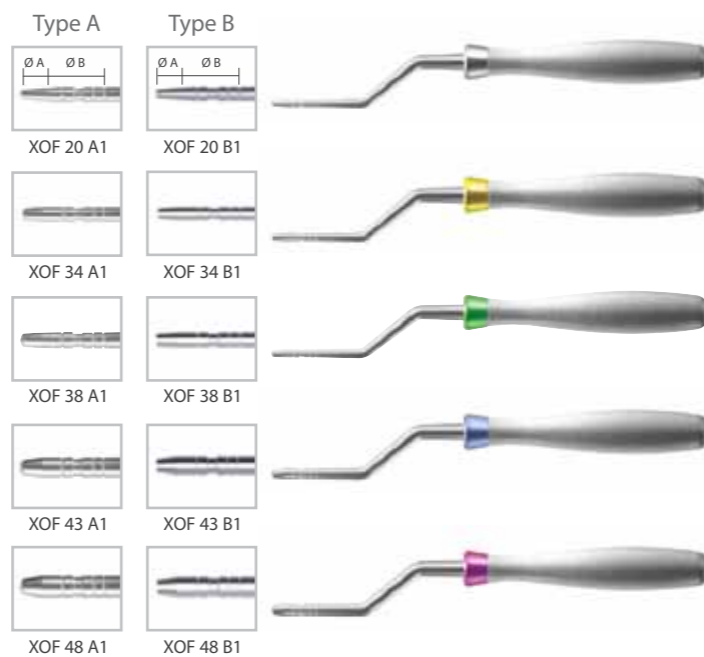

# Trephine Kit

Unit: mm, Scale 1 : 1

## Trephine Bur

- Excellent fine cutting
- Strong engagement when attaching the trephine to cortical bone
- Cut-outs facilitates ease of harvest retrieval
- 5 scale marks on the Trephine drill from 2mm to 10mm
- Easy harvesting

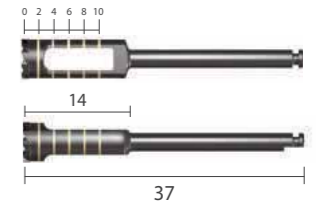

## Trephine Kit

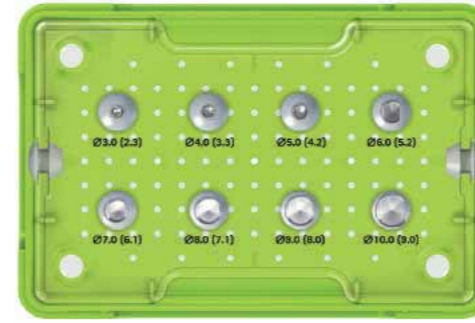

XIT Kit Includes			
XTP 24 03	XTP 34 04	XTP 44 05	XTP 54 06
XTP 64 07	XTP 74 08	XTP 84 09	XTP 94 10

## Trephine Bur

Outer Diameter	Inner Diameter	Art. No.
Ø 3.0	Ø 2.3	XTP 24 03
Ø 4.0	Ø 3.3	XTP 34 04
Ø 5.0	Ø 4.2	XTP 44 05
Ø 6.0	Ø 5.2	XTP 54 06
Ø 7.0	Ø 6.1	XTP 64 07
Ø 8.0	Ø 7.1	XTP 74 08
Ø 9.0	Ø 8.0	XTP 84 09
Ø 10.0	Ø 9.0	XTP 94 10



# Prosthetic Kit

Unit: mm, Scale 1 : 1

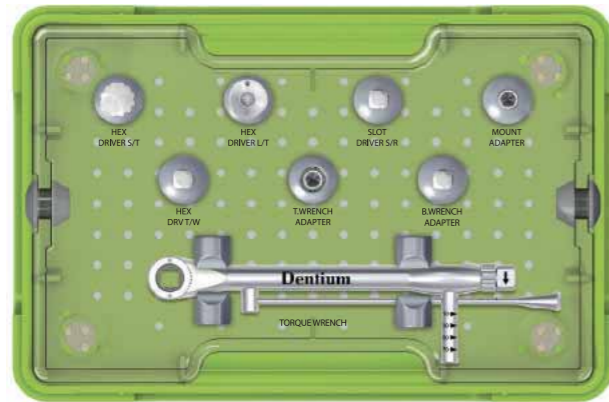

XIP

## Hex Driver

Type	L	Art. No.
S/T	15	XHD 15
L/T	30	XHD 30 T
Torque Wrench	25	XHD 25 W



## Adapter

Type	L	Art. No.
Torque Wrench	21	XMA 21 W
Mini Ball	21	IPST 21 W
Mount	20	XMAA 1



## Slot Driver

SDA 25 R
----------



## Torque Wrench

XNTW
------

Scale 0.7 : 1



# Planning Kit

Unit: mm, Scale 1 : 1



XPK

## For Combi & Dual Abutment

Diameter	G/H	Art. No.
Ø 4.5	1.5	PDAB 45 15
	2.5	PDAB 45 25
	3.5	PDAB 45 35
	4.5	PDAB 45 45
	5.5	PDAB 45 55
Ø 5.5	1.5	PDAB 55 15
	2.5	PDAB 55 25
	3.5	PDAB 55 35
	4.5	PDAB 55 45
	5.5	PDAB 55 55
Ø 6.5	1.5	PDAB 65 15
	2.5	PDAB 65 25
	3.5	PDAB 65 35
	4.5	PDAB 65 45
	5.5	PDAB 65 55

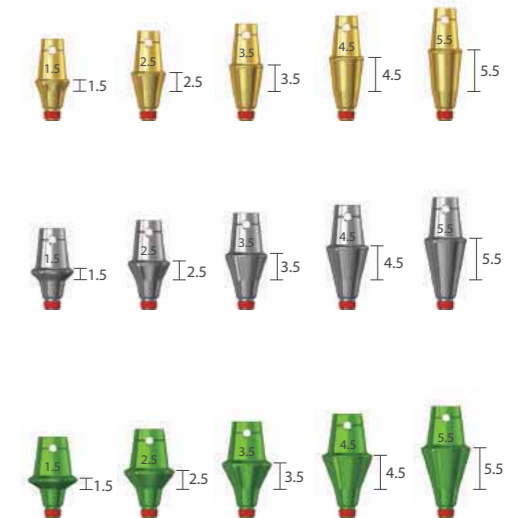

## For Angled Abutment

Angled	Diameter	G/H	Art. No.
15°	Ø 4.5	2.0	PAAB 15 45 20
		4.0	PAAB 15 45 40
	Ø 5.5	2.0	PAAB 15 55 20
		4.0	PAAB 15 55 40
25°	Ø 4.5	2.0	PAAB 25 45 20
		4.0	PAAB 25 45 40
	Ø 5.5	2.0	PAAB 25 55 20
		4.0	PAAB 25 55 40



# Prosthetic and Laboratory Instrument

Unit: mm, Scale 1 : 1

## Hex Driver

Hex	L	Art. No.
1.28	13	XHD 13
	15	XHD 15
	21	XHD 21
	28	XHD 28

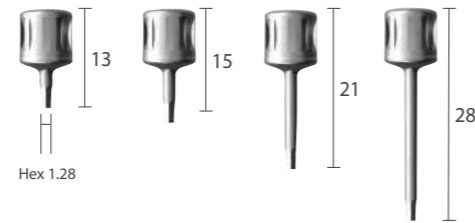

## Reamer Guide

Application	Diameter	Art. No.
Combi / Dual Abutment	Ø 4.5	CRG 45 L
	Ø 5.5	CRG 55 L
	Ø 6.5	CRG 65 L

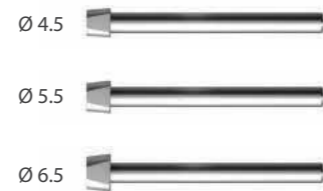

Application	Type	Art. No.
Screw Abutment	Bridge	SRG BL
	Single	SRG SL



## Reamer Handle

Scale 0.5 : 1

CRH
-----



## Hand Wrench

XHW
-----



## Reamer

Application	Art. No.
Combi / Dual Abutment	CRM
Screw Abutment	SRM



# Help Kit

Unit: mm, Scale 1 : 1

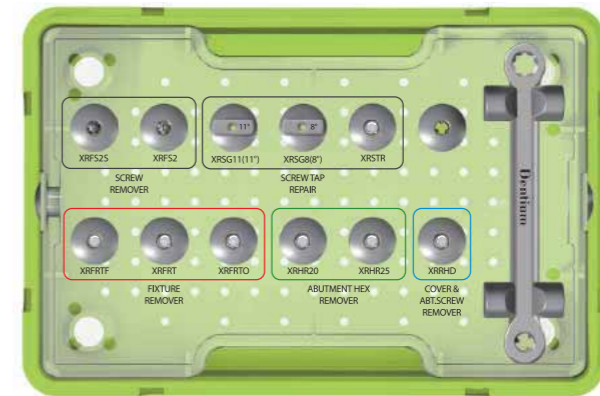

## XIH

### Screw Remover

L	Art. No.
25	XRFS 2 S
33	XRFS 2

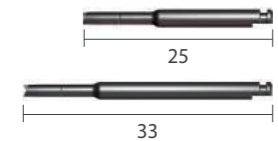

### Screw Tap Repair

Type	Art. No.
Tap	XRSTR
11° Guide	XRSG 11
8° Guide	XRSG 8



### Fixture Remover

Type	Art. No.
-	XRFRT
11°	XRFARTF
8°	XRFRT0

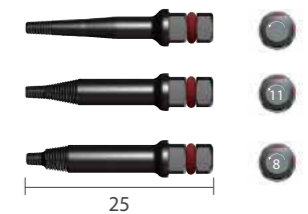

### Abutment Hex Remover

L	Art. No.
20	XRHR 20
25	XRHR 25

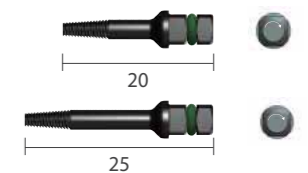

### Cover & Abutment Screw Remover

L	Art. No.
25	XRRHD

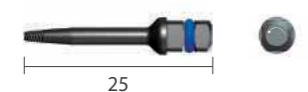

### Wrench

Scale 1 : 0.7

WRFRW
-------

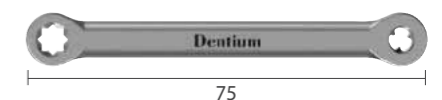

# Polymer Guide Kit

Unit: mm, Scale 1 : 1



PGSSK



PGSCK

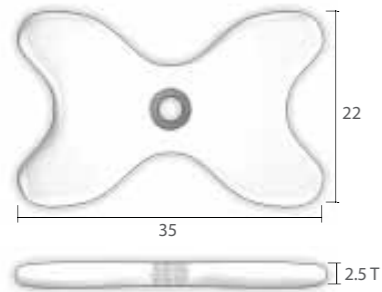

### Single Standard (5ea)

T	Art. No.
2.5	XSG 34 <b>35</b> S

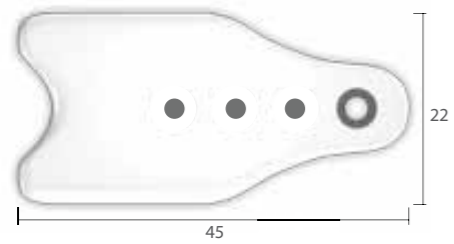

### Cantilever Multi-Ready (5ea)

T	Art. No.
2.5	XSG 34 <b>45</b> C

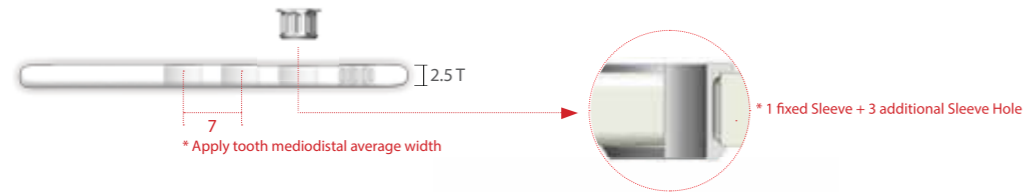

· Stone Drill



XGD **23 60** (5ea)

· Guide Pin



XGP **34 23 S** (5ea)

· Additional Metal Sleeve  
(for Cantilever Multi-Ready)



XPGS **34 25 A** (5ea)

## New Instrument Kit

# Sinus Kit

Unit: mm, Scale 1 : 1

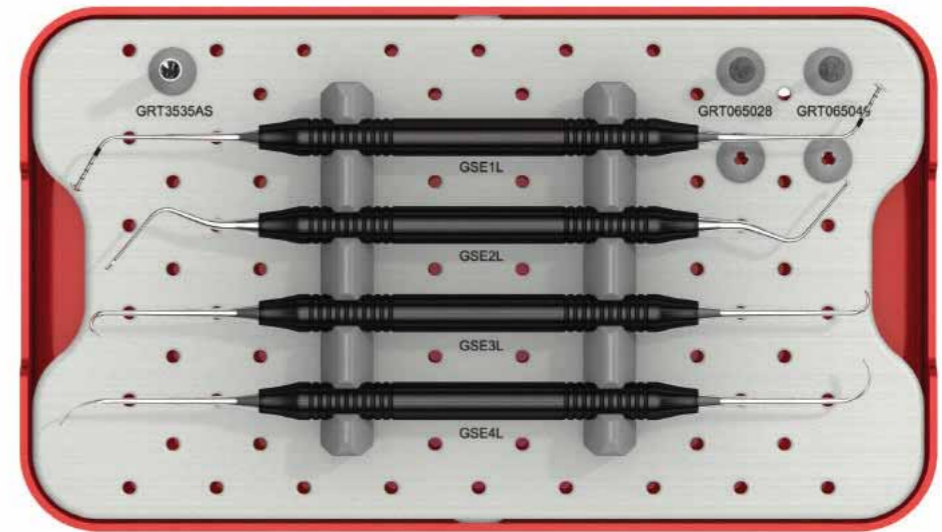

GSEK

### Crestal Drill

Diameter	L	Art No.
Ø3.5	35	GRT 35 35 AS



### Lateral Drill

Diameter	L	Art No.
Ø6.0	28	GRT 06 50 28
Ø6.0	40	GRT 06 50 40

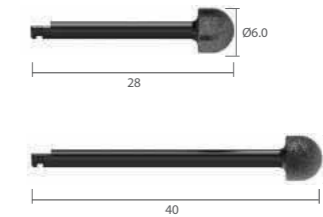

### Sinus Curette Scale 1 : 2 / mm





New Instrument Kit

# Ridge Expander Kit

Unit: mm, Scale 1 : 1

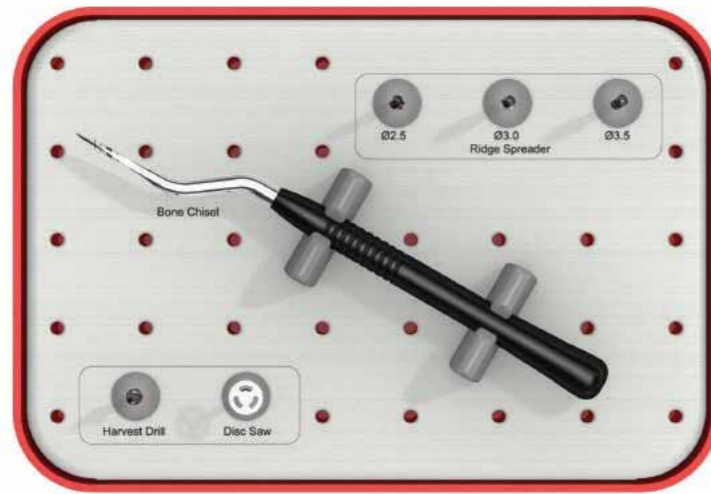

GREK

Ridge Spreader

Diameter	L	Art No.
Ø1.3 / Ø2.5	32	GRS 13 25
Ø1.8 / Ø3.0	32	GRS 18 30
Ø2.3 / Ø3.5	32	GRS 23 35

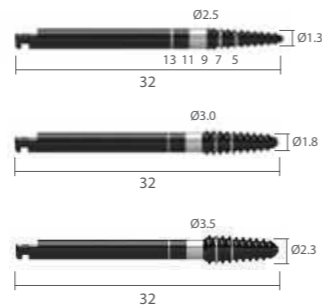

Harvest Drill

Diameter	L	Art No.
Ø3.0	29	GHD 30 29

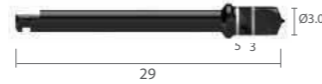

Disc Saw

Diameter	L	Art No.
Ø8.0	25	GDS 80 25

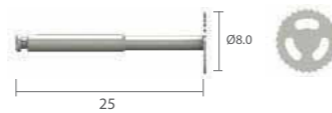

Bone Chisel

Art No.	Art No.
GBC 18 45 13	GBC 18 45 13



New Instrument Kit

# Implant Guide Kit

Unit: mm, Scale 1 : 1

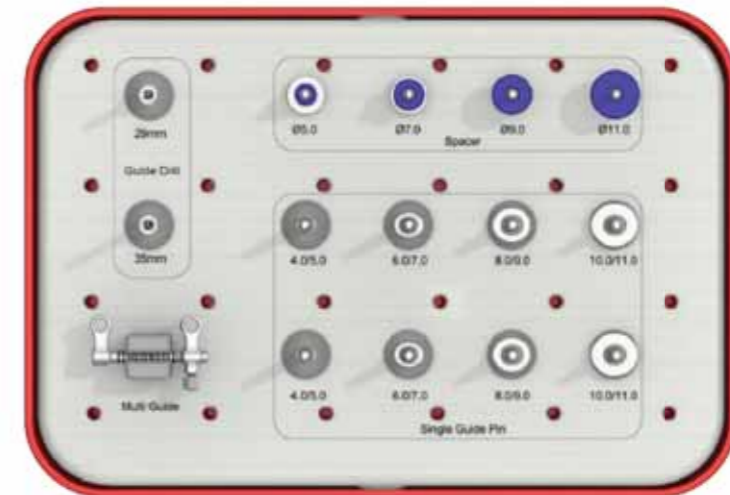

GIGK

Guide Drill

Diameter	L	Art No.
Ø2.6	29	GGD 26 29
Ø2.6	35	GGD 26 35

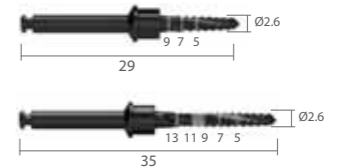

Spacer

Width	Art No.
5.0	GSP 05
7.0	GSP 07
9.0	GSP 09
11.0	GSP 11



Single Guide Pin

Width	Art No.
4.0 / 5.0	GGP 04 05
6.0 / 7.0	GGP 06 07
8.0 / 9.0	GGP 08 09
10.0 / 11.0	GGP 10 11

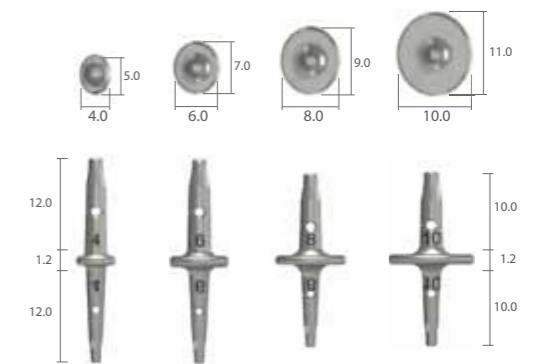

Multi Guide

Art No.	Art No.
GMG2	GMG2



New Instrument Kit

# Digital Full Kit

Unit: mm, Scale 1 : 1



XGSFK

SuperLine FX4510SW  
Guided drilling Sequence

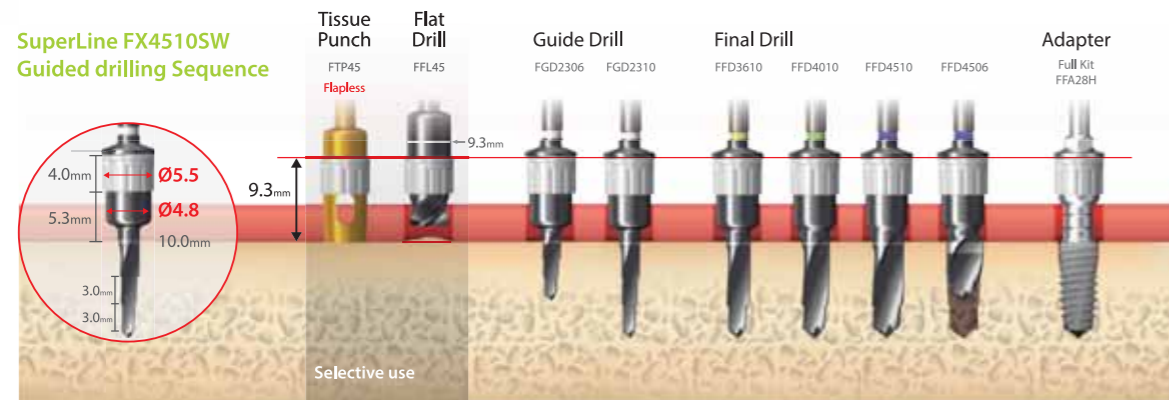

New Instrument Kit

# Digital Simple Kit

Unit: mm, Scale 1 : 1

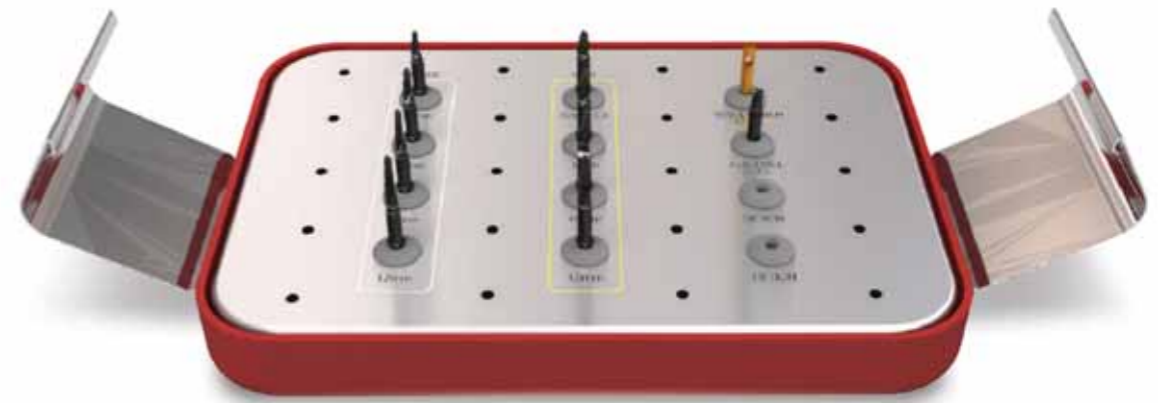

XGSSK

SuperLine FX3610SW  
Guide drilling Sequence

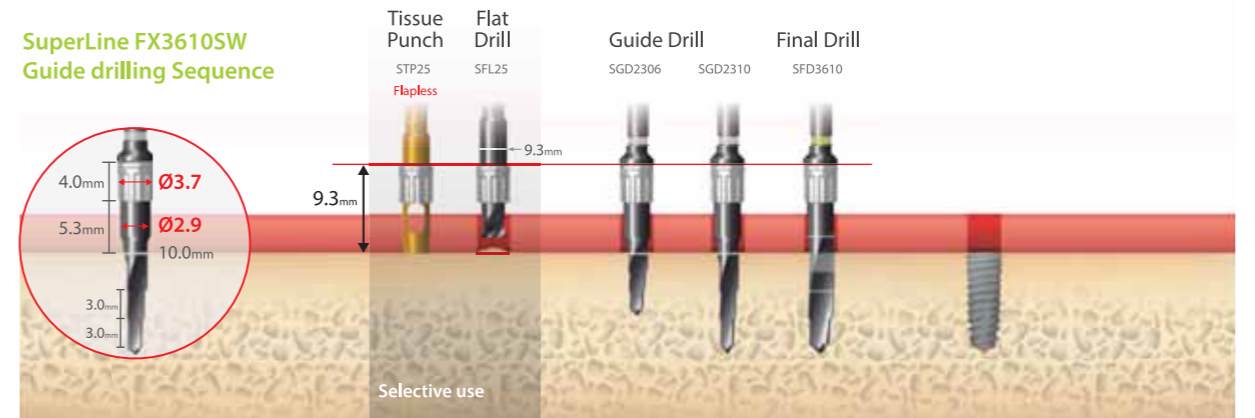

# Contents

<b>SURGICAL MANUAL</b>	Surgical Drill Sequence I	67
	Surgical Drill Sequence II	69
	Drilling Depth Guide	71
	Fixture Connection	73
	Installation Procedure & Warnings	74
	Surgical Kit Maintenance	75
<b>PROSTHESIS MANUAL</b>	Understanding the Implant and Prosthesis	77
	Types of Abutment	78
	Dual Abutment	79
	Combi Abutment	80
	Custom / Milling Abutment	81
	Angled Abutment	82
	Direct-Casting / Metal-Casting Abutment	83
	Temporary Abutment	84
	Screw Abutment	85
	Points to Consider in Abutment Selection	86
	Minimum Height Requirement for SuperLine Prosthetic Abutment	87
	<b>Prosthetic Procedure 1</b>	88
	Abutment Level - Dual Abutment	89
	Abutment Level - Combi Abutment	92
	<b>Prosthetic Procedure 2</b>	94
	Fixture Level - [Pick-up Type]_Dual Abutment	95
	Fixture Level - [Transfer Type]_Dual Abutment	98
	Fixture Level - [Transfer Type]_Milling Abutment	101
	Fixture Level - [Pick-up Type]_Angled Abutment	103
	Fixture Level - Direct-Casting Abutment	105
	Fixture Level - Metal-Casting Abutment	106
	Fixture Level - [Pick up Type]_Temporary Abutment	107
	<b>Prosthetic Procedure 3</b>	108
	Abutment Level - [Transfer Type]_Screw Abutment	109
	Cementation Repair Method (SCRIP)	112
	<b>Prosthetic Procedure 4</b>	114
	Positioner	115
	Mini Ball Attachment	118
	Magnetic Attachment	119

# Surgical Drill Sequence I

## Drilling Sequence Guide (Final Drill)

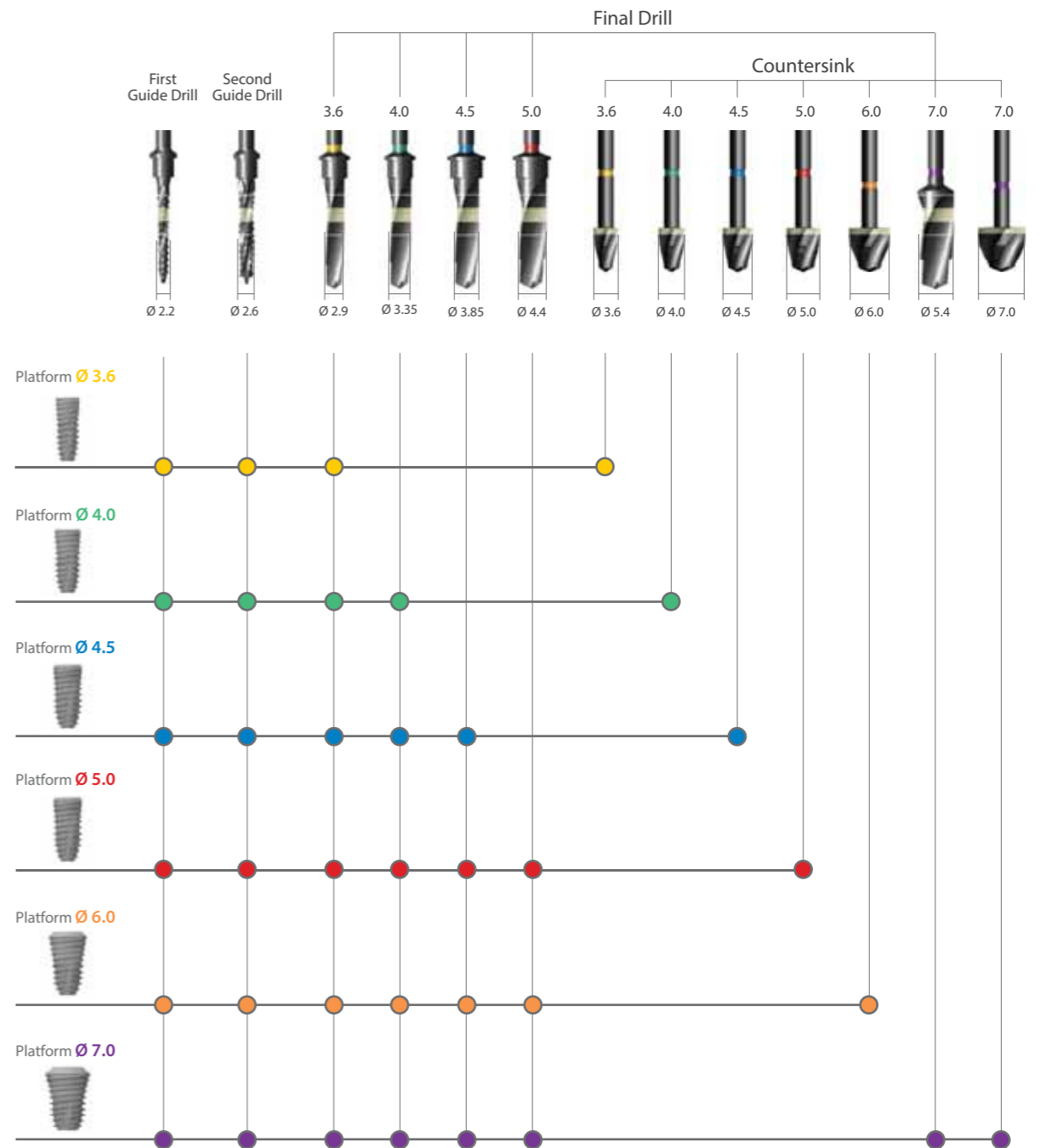



### Condensing Drill

- Condensing Drill speed 20~60rpm, 30~45 N-cm with irrigation
- If the bone density is D1~D2, it is recommended to Condensing drill after final drill.
- The actual diameter of the Condensing drill is 0.1mm larger than the fixture platform.



### Early loading with precise tap drill

- Tap drills for exquisite surgery to enable early loading.
- Smooth and precise surgery with tap drill in type 1~2 bone
- 4mm of tapping depth for optimum torque control.

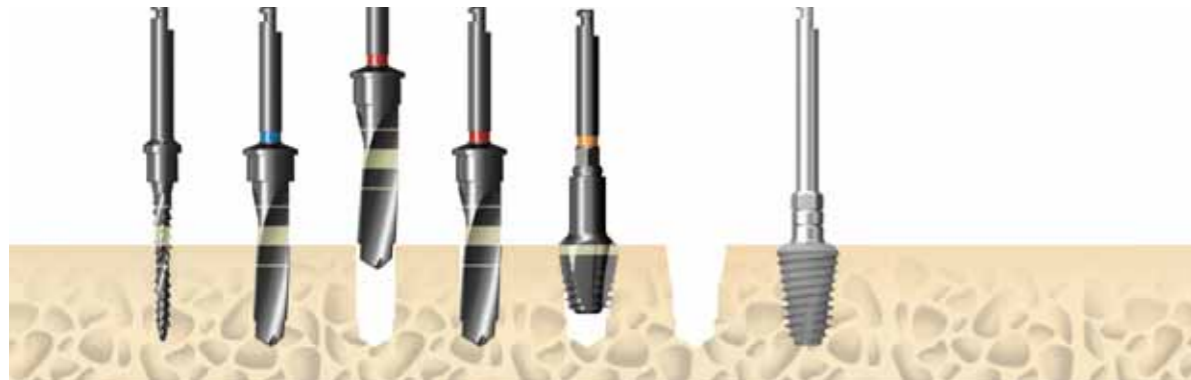

## Drilling Depth Guide

Platform: Ø3.6 / Body: Ø3.6 (1000rpm / 30~45N-cm)

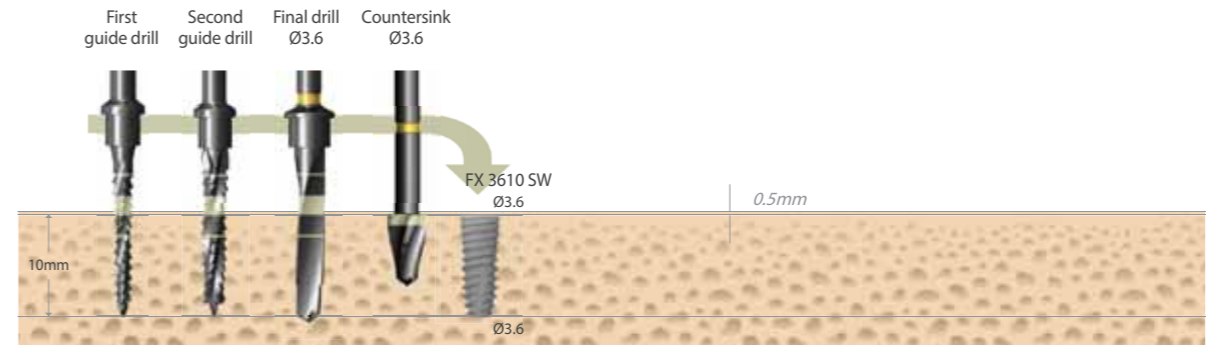

Platform: Ø4.0 / Body: Ø4.0 (1000rpm / 30~45N-cm)

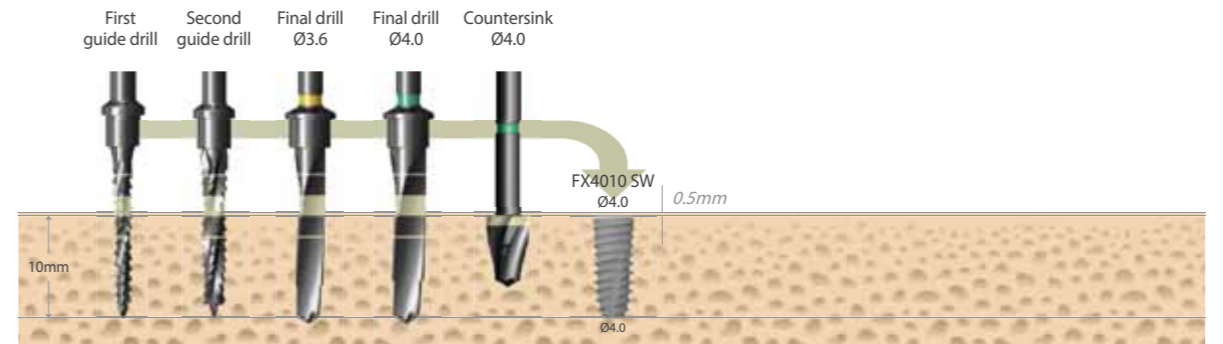

Platform: Ø4.4 / Body: Ø4.5 (1000rpm / 30~45N-cm)

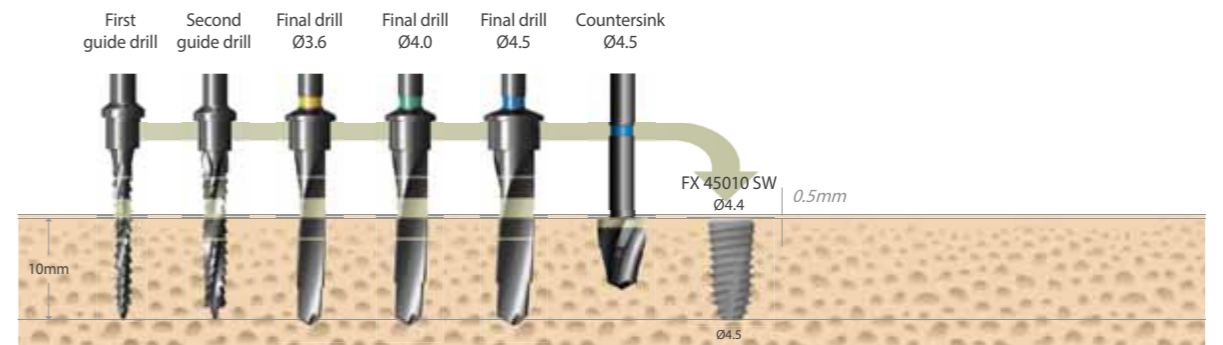

# Drilling Depth Guide

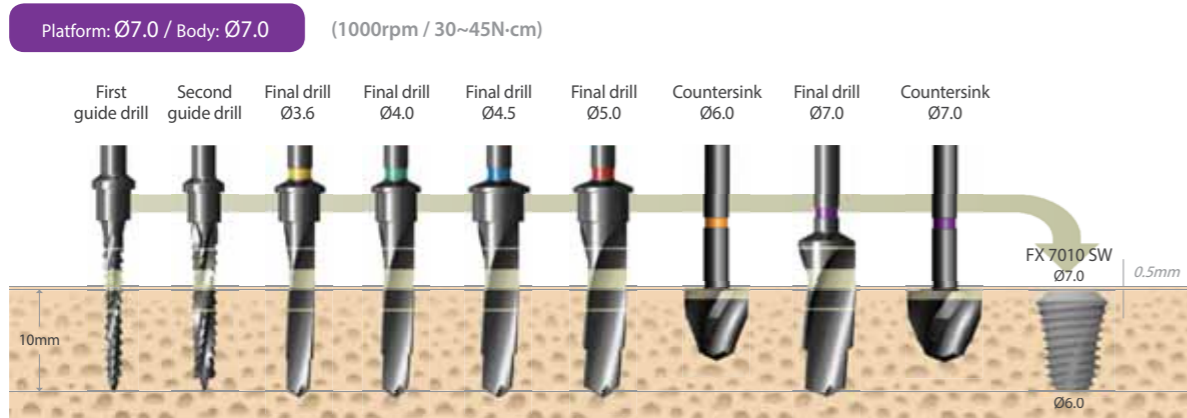
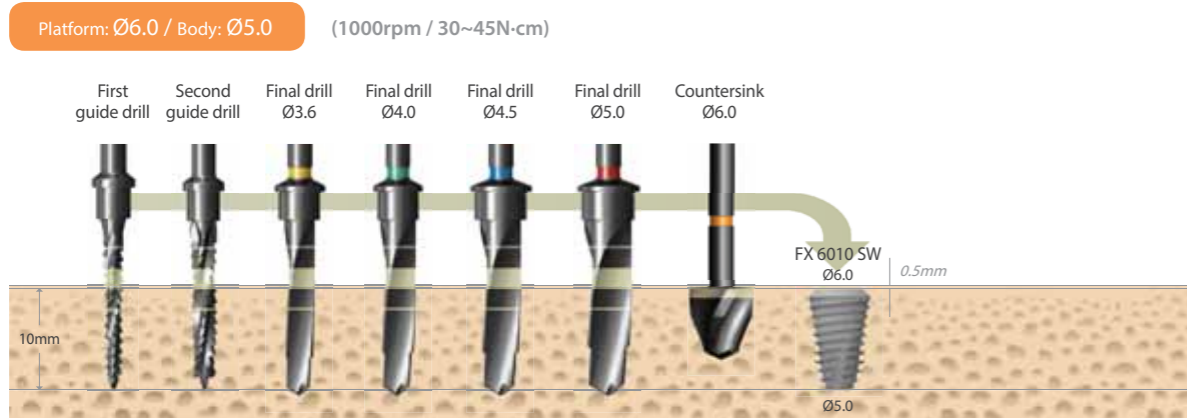
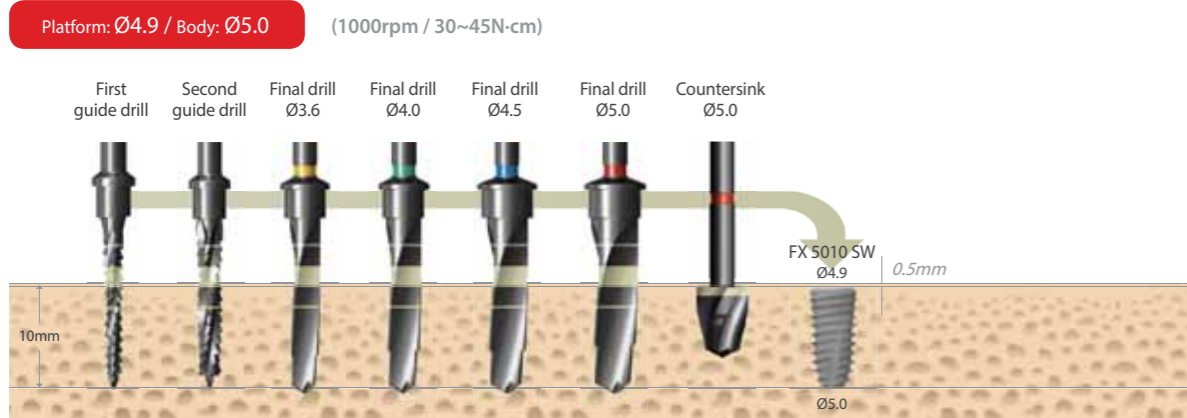

# Fixture Connection

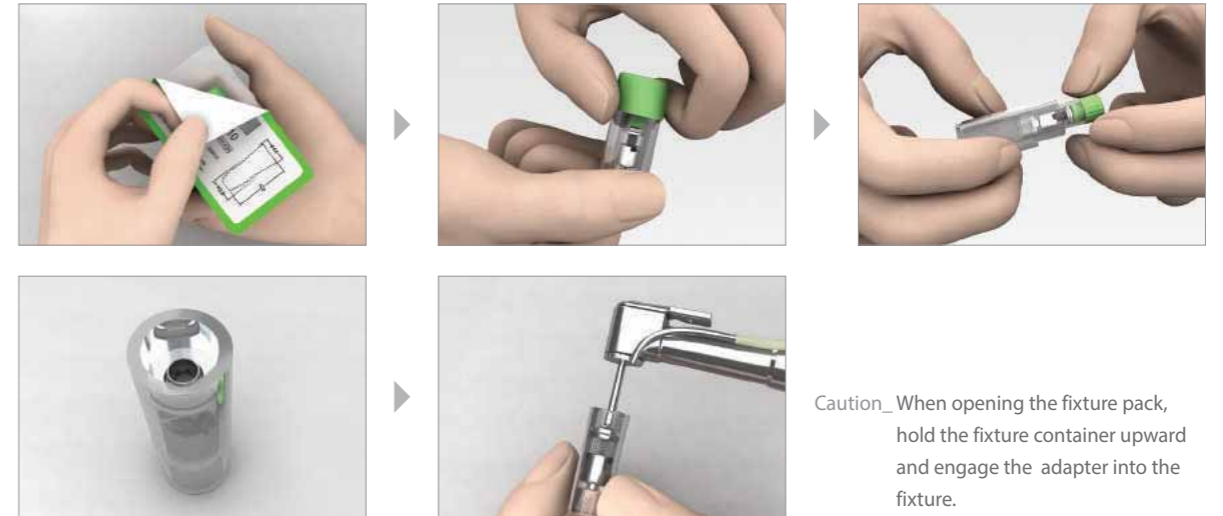

Caution\_ When opening the fixture pack, hold the fixture container upward and engage the adapter into the fixture.



## Directions Using the Hand-piece / Ratchet Adapter

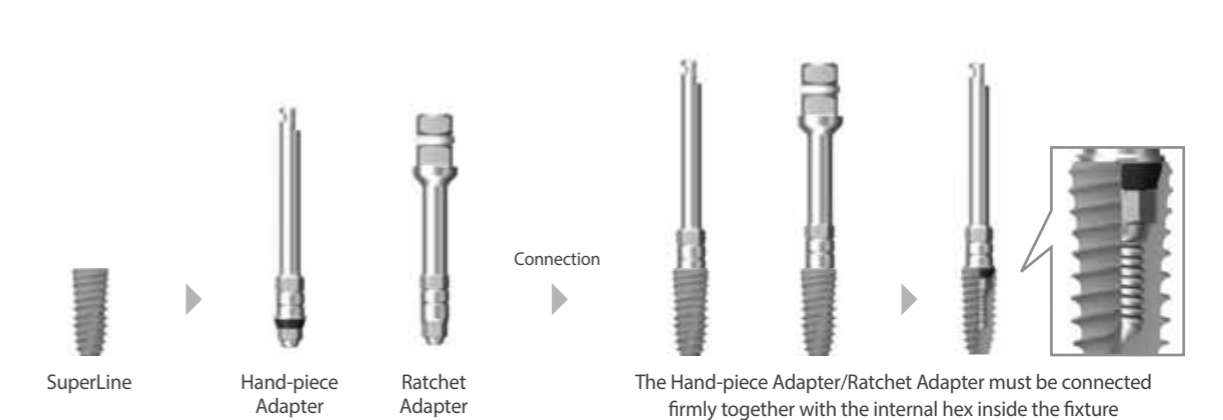

# Installation Procedure & Warnings

## Cover Screw



By Hex Driver



Cover Screw(CS36) connection

## Healing Abutment



By Hex Driver



Healing Abutment connection

Healing Abutment (HAB402020L)  
connection in thin gingiva

## Warnings

Dental Implant surgery and restoration involve complex dental procedures. Appropriate and adequate training in proper technique is strongly recommended prior to use.

- Improper medical examination and/or treatment plan can result in implant failure and/or loss of supportive bone.
- Improper initial stability and/or excessive occlusal forces during healing period may lead to osseointegration failure.
- Excessive insertion torque may lead to mechanical failure or implant biologic failure due to bone compression and necrosis.
- When forces or loads are greater than its design, implant or abutment fracture could happen. Therefore clinicians should make careful decisions with regards to clinical treatment planning to minimize the risk of fracture. Appropriate implant quantity, occlusal interface and a nightguard are essential. Potential excessive loading conditions may include the following:

- 01 Inadequate number of implants are placed.
- 02 Implant width and/or length are inappropriate for a treatment site.
- 03 Prosthesis which has excessive cantilever length due to inadequate biomechanical design
- 04 Continuous occlusal force are generated by incomplete connection between implant and abutment and/or abutment screw loosening.
- 05 Direct Casting Abutment angles are greater than 30° from the vertical axis of the implant.  
Direct Abutments are not for angulation.
- 06 Occlusal interferences causing excessive lateral forces
- 07 Patient parafunctions such as bruxism
- 08 Inadequate dental laboratory casting procedures
- 09 Improper prosthesis fit
- 10 Trauma from patient habits or accidents
- 11 Excessive marginal bone loss caused by inadequate bone width and/or advanced periimplantitis

# Surgical Kit Maintenance

## Manual Cleaning and Sterilization Procedure

It is important to use protective clothing and face shield while cleaning contaminated instruments. Always wear protective glasses, mask, gloves, etc. for your safety.

## Cleaning

- 1 Rinse instruments immediately after use under running tap water (<40°C) for a minimum of one (1) minute to remove all debris including extraneous body fluids, bone debris and tissue.
- 2 Soak all instruments immediately after rinsing in an enzymatic cleaning solution\* for 10 to 20 minutes (Do not soak overnight).
  - \* Follow manufacturer's instructions and observe recommended cleaning solution concentrations (enzymatic detergent with a pH level between 7-10 and temperature not to exceed 40°C). Do not use incompatible cleaning solutions to clean instruments.
- 3 For internal irrigation drills, use a 1mL syringe and a 25 gauge needle to clean the drill irrigation hole with a minimum of 0.2 mL of the prepared cleaning solution. Repeat this step two (2) more times for a total of three (3) rinses.
- 4 Scrub with a soft brush for a minimum of 1 (one) minute to remove any debris inside the drill irrigation hole.
- 5 Rinse the instruments under running tap water (<40°C) for a minimum of 1 minute. Use a 1mL syringe and a 25 gauge needle with a minimum of 0.2 mL of tap water to forcefully flush inside the drill irrigation hole. Repeat flushing of drill irrigation hole two (2) more times for a total of three (3) flushings.
- 6 Place instruments into an ultrasonic cleaner with neutral detergent\*\*. Keep instruments inside the ultrasonic bath for 15 minutes using a frequency of 25-50 kHz. Ensure multiple instruments placed within the bath remain separated.
  - \*\* Follow manufacturer's instructions and observe recommended neutral detergent solution concentrations (neutral detergent with a pH level between 7-10 and temperature not to exceed 40°C). Do not use incompatible neutral detergent solutions to clean instruments.
- 7 Rinse instruments thoroughly with running tap water (<40°C) for a minimum of 1 (one) minute until all traces of neutral detergent solution are removed. Rinse inside drill irrigation hole using a 1mL syringe and a 25 gauge needle with a minimum of 0.2 mL of tap water. Repeat rinsing drill irrigation hole two (2) more times for a total of three (3) rinses.
- 8 Gently wipe instruments with a soft lint-free cloth or place the instruments in a drying cabinet (60°C for less than 10 hours) until fully dry. Blow residual water from drill irrigation hole using a 1mL syringe and a 25 gauge needle. Visually inspect instruments in a well-lit area to ensure they are clean, dry and free of residue.
- 9 Clean instrument trays with a germicidal cleaner prior to returning instruments into Kit.
- 10 Always check for damage or corrosion after rinsing and drying.

## Sterilization

Dentium recommends either the Pre-vacuum or Gravity autoclave methods for sterilization under the conditions described below. However, autoclave performance can affect the efficacy of this process. Healthcare facilities should validate their sterilization processes employing the actual equipment and operators that routinely sterilize instruments.

All autoclaves/sterilizers should be regularly validated, maintained and checked in accordance with EN 285/EN 13060, EN ISO 17665, ANSI AAMI ST79 to ensure compliance with these and related standards. Make sure packaging is suitable for steam sterilization.

## Recommended Sterilization Parameters

Method-Moist Heat Sterilization	Pre-vacuum	Gravity
<b>Set Point Temperature</b>	132 °C	132 °C
<b>Exposure time</b>	4 minutes	30 minutes
<b>Drying time</b>	20 minutes	40 minutes

# PROSTHESIS MANUAL

## Understanding the Implant and Prosthesis

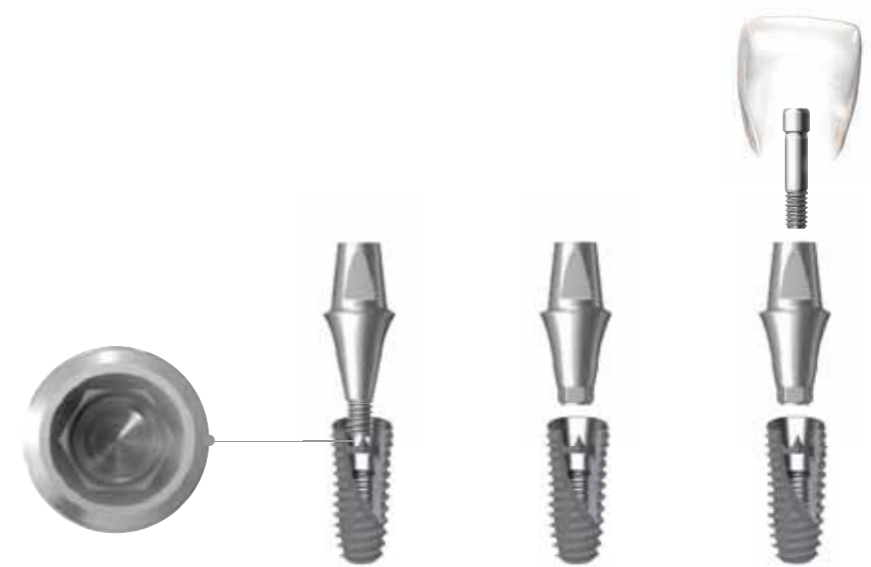

### Biological Connection

- The tapered conical hex connection between implant and abutment interface provides hermetic sealing.
- The biological connection distributes the load to the fixture evenly. Therefore it may minimize bone loss.
- All implant diameters share the same internal connection. One abutment screw fits all abutments and fixtures.







### Types of Abutment (Abutments are available in various diameters & gingival heights)

- |   |     |                                 |
|---|-----|---------------------------------|
| · Dual Abutment                           | [ ] | Abutment level                  |
| · Combi Abutment                          |     |                                 |
| · Dual Abutment                           | [ ] | Fixture level                   |
| · Dual Milling Abutment                   |     |                                 |
| · Angled Abutment (15°/25°)               |     |                                 |
| · Direct-Casting Abutment                 |     |                                 |
| · Metal-Casting Abutment                  |     |                                 |
| · Temporary Abutment (Plastic & Titanium) |     |                                 |
| · Screw Abutment                          | [ ] | Screw retained (Abutment level) |
| · Angled Screw Abutment (15°/ 30°)        |     |                                 |
| · Positioner Attachment                   | [ ] | For denture use                 |
| · Ball Attachment                         |     |                                 |
| · Magnetic Attachment                     |     |                                 |



# Types of Abutment

One-Piece	Two-Pieces	
 <p>Combi Abutment</p>	 <p>Hex Non-hex Dual Abutment</p>	 <p>Hex Non-hex Milling Abutment</p>
 <p>Screw Abutment</p>	<p>(15°)</p>  <p>Hex Non-hex Angled Abutment</p>	 <p>Custom Abutment</p>
<p>(20°)</p>  <p>Hex Non-hex Angled Screw Abutment</p>	<p>(25°)</p>  <p>Hex Non-hex Angled Abutment</p>	 <p>Hex Non-hex Direct-Casting Abutment</p>
 <p>Cylinder</p>	 <p>Hex Non-hex Metal-Casting Abutment</p>	<p>Titanium Plastic</p>  <p>Hex Non-hex Hex Non-hex Temporary Abutment</p>
Abutment Level	Fixture Level	

- Straight abutments are Dual and Combi Abutment.
- Depending on the insertion angle and position of the fixture, the Angled or Direct / Metal - Casting Abutment may be used.
- The Screw Abutment can be used when prosthesis retrieval is anticipated.

# Dual Abutment

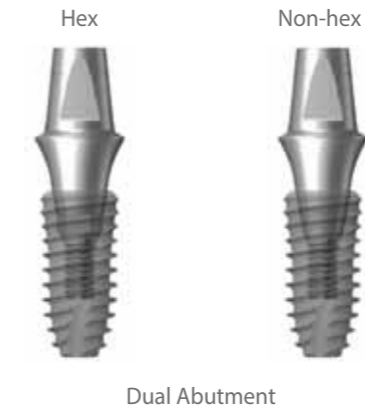

- It is possible to take an impression at both fixture level and abutment level. (A Dual Abutment may be interchanged with a Combi Abutment)
- For abutment level impressions, the same prosthetic procedures apply to both Dual and Combi Abutments.
- For fixture level impressions, the abutment selection takes place on the master model.
- For fixture level impressions, a precise positioning jig for abutment may be required.
- Either hex or non-hex abutments may be used, according to operator's preference.

\* If a cement retained restoration requires retrieval, cutting a hole in the occlusal surface would allow access to the screw to permit removal.

## Hex / Non-hex

	Hex	Non-hex
Positioning Jig	Unnecessary	Required
Radiograph	Unnecessary	Unnecessary

## Dual Abutment Line Up (Hex / Non-hex)

Diameter	G/H	Vertical Angle
Ø4.5	1.0mm, 1.5mm, 2.5mm, 3.5mm, 4.5mm, 5.5mm	5°
Ø5.5	1.5mm, 2.5mm, 3.5mm, 4.5mm, 5.5mm	6°
Ø6.5	1.5mm, 2.5mm, 3.5mm, 4.5mm, 5.5mm	7°



# Combi Abutment

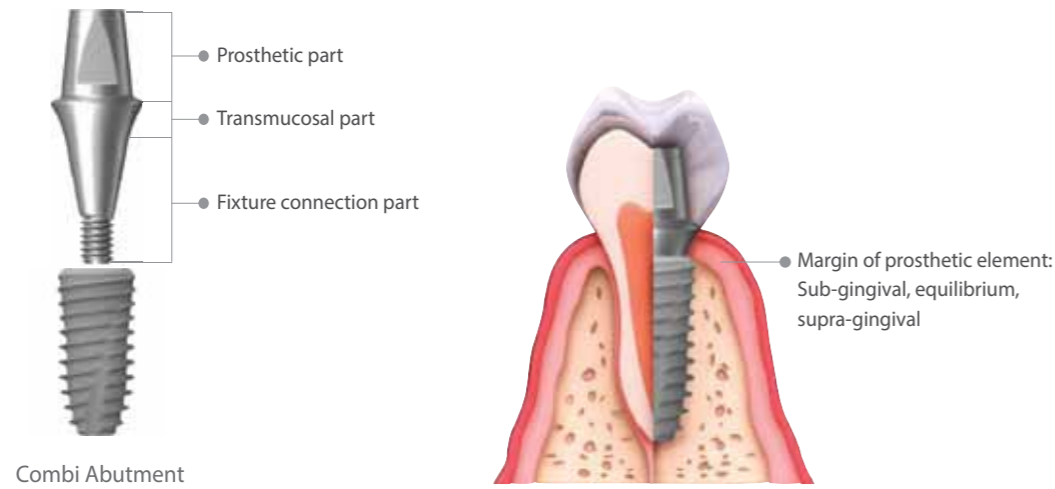

- The Combi Abutment is used when the implant position is optimal.
- If the abutment selection is made in the mouth, gauge the thickness of mucosa with the depth gauge to measure the gingival height thus allowing the appropriate abutment height.
- The Impression is taken with the snap cap.
- When using the Combi Abutment, it remains in the mouth after the impression is taken. (Do not remove or change its position)
- Tighten abutment screw to 25 - 35 N-cm. (retighten again before seating final prosthesis).

\* If the Combi Abutment is too long it can be adjusted 1.5mm to the bottom of the laser mark on the vertical stack of the abutment. The Combi Abutment has a short analog for the 1.5mm adjustment.

\* A resin jig can be made to record the reduction if reduced more the 1.5mm.

## Combi Abutment Line Up

Diameter	G/H	Vertical Angle
Ø4.5	1.0mm, 1.5mm, 2.5mm, 3.5mm, 4.5mm, 5.5mm	5°
Ø5.5	1.5mm, 2.5mm, 3.5mm, 4.5mm, 5.5mm	6°
Ø6.5	1.5mm, 2.5mm, 3.5mm, 4.5mm, 5.5mm	7°



# Custom / Milling Abutment

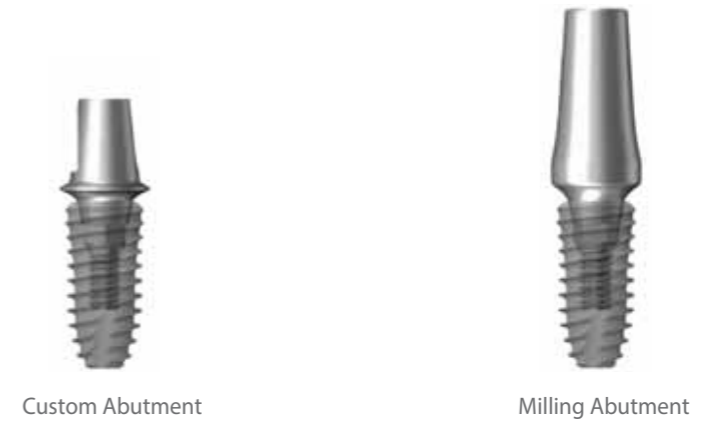

## Custom Abutment

- Impression is taken at fixture level.
- When using a non-hex abutment a precise seating jig should be used.

Diameter	G/H	Type
Ø4.5	0.5mm, 1.5mm	Hex / Non-hex
Ø5.5	1.0mm, 2.0mm	



## Milling Abutment

- Impression is taken at fixture level.
- When using a non-hex abutment a precise seating jig should be used.
- Either hex or non-hex abutments may be used, according to operators preference.

\* If a cement retained restoration requires retrieval, cutting a hole in the occlusal surface would allow access to the screw for removal.

Diameter	G/H	Type
Ø4.0	1.0mm	Hex / Non-hex
Ø4.5	1.5mm	
Ø5.5	1.5mm, 2.5mm	
Ø6.5	1.5mm, 2.5mm, 3.5mm	
Ø7.5	2.5mm, 3.5mm	



# Angled Abutment

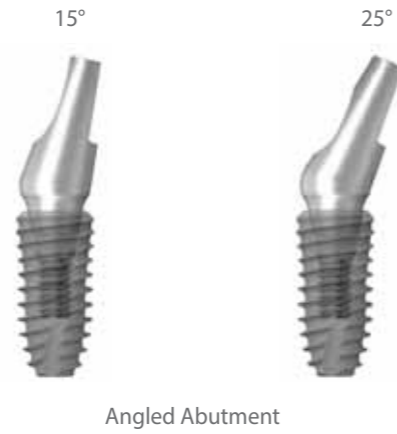

Angled Abutment

- The Angled Abutment is recommended when the restoration path of insertion is unfavorable in either anterior or posterior sites.
- Retention force can be increased through milling process.



## Angled Abutment Line Up

Diameter	G/H	Angle
Ø4.5	1.5mm 2.5mm 3.5mm	15° / 25°
Ø5.5	1.5mm 2.5mm 3.5mm	

# Direct-Casting / Metal-Casting Abutment



Direct-Casting Abutment

Metal-Casting Abutment

## Direct-Casting Abutment

- Excellent for either single or bridgework
- Used as an esthetic custom made abutment.
- Used when angulation is not ideal and a standard abutment cannot be used.
- Used when there is inadequate inter-arch distance and a standard abutment cannot be used.
- A fixture level impression is taken, and the soft tissue contours can be supported.

Diameter	G/H	Type
Ø4.5	1.0mm	Hex / Non-hex



## Metal-Casting Abutment

- Equivalent results for a fraction of the price
- Our highly affordable metal alloy replaces expensive gold to alleviate financial burden to all.

Diameter	G/H	Type
Ø4.5	1.0mm	Hex / Non-hex



# Temporary Abutment



Ti-Temporary Abutment



Plastic Temporary Abutment

## Temporary Abutment

- Temporary Abutments are available with titanium or plastic.
- The titanium abutment comes in both hex and non-hex with a gingival height of 1.0mm.
- The plastic abutment comes in diameters (Ø4.5, 5.5, 6.5) with a gingival height of 2.0mm.

Abutment	Diameter	G/H	Type
Ti-Temporary	Ø4.5	1.0mm	Hex / Non-hex
Plastic Temporary	Ø4.5	2.0mm	Hex / Non-hex
	Ø5.5		
	Ø6.5		

# Screw Abutment



Screw Abutment



Angled Screw Abutment

**If prosthesis repair is anticipated, use of a Screw Abutment retained prosthesis enables easy retrieval.**

- Useful for connecting multiple units or when there is a preference for a screw retained prosthesis.
- Useful when respective long axes of implants differ. Each side tapers by 30° and this permits up to 60° divergence between two abutments.
- Useful when the prognosis of an adjacent restoration is not ideal thus permitting easy retrieval and modification of the restoration.

## Ti-Retaining Screw (1.8mm - body diameter)

- Can minimize screw loosening due to increased approximal space.
- Can endure various kinds of masticatory force.

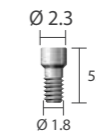

## Screw Abutment Line Up

Diameter	G/H
Ø4.5	1.0mm, 1.5mm, 2.5mm, 3.5mm, 4.5mm, 5.5mm
Ø5.5	1.5mm, 2.5mm, 3.5mm, 4.5mm, 5.5mm

## Angled Screw Abutment Line Up

Diameter	G/H	Angle
Ø4.5	1.0mm 2.0mm 3.0mm	20°
Ø5.5	1.0mm 2.0mm 3.0mm	



# Points to Consider in Abutment Selection

## Considerations in Selecting an Abutment

- Esthetic requirement
- Implant angulation
- Implant location
- Fixture installation depth (Gingival height)
- Interarch distance
- Prosthesis type
- Dentist & dental technician's preference

## Impression of Implant

According to the case the impression can be taken at abutment or fixture level.

Fixture Level	Abutment Level
1. Dual Abutment	1. Dual Abutment
2. Dual Milling Abutment	2. Combi Abutment
3. Angled Abutment (15° / 25°)	3. Screw Abutment
4. Direct-Casting Abutment	4. Angled Screw Abutment (20°)
5. Metal-Casting Abutment	
6. Temporary Abutment (Plastic & Titanium)	

## Abutment Impression Recommendation

Abutment	Type	Impression
Dual Abutment	Cementation type, screw-cementation type	Fixture level impression or abutment level impression
Combi Abutment	Cementation type	Abutment level impression
Angled Abutment	Cementation type, screw-cementation type	Fixture level impression
Screw Abutment	Screw retained type	Abutment level impression
Direct-Casting Abutment	Cementation type, screw-cementation type	Fixture level impression
Metal-Casting Abutment	Cementation type, screw-cementation type	Fixture level impression
Dual Milling Abutment	Cementation type, screw-cementation type	Fixture level impression

# Minimum Height Requirement for SuperLine Prosthetic Abutment

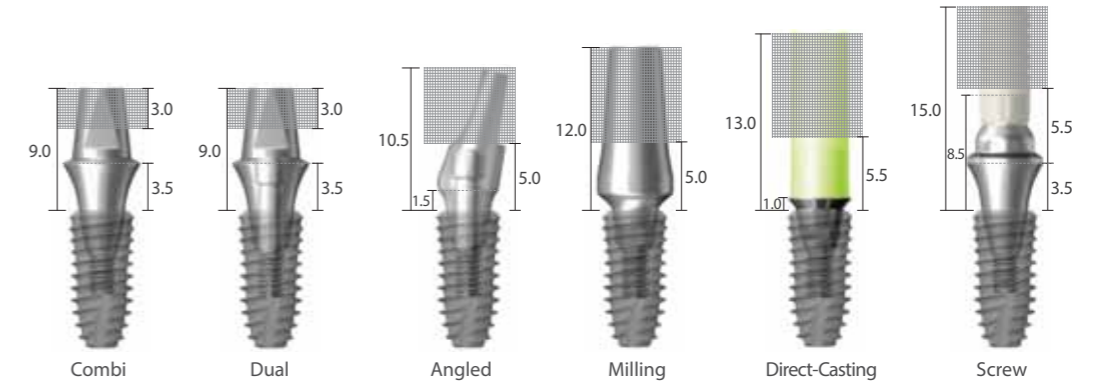

\* Diagram above indicates the minimum height required for SuperLine prosthetic abutment.

## Maximum Amount of Reduction Allotted for SuperLine

### Combi Abutment

- Eliminate 3.0mm from the top level Combi Abutment (laser marking: 1.5mm)
- Caution \_ Damage may be caused to the screw if the abutment is reduced to less than 2.5mm above the gingival height.

### Dual Abutment

- Preparation of the abutment top is possible as follows.

Gingival Height	Preparable Amount
1.5mm	2.0
2.5mm	3.0
3.5mm	4.0
4.5mm	5.0
5.5mm	6.0

### Angled Abutment & Milling Abutment

- Preparation of the abutment top is possible as follows.

### Direct-Casting Abutment & Metal-Casting Abutment

- Required minimum abutment height: at least 5.5mm above the Fixture top.

### Direct-Casting Abutment & Metal-Casting Abutment

- The Screw Abutment cannot be modified, however the Casting Abutment can be modified for interarch distance, taking reduction into consideration of the height of the retaining screw.

# Prosthetic Procedure 1

Impression Technique and Restoration Selection

## Dual / Combi Abutment

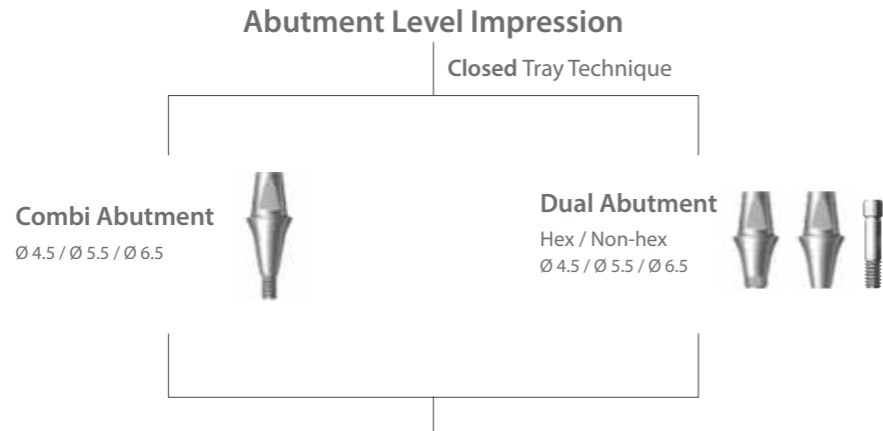

## Impression Coping

Transfer (Snap on)  
Ø 4.5 / Ø 5.5 / Ø 6.5

## Analog

Long  
Ø 4.5 / Ø 5.5 / Ø 6.5

## Analog

Short  
Ø 4.5 / Ø 5.5 / Ø 6.5

## Burn-out Cylinder

## Bridge

Rotational  
Ø 4.5 / Ø 5.5 / Ø 6.5

## Single

Non-rotational  
Ø 4.5 / Ø 5.5 / Ø 6.5

## Modification

## Cemented Restoration

# Abutment Level\_Dual Abutment

[Multiple Units]

## Clinical Procedure

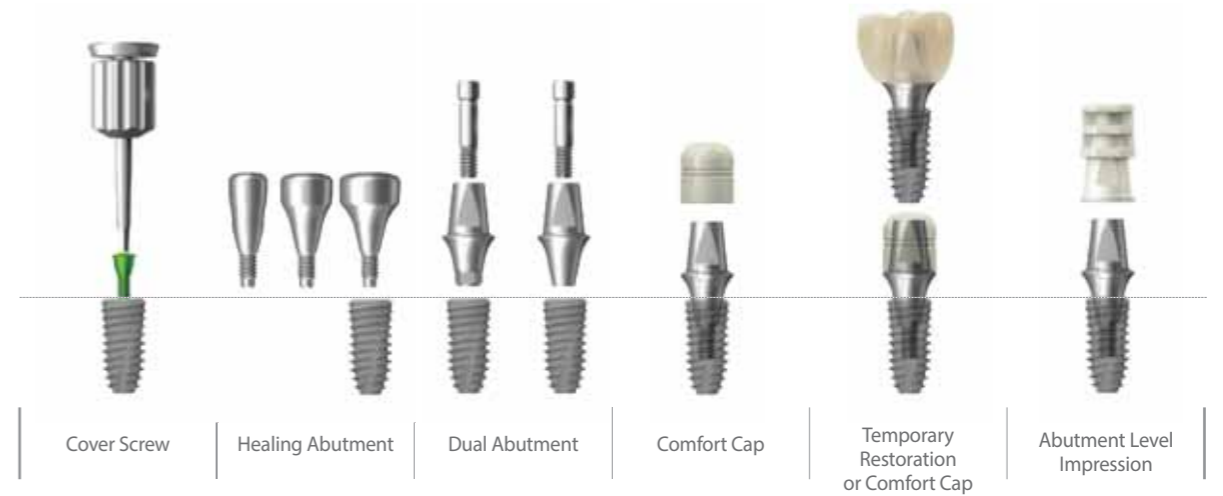

## Chairside

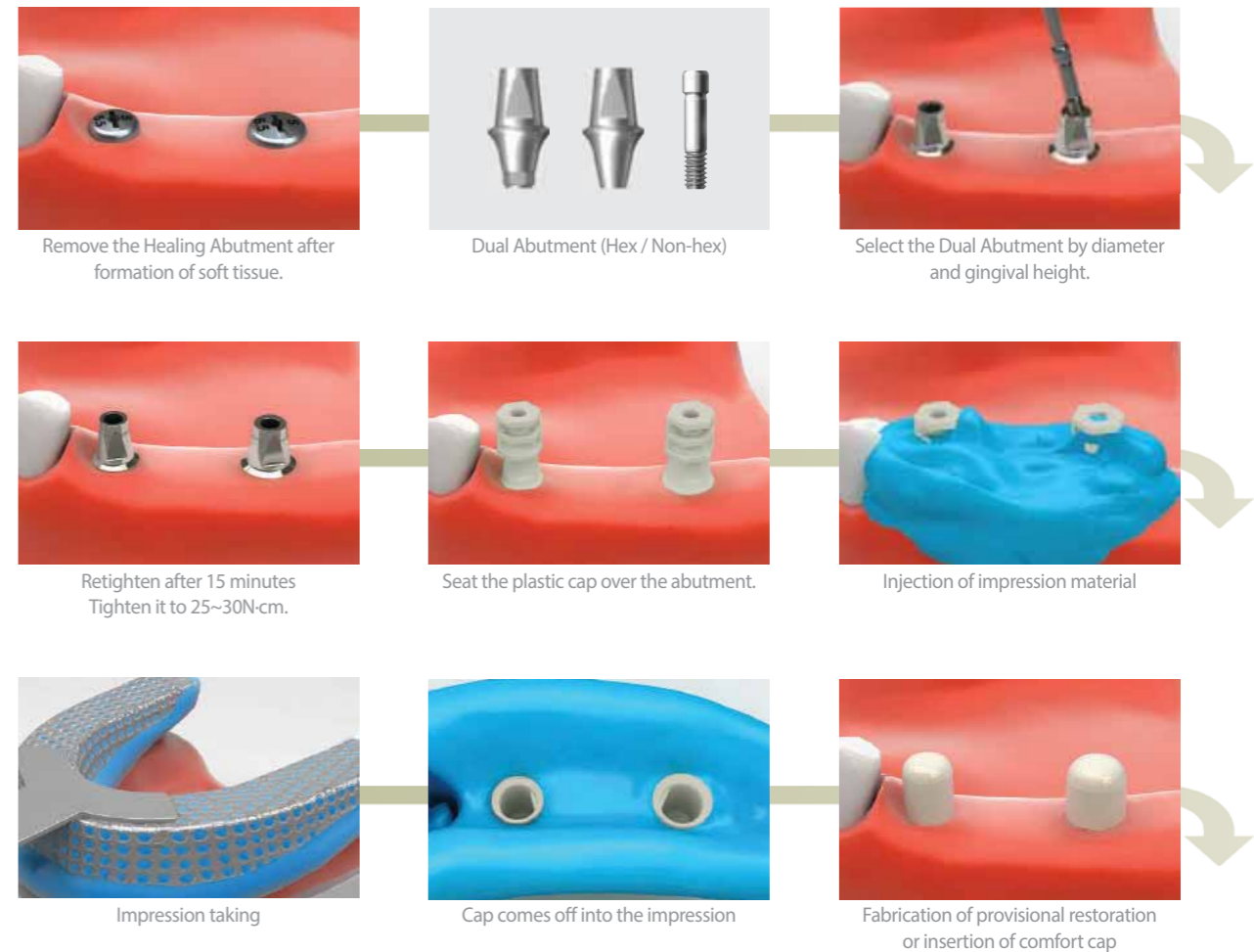

# Abutment Level\_Dual Abutment

[Multiple Units]

## Clinical Procedure



## LabSide

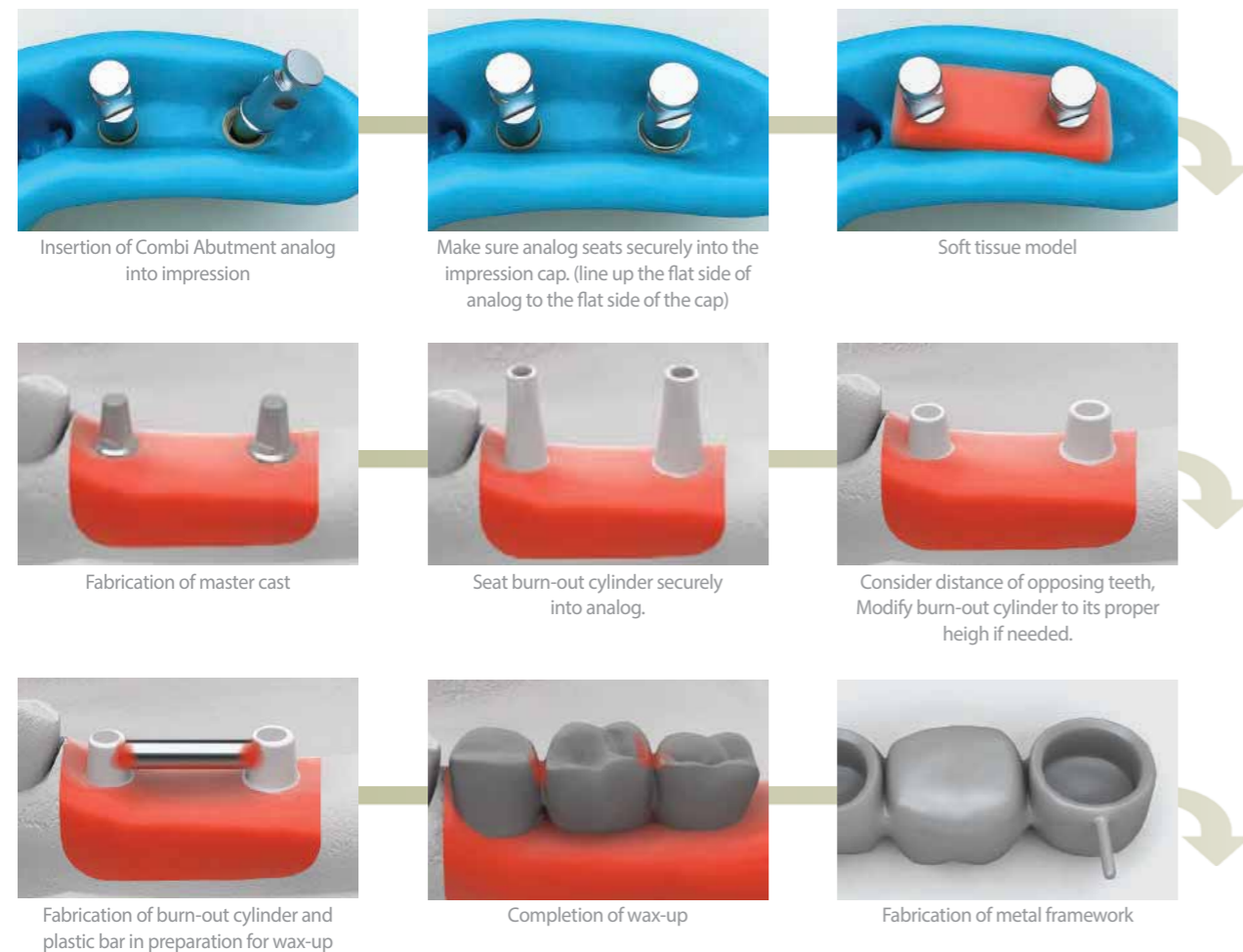

# Abutment Level\_Dual Abutment

[Multiple Units]

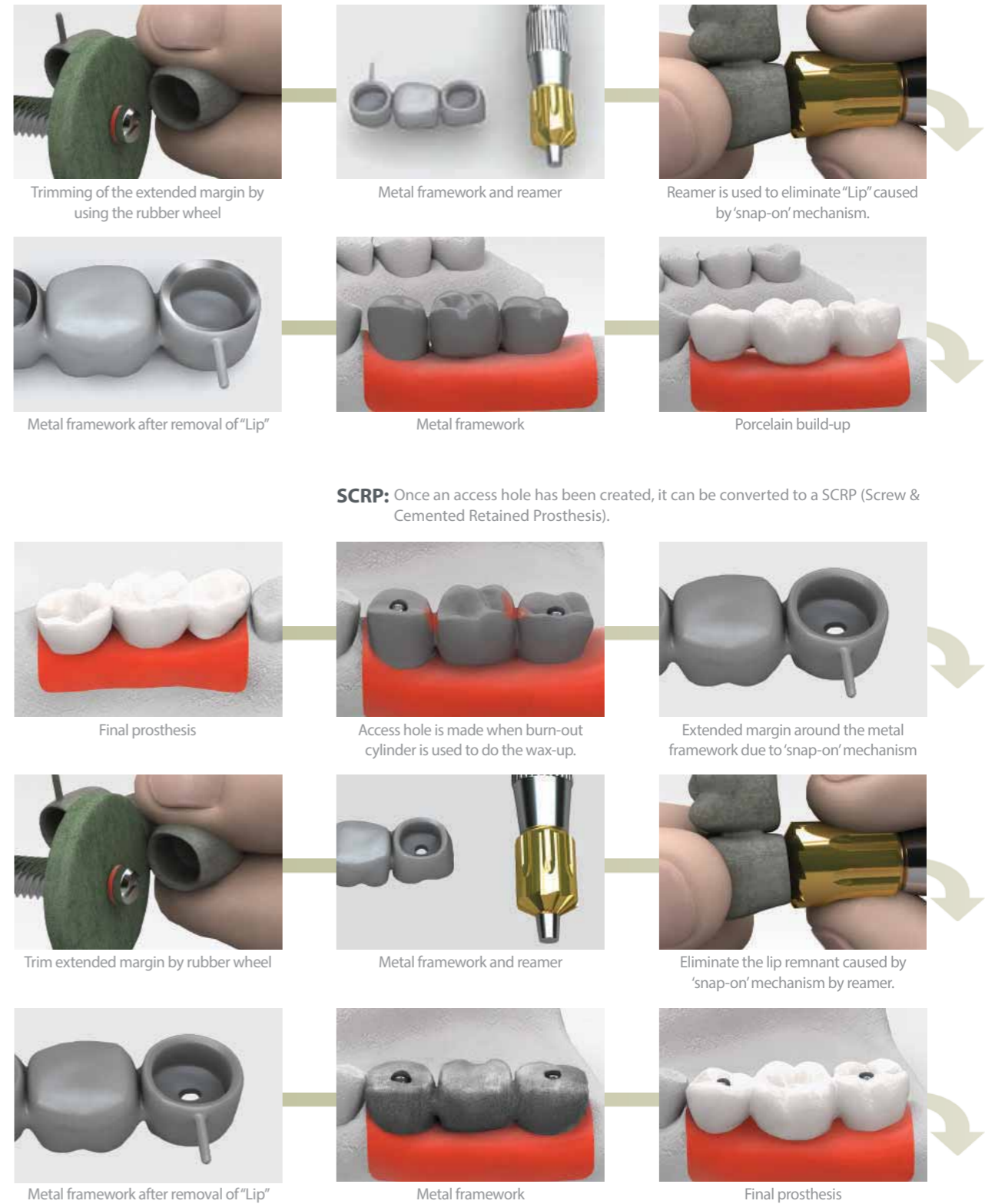

# Abutment Level\_Combi Abutment

[Multiple Units]

## Chairside

Second stage surgery (uncovering)

Following the 2nd stage surgery, soft tissue is healed around the Healing Abutment. Healing Abutment should be selected according to the size of abutment.

Choose abutment with gingival height then tighten it to 25~30N-cm. Re tighten after 15 minutes.

Image of combi Impression coping and abutment assembly

Snap-on the plastic impression coping with the same sized diameter abutment

Impression taking  
Injection of impression material

Impression taking

Inner-surface of impression

Extended margin around the metal framework due to 'snap-on' mechanism

## Chairside

Seating of Lab analog

Confirm analog is secured in snap cap

Soft tissue model

Fabrication of master cast

Placement of burn-out cylinder

Consider the distance of opposing teeth, modify burn-out cylinders to its proper height.

# Abutment Level\_Combi Abutment

[Multiple Units]

Connect the plastic bar in the middle of the trimmed burn-out cylinders to help support the resin pattern. Wax pattern may have shrinkage.

Wax-up

Completed framework

Trimming the extended margin with a rubber wheel

Metal framework and reamer

Removal of lip remnant with reamer caused by 'snap-on' mechanism

Metal Framework after removal of "Lip"

Metal coping adaptation (Completed framework)

Porcelain build-up final prosthesis

## Chairside

Insertion of final prosthesis and occlusal adjustment

\* If the combi analog is trimmed due to limited inter-occlusal space in the lab, make a reduction jig. Then a slight modify of the abutment in the oral cavity may be necessary to the height of the jig.



# Prosthetic Procedure 2

Impression Technique and Restoration Selection

Dual / Custom / Milling / Angled / Direct-Casting / Metal-Casting /  
Ti-Temporary / Plastic Temporary Abutment

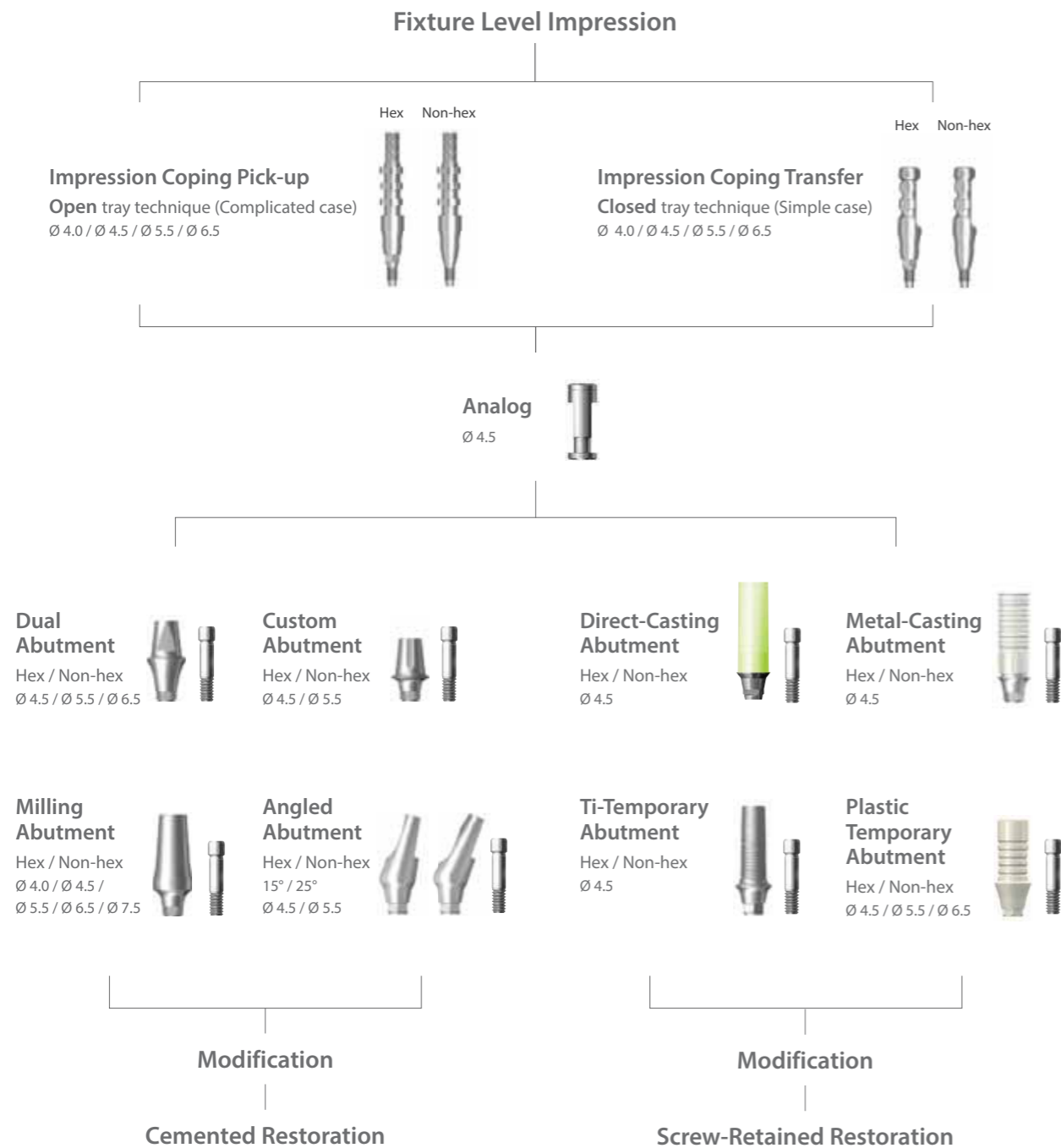

# Fixture Level [Pick-up Type]\_Dual Abutment

[Multiple Units]

## Clinical Procedure



## LabSide

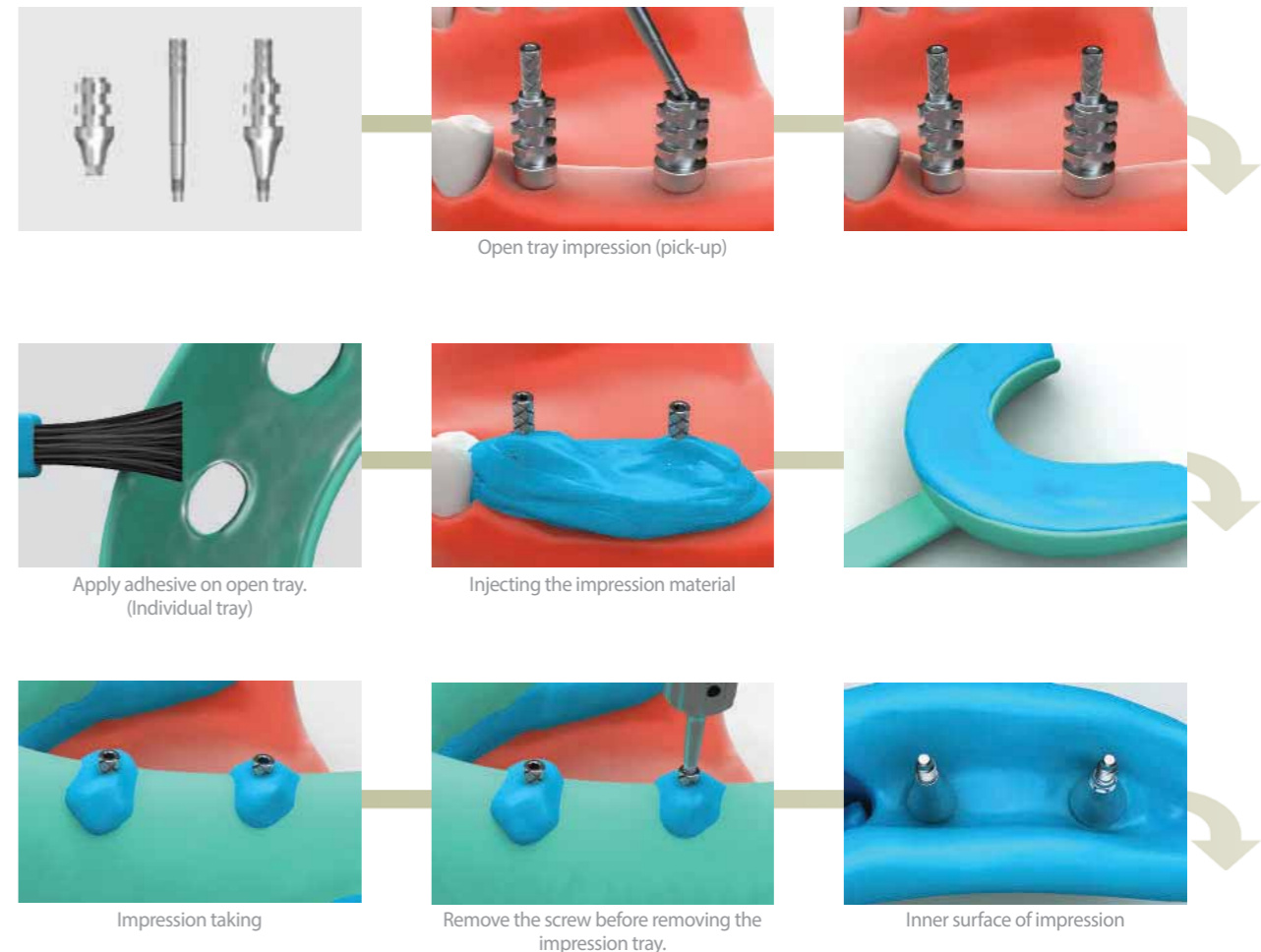

# Fixture Level [Pick-up Type]\_Dual Abutment

[Multiple Units]

## Clinical Procedure



## LabSide

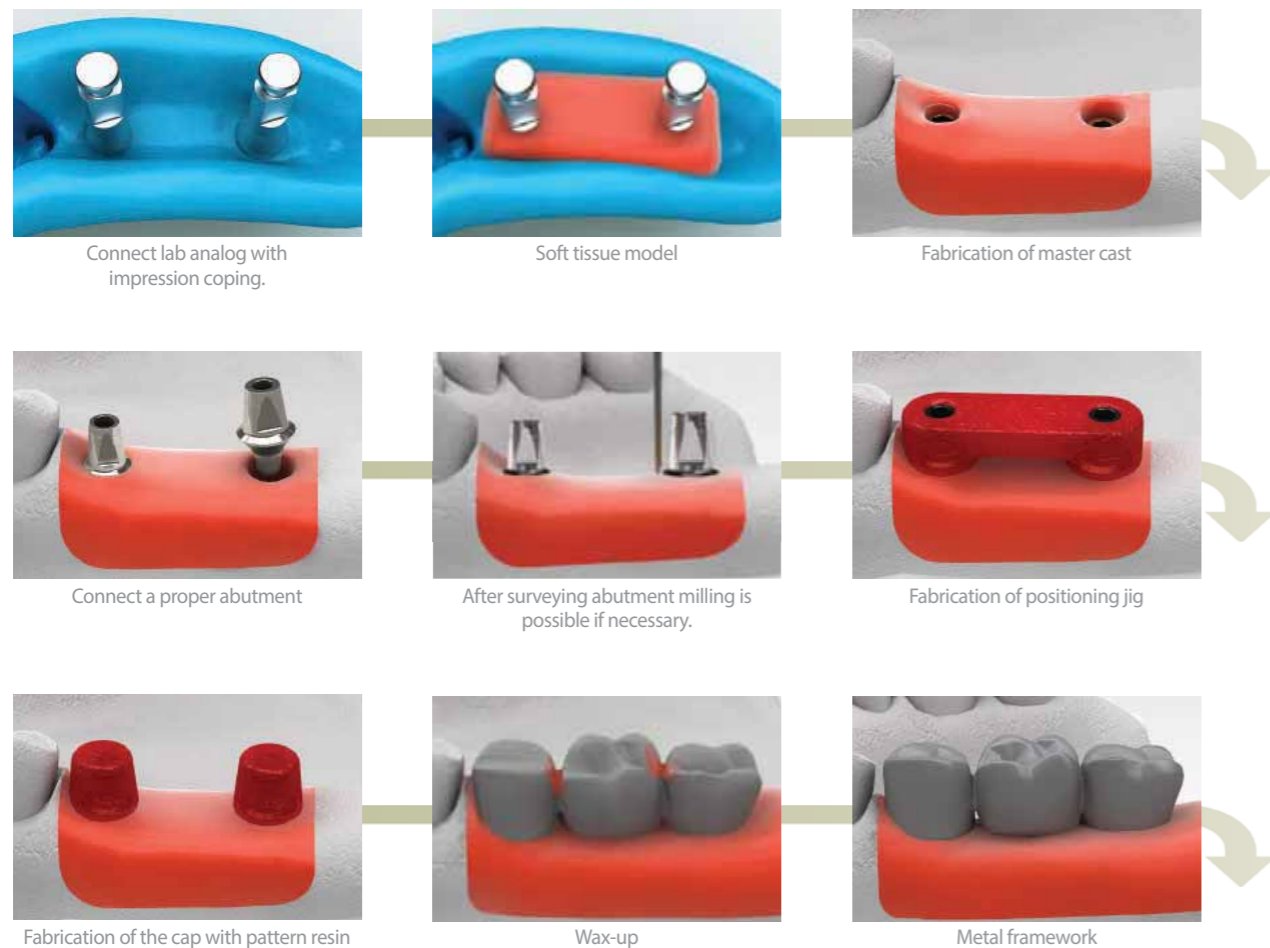

# Fixture Level [Pick-up Type]\_Dual Abutment

[Multiple Units]

## Chairside



## SCR- Labside



## SCR- Chairside



# Fixture Level [Transfer Type]\_Dual Abutment

[Multiple Units]

## Clinical Procedure

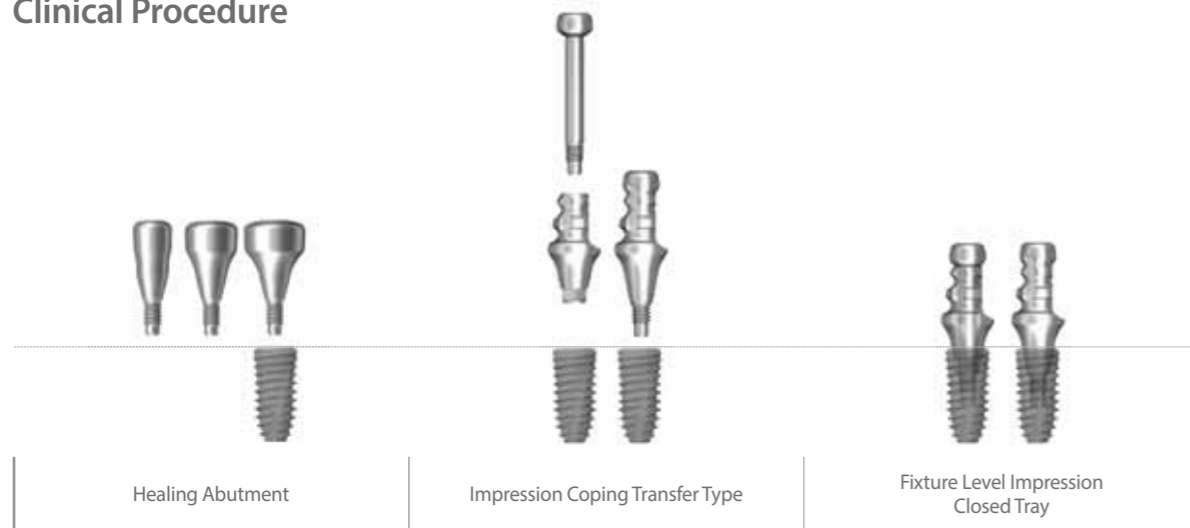

## Chairside

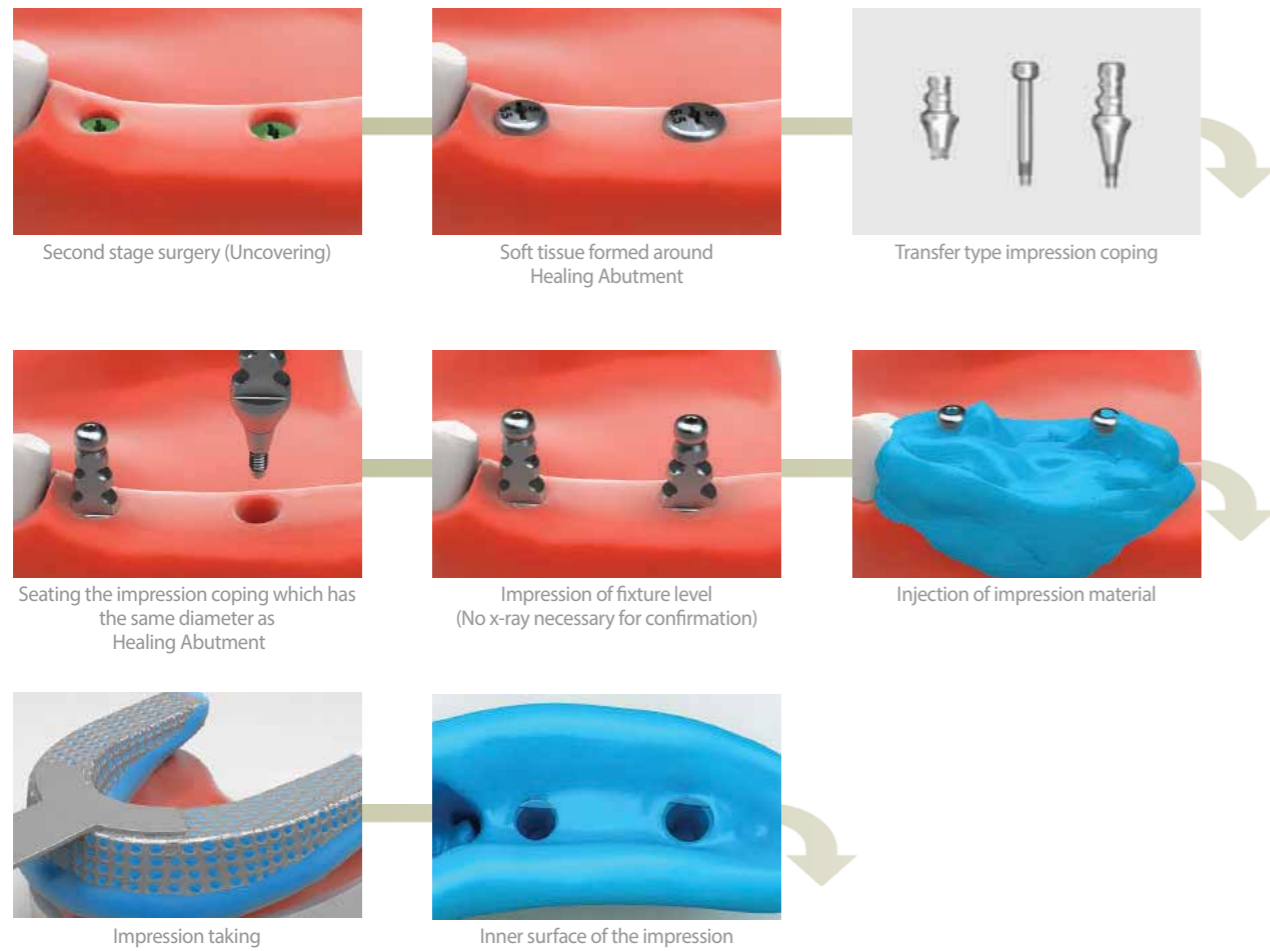

# Fixture Level [Transfer Type]\_Dual Abutment

[Multiple Units]

## Clinical Procedure



## LabSide

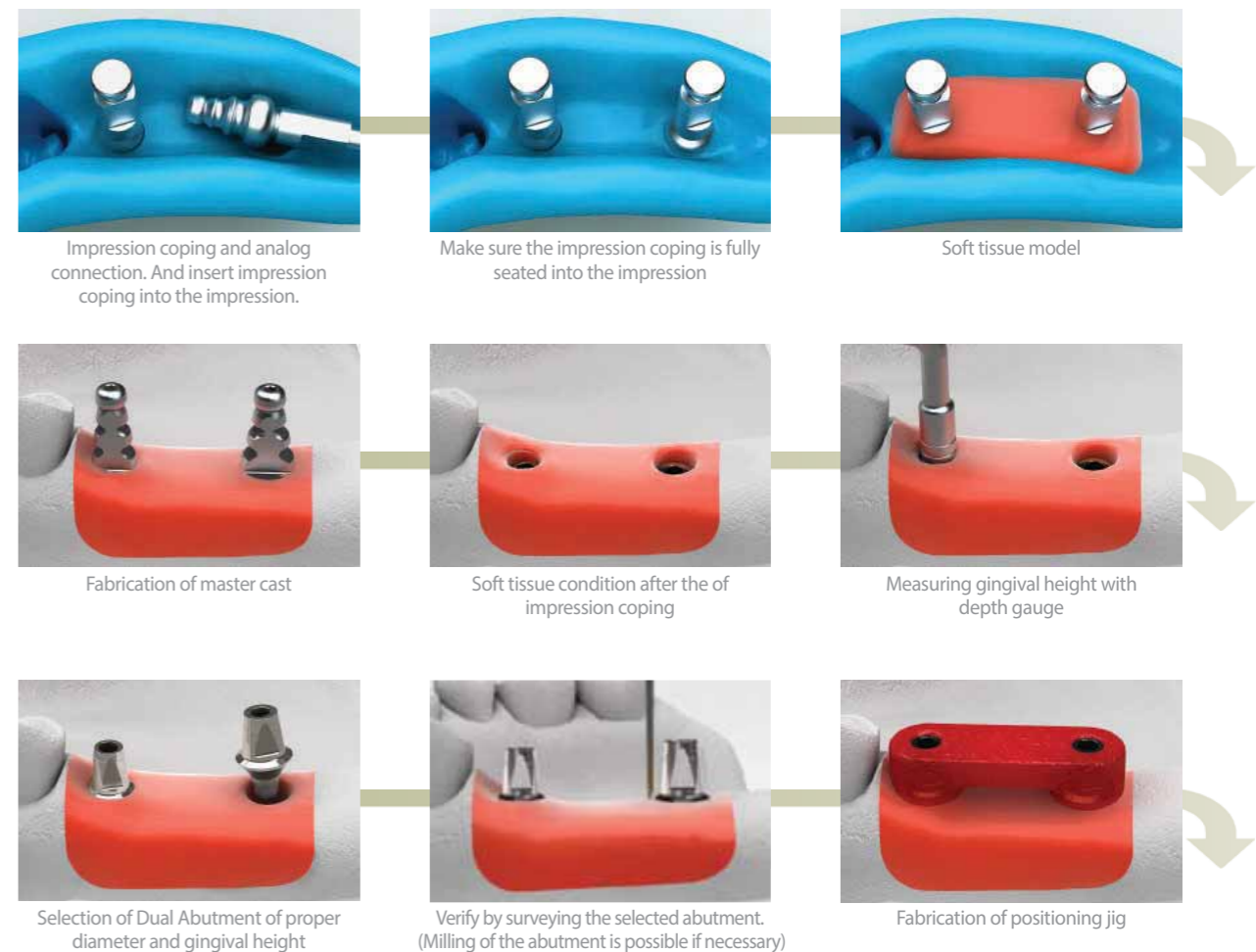

# Fixture Level [Transfer Type]\_Dual Abutment

[Multiple Units]



Seat the cap with pattern resin

Completion of wax-up

Completion of metal framework

## Chairside



Final prosthesis built up on the framework with porcelain

Use positioning jig to transfer the abutment in model to oral cavity then tighten it to 25~30N-cm. Retighten after 15 minutes.

Insertion of final prosthesis, adjust occlusion place lab wax into opening of abutment to protect screw head then cement.

## SCRP- Labside



Make an access hole in the resin cap by using the long open tray transfer screw.

Completed wax-up

Metal framework

## SCRP- Chairside



Final prosthesis built up on the framework with porcelain

Use positioning jig to transfer the abutment in model to oral cavity then tighten it to 25~30N-cm. Retighten after 15 minutes.

Insertion of final prosthesis and occlusal adjustment. Place wax into opening of the abutment prior to sealing with composite.

\* In the process of seating the prosthesis, the prosthesis can be rebounded by gingival tissue. In this case it is advised to apply occlusal load on the prosthesis for 10~15 minutes.

# Fixture Level [Transfer Type]\_Milling Abutment

[Single Unit]

## Clinical Procedure



## Chairside

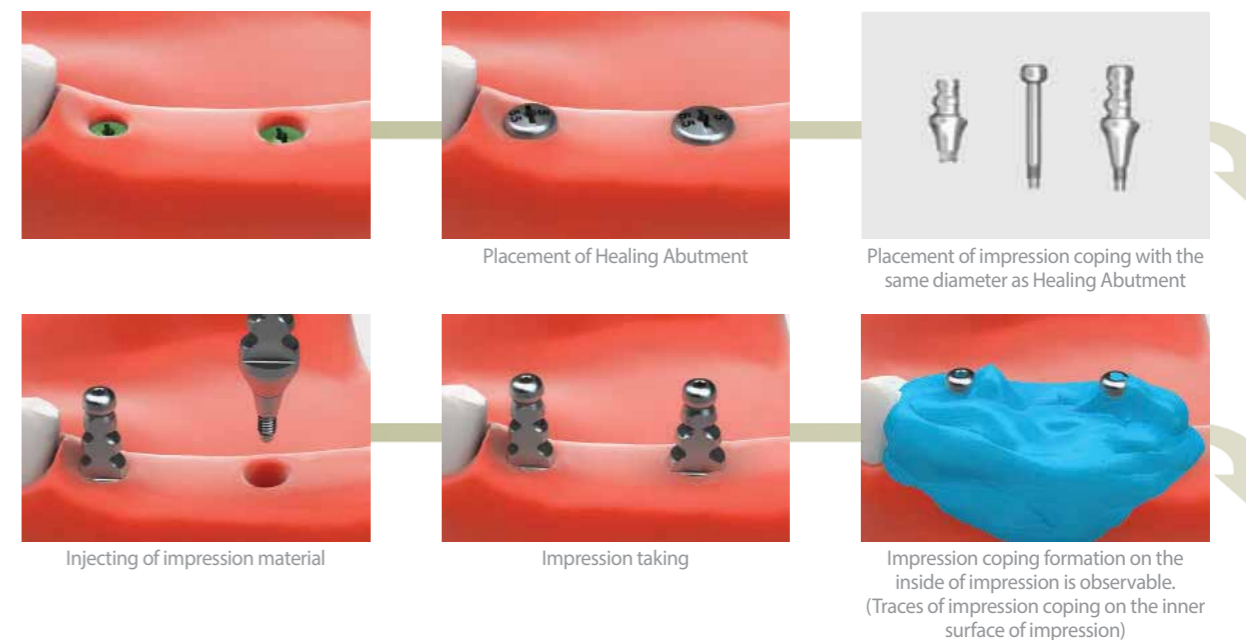

Injecting of impression material

Impression taking

Impression coping formation on the inside of impression is observable. (Traces of impression coping on the inner surface of impression)

## Laboratory Procedure



Lab Analog Connection

Milling Abutment Connection

Modification

Crown Wax-up

Final Restoration Cementation Type

# Fixture Level [Transfer Type]\_Milling Abutment

[Single Unit]

## Labside



Impression coping and analog connection. And insert impression coping into the impression.



Soft tissue model

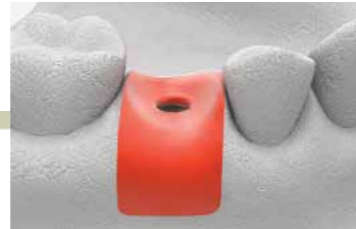

Master cast



Selection of appropriate Dual Milling Abutment



Abutment after milling process



Fabrication of positioning jig



Fabrication of pattern resin cap

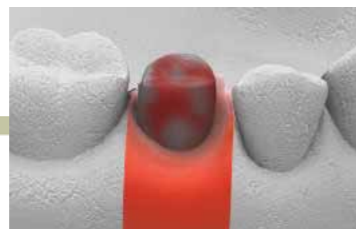

Completion of wax-up

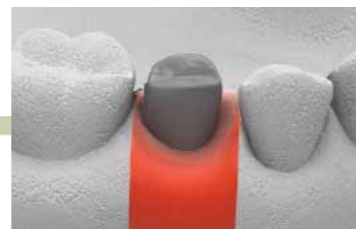

Metal framework

## Chairside



Final prosthesis



Use positioning jig to transfer the abutment in model to oral cavity then tighten it to 25~30N-cm. Retighten after 15 minutes.



Insertion of final prosthesis and occlusal adjustment

\* In the process of seating the prosthesis, the prosthesis can be rebounded by gingival tissue. In this case it is advised to apply occlusal load on the prosthesis for 10~15 minutes.

# Fixture Level [Pick-up Type]\_Angled Abutment

[Single Unit]

## Clinical Procedure



Angled Abutment



Impression Coping Pick-up Type



Fixture Level Impression

## Chairside



Pick-up type impression coping



Placement of pick-up impression



Injecting impression material



Impression taking (individual tray with holes)



Unscrew, then remove the impression.



Removed impression

## Laboratory Procedure



Lab Analog Connection



Angled Abutment Connection



Modification



Crown Wax-up



Final Restoration Cementation Type

# Fixture Level [Pick-up Type]\_Angled Abutment

[Single Unit]

## Labside

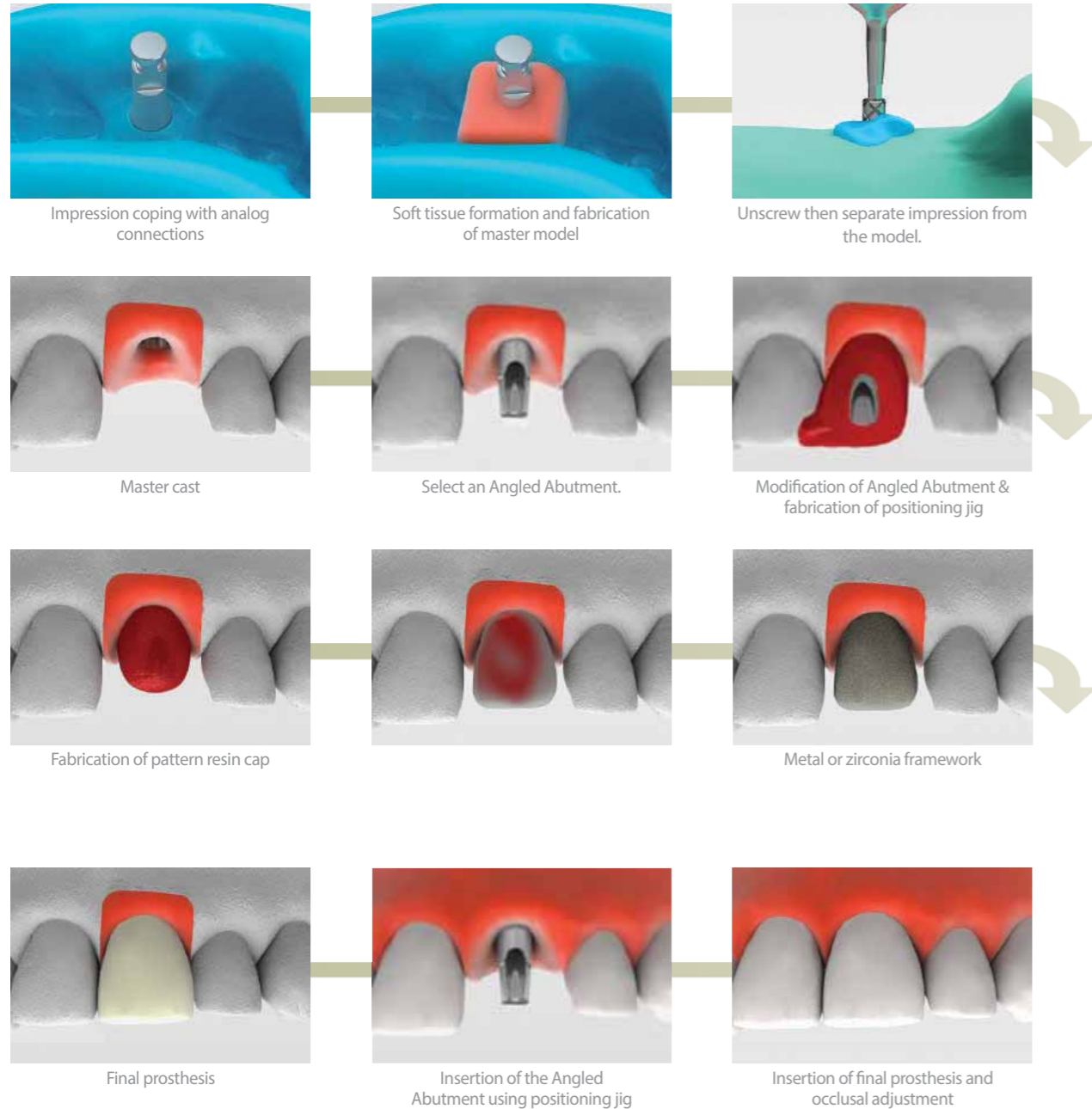

# Fixture Level\_Direct-Casting Abutment

[Single Unit]

## Laboratory Procedure



## LabSide

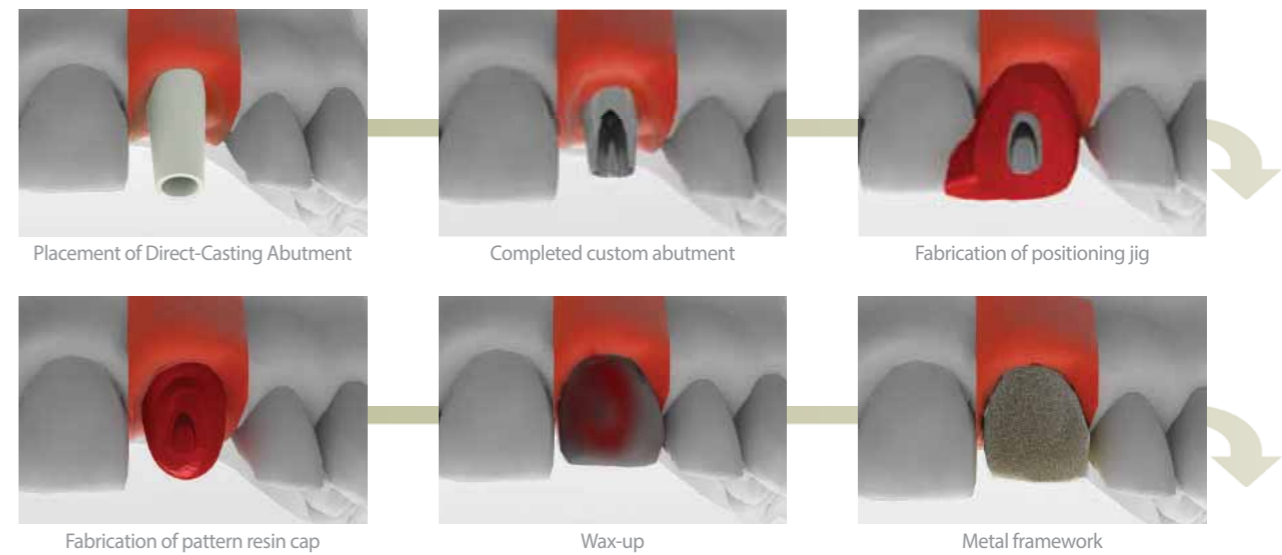

## Chairside



# Fixture Level\_Metal-Casting Abutment

[Single Unit]

## Laboratory Procedure

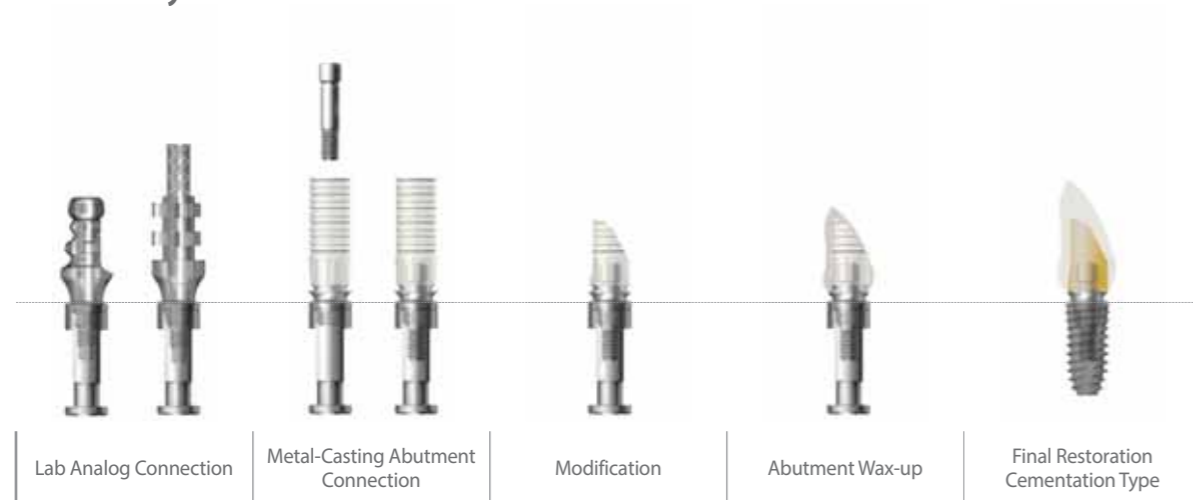

## LabSide

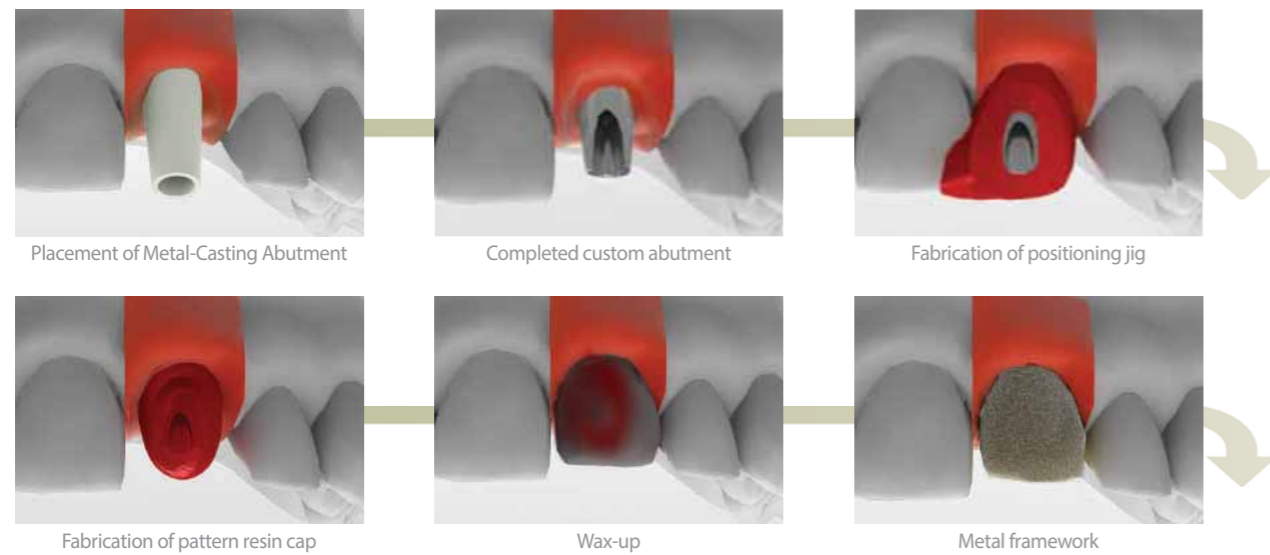

## Chairside

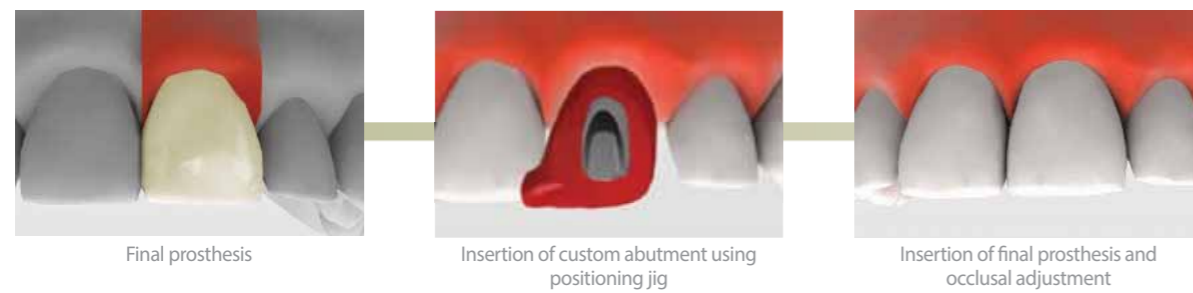

# Fixture Level [Pick-up Type]\_Temporary Abutment

[Single Unit]

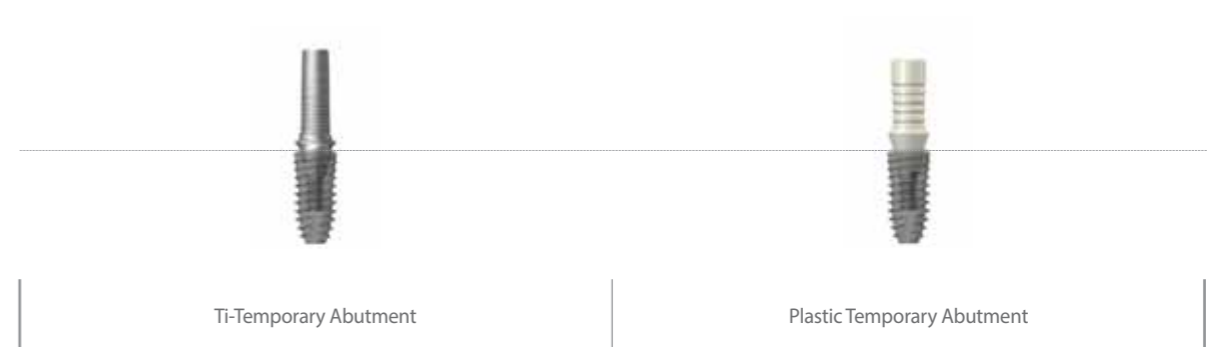

## <Using Ti Abutment>



Considering the opposing teeth before seating the Temporary Abutment, trim off the abutment as needed and complete the Temporary Abutment prosthesis with direct resin.

## <Using Plastic Abutment>



# Prosthetic Procedure 3

Impression Technique and Restoration Selection

## Screw Abutment

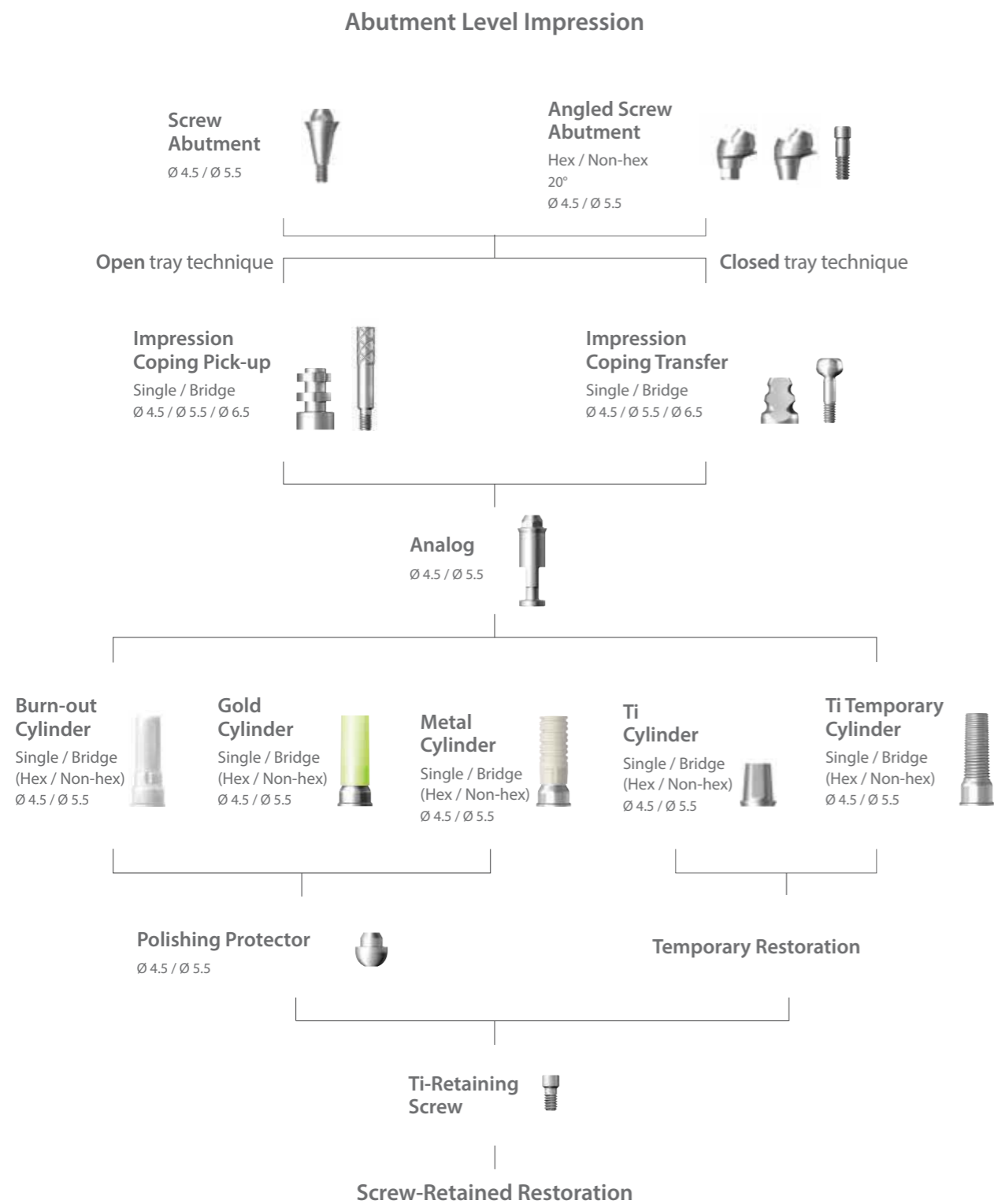

# Abutment Level [Transfer Type]\_Screw Abutment

[Multiple Units]

## Clinical Procedure

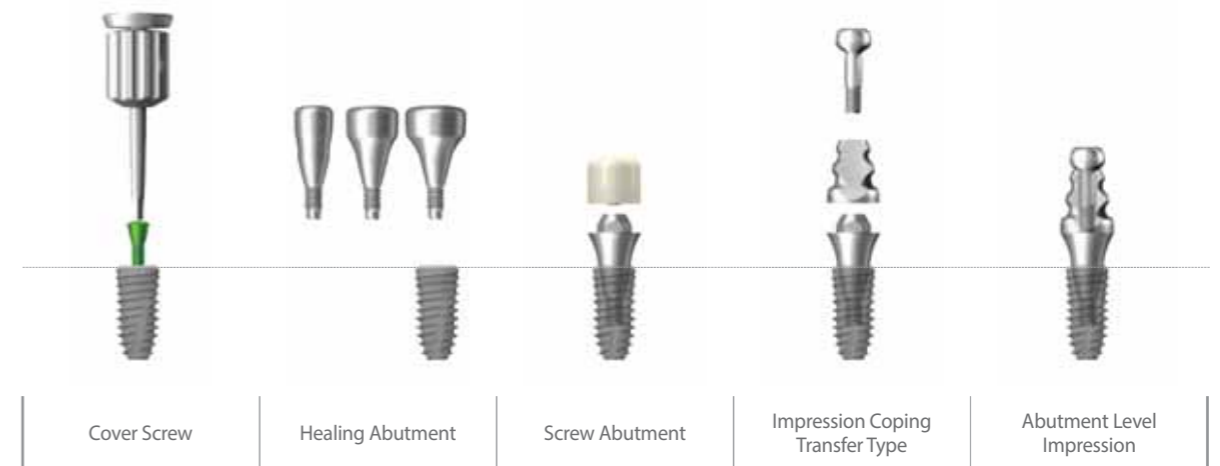

## LabSide

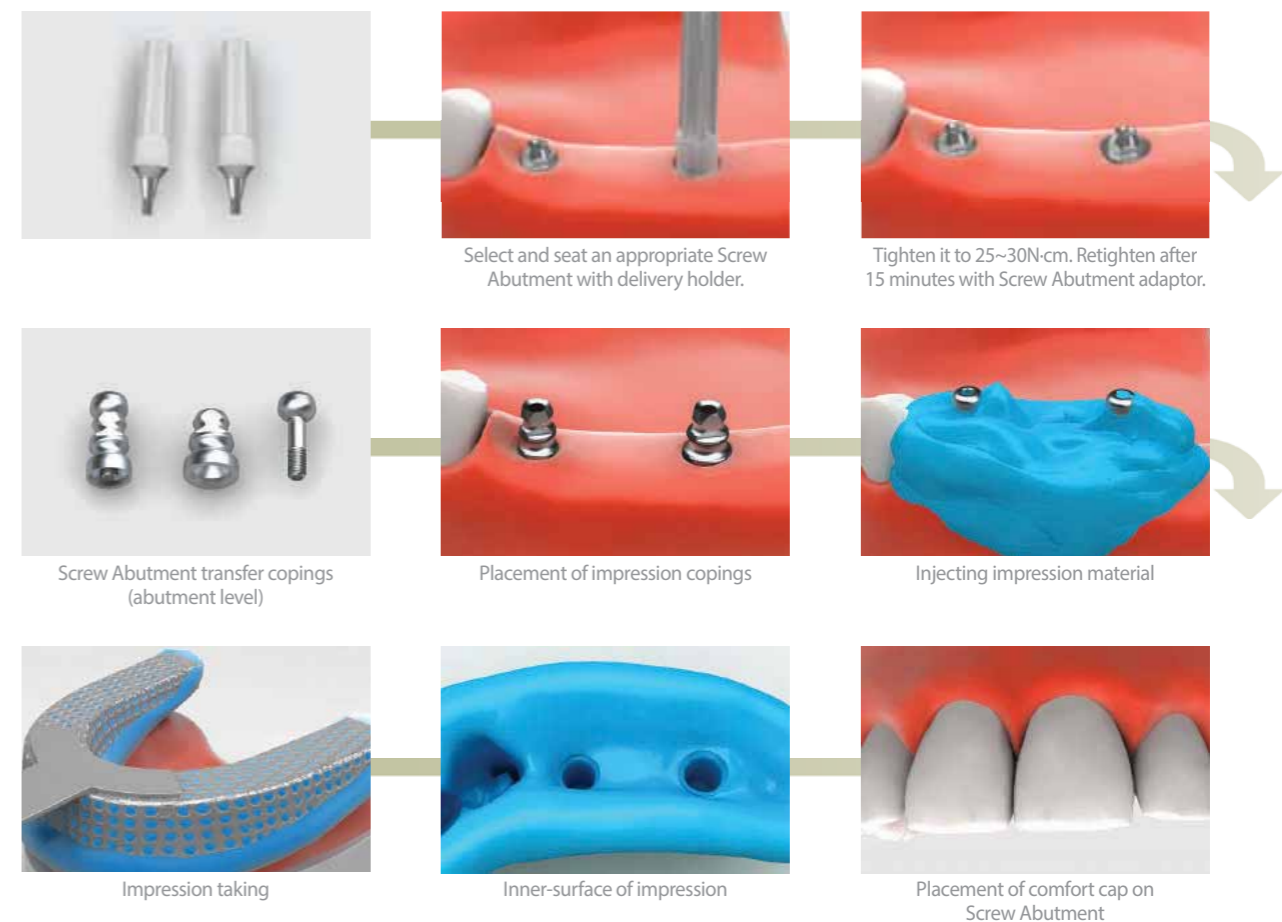



# Abutment Level [Transfer Type]\_Screw Abutment

[Multiple Units]

## Laboratory Procedure

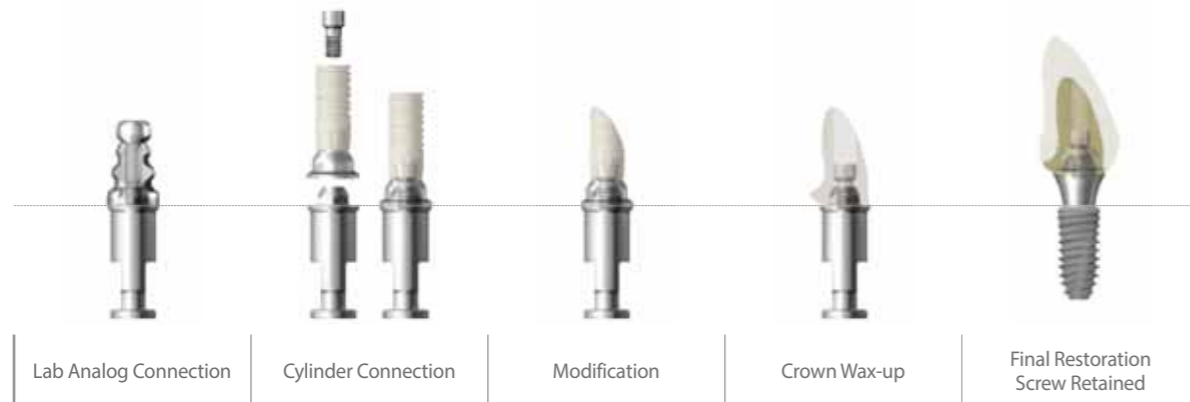

## LabSide

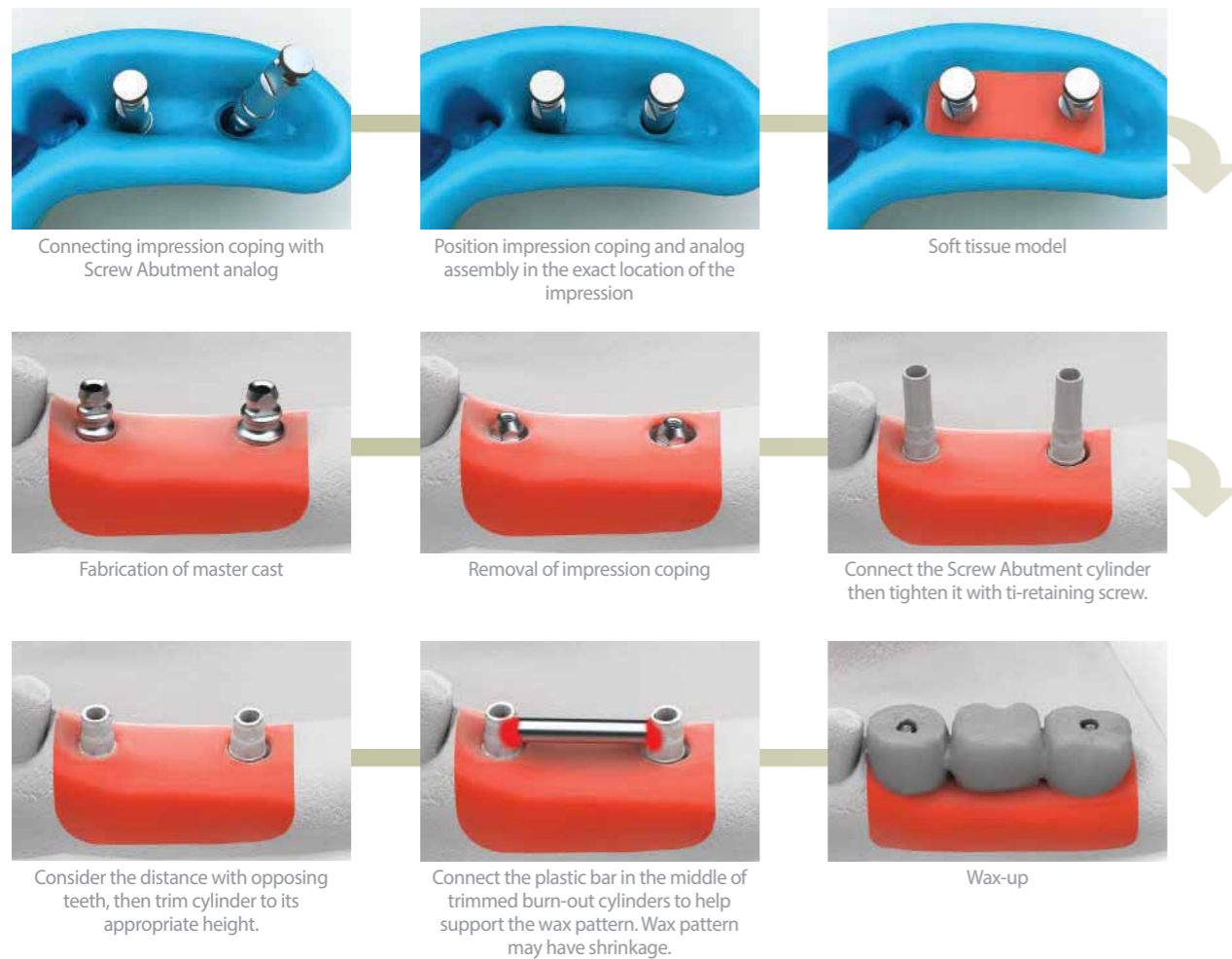

# Abutment Level [Transfer Type]\_Screw Abutment

[Multiple Units]

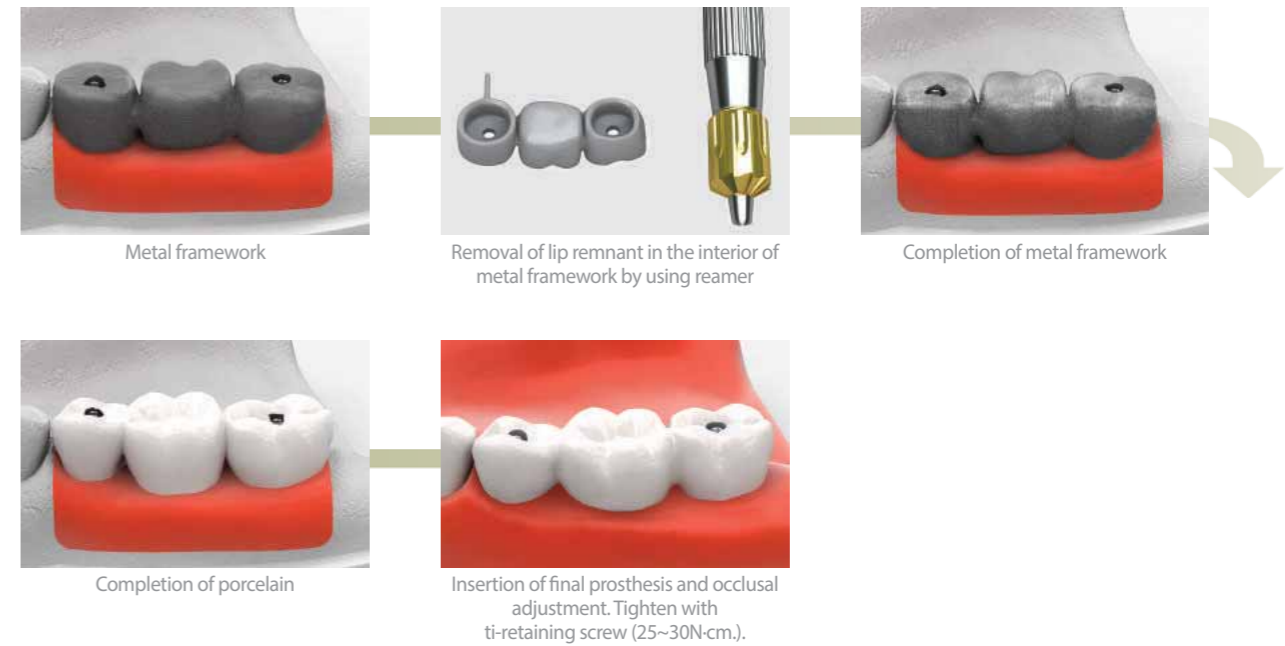

# Cementation Repair Method (SCRP)

[Screw & Cement Retained Prosthesis]

## In Light of Implant Prosthesis:

- A screw type restoration helps to simplify prosthesis repair, including insertion and removal of the prosthesis if necessary.
- Cement type restoration tend to have a stable occlusion and may enhance the adaptability. However the weak point is that it cannot be removed after permanent cementation.
- A Dual Abutment can be cemented or screw retained.
- Combi Abutments are cement retained and no occlusal hole is necessary.

## In Case of Screw Loosening or when Prosthesis Repair is Needed

In case of the following: screw loosening Prosthesis repair

In order to unscrew, form access hole on the occlusal surface using bur.

Unscrew, then remove the prosthesis from the oral cavity.

Both cemented prosthesis and abutment are removed.

Finish the repair then seat it inside the oral cavity.

Tighten the prosthesis with 25~30N-cm by a screw driver.

\* It is recommended that the abutment screw is retightened after 15 minutes.

Fill the access hole with cotton.

Fill the access hole with resin.

Final prosthesis

# Cementation Repair Method (SCRP)

[Screw & Cement Retained Prosthesis]

## Prosthesis Separation from Abutment due to Cement Loss

Remove the screw completely with screw driver and remove prosthesis from the patient's mouth.

Apply cement to the prosthesis.

Place it back into the patient's mouth.

After the cement setting, unscrew and remove the excessive cement.

Finish the repair and seat it inside the patient's mouth.

Tighten the prosthesis with 25~30N-cm with a screw driver.

## Adding to the Interproximal Contact Surface due to Prosthesis Loosening

Prosthesis loosening due to contact loosening

Form access hole using bur

Unscrew, then remove the cemented prosthesis with abutment in the oral cavity.

Contact adding with resin on the prepared under space.

Insert the prosthesis in the oral cavity and screw it in. Afterwards, perform light curing, then polish the contact area.

\* It is recommended that the abutment screw is retightened after 15 minutes.











Position the prosthesis in the mouth and tighten the screw with 25~30N-cm, then fill up the access hole.

# Prosthetic Procedure 4

Impression Technique and Restoration Type

## Overdenture Procedure

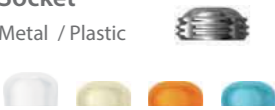
### Positioner / Mini Ball / Magnetic Attachment

<p><b>Positioner Abutment</b> Ø 3.5</p> 	<p><b>Mini Ball Abutment</b> Ø 3.5</p> 	<p><b>Magnetic Implant Keeper</b> Dome type / Flat type Ø 4.5 / Ø 5.5</p> 
<p><b>Abutment Level Impression</b></p>		
<p><b>Positioner Impression Coping</b> Ø 4.5</p> 	<p><b>Mini Ball Impression Coping</b> Ø 3.5</p> 	
<p><b>Positioner Analog</b> Ø 3.5</p> 	<p><b>Mini Ball Analog</b> Ø 3.5</p> 	
<p><b>Block Out Spacer</b> Ø 6.5</p> 	<p><b>Socket Spacer</b> Ø 4.05 / Ø 4.85</p> 	
<p><b>Positioner Socket</b> Metal / Plastic</p> 	<p><b>Mini Ball Female Socket / O-ring</b> Ø 4.05 / Ø 4.85</p> 	<p><b>Magnetic Assay</b> Dome type / Flat type Ø 4.5 / Ø 5.5</p> 
<p><b>Positioner Attachment for Overdenture</b></p>	<p><b>Mini Ball and Socket Attachment for Overdenture</b></p>	<p><b>Magnetic Attachment for Overdenture</b></p>

# Positioner

## Chairside



Connect the Positioner Abutment onto the fixture.

Affix the impression coping on the Positioner Abutment.

Take Impression for the production of individual tray.

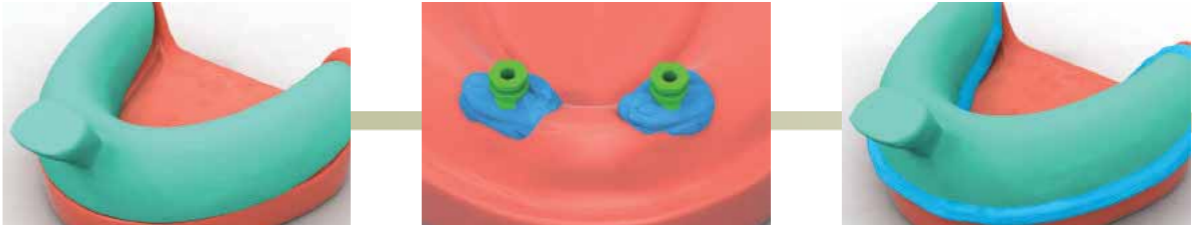

Produce the individual tray for denture impression.

After connecting the Positioner Abutment and the impression coping together, apply the impression material.

Take the final impression with the prepared individual tray.

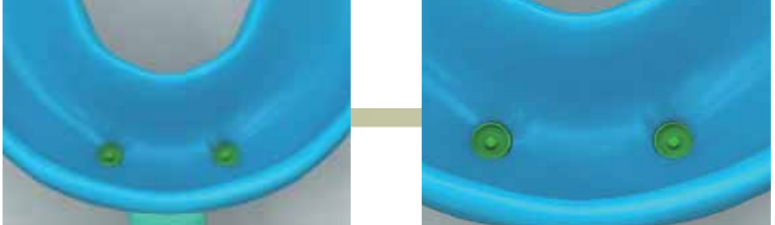

After the impression material is set, discard the individual tray.

Image of the set final impression (with impression coping)

## Labside



Positioner Analog

Insert the Positioner Analog into the embedded impression coping.

Create the master model.

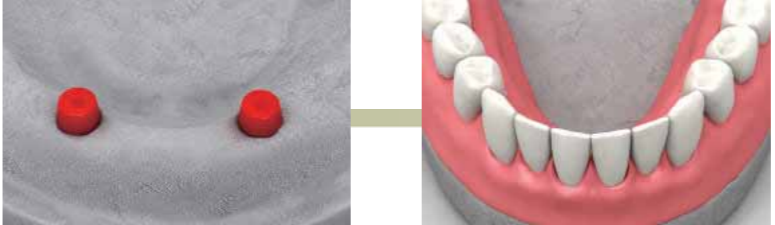

"Block out" procedure to achieve the space required for the metal socket.

Fabrication of denture with conventional method

# Positioner

## Case 1

### Chairside



Secure spaces for the female sockets.



Place the "block out spacer" on the Positioner Abutment in the patient's mouth.



Connect the metal socket onto the Positioner Abutment.



Apply a small amount of resin into the space created for the metal socket.



Position the denture in the mouth and wait until the resin is completely set.



Remove the white plastic socket (100gf) using the positioner tool and assemble with the regular plastic socket giving the desired retention force (300, 500 or 1000gf).



Secure spaces for the female sockets.



Place the "block out spacer" on the Positioner Abutment in the patient's mouth.



Connect the metal socket onto the Positioner Abutment.

# Positioner

## Case 1

### Chairside



Create holes for the placement of the metal sockets.



Place the "block out spacer" on the Positioner Abutment in the intraoral.



Connect the metal socket onto the Positioner Abutment.



Examine the interference between inner surface of the holes and the female sockets.



Apply the resin into the holes and wait until it is completely set.



Remove the white plastic socket (100gf) using the Positioner tool and assemble with the regular plastic socket giving the desired retention force (300, 500 or 1000gf).



Apply additional resin around the metal socket where there is a shortage of resin.



Apply resin around the metal socket.



After polishing, the overdenture is completed.

# Mini Ball Attachment

## Case 1



Secure spaces for the female sockets.

## Chairside



Connect the female sockets to the Mini Ball Abutments in the intra-oral.



Apply small amount of the resin into the secured area.



Position the denture in the oral cavity and wait until the resin is completely set.



Female sockets are placed in the denture.



After polishing, the overdenture is completed.

## Case 2



Create holes for placement of female sockets.



Connect the female sockets to the Mini Ball Abutments in the intra-oral.



Examine the interference between inner surface of the holes and the female sockets.



Apply the resin into the holes and wait until it is completely set.



Female sockets are placed in the denture.



Apply resin around the female sockets.



After polishing, the overdenture is completed.

# Magnetic Attachment

## Chairside

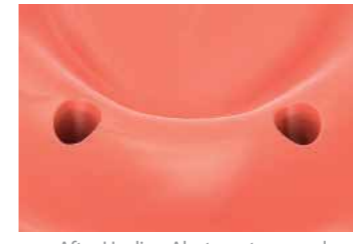

After Healing Abutment removal

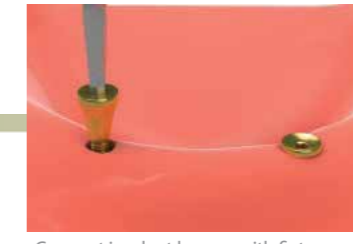

Connect implant keeper with fixture and tighten it with 25~30N-cm.

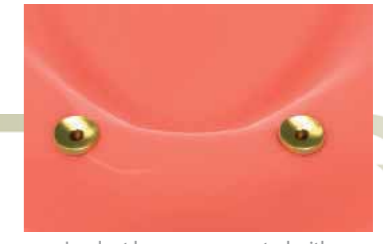

Implant keepers connected with the fixtures



Position the magnetic assay on the implant keeper.



Secure spaces for the magnetic assays.



Examine the interference between inner divot of the denture and the magnets.

## Case 1



Apply resin on the divot of the denture's inner surface.



Position the denture into the mouth and wait until the resin is completely set.



Magnetic assays are placed in the denture.



Apply some of resin around the magnetic assays.



After the resin is completely set, remove excess. After polishing, the overdenture is completed.

# Magnetic Attachment

## Case 2



Create holes for the placement of the magnets.

## Chairside



Examine the interference between inner surface of the holes and the magnets.



Position the denture in the mouth and apply small amount of resin into the hole.



Wait until the resin is completely set.



After setting, remove denture from the mouth.



Add the resin around the magnets.



After polishing, the overdenture is completed.

## Renewal



## New Product

