



TESS660

SIDELOCK TENSION SYSTEM

Guthrie Douglas

Distributed by

horiso[®]

horiso.com.au

TESS660

Designed to eliminate light gaps.

The only tensioned zip screen that will not let you down. The TESS 660 is engineered to deliver total reliability, discretely. Our SideLock mechanism stops the fabric blowing out of its guides. Our single barrel drive mechanism keeps the fabric constantly under tension and produces a smooth, ultra-quiet travel with no risk of hem bar jamming. Blackout capability for the right environment at any time of day. Suitable for internal or external use, with unlimited colour finishes and a wide range of fabrics making it suitable for any project.

- **CE marked wind class 3**
- **Any angle, any direction**
- **Blackout capability**
- **SideLock fabric retention**
- **Ultra-quiet motor**



TESS660

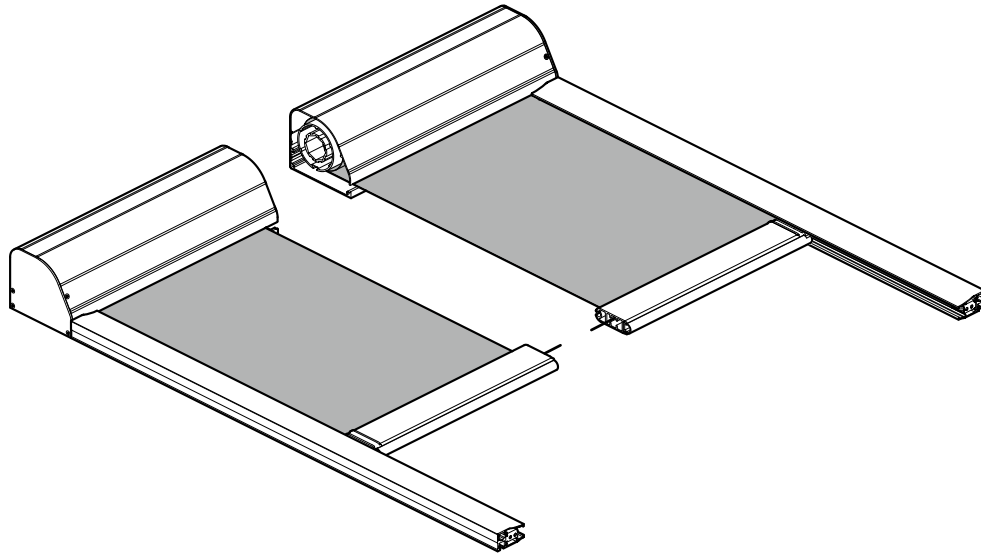

660/660L

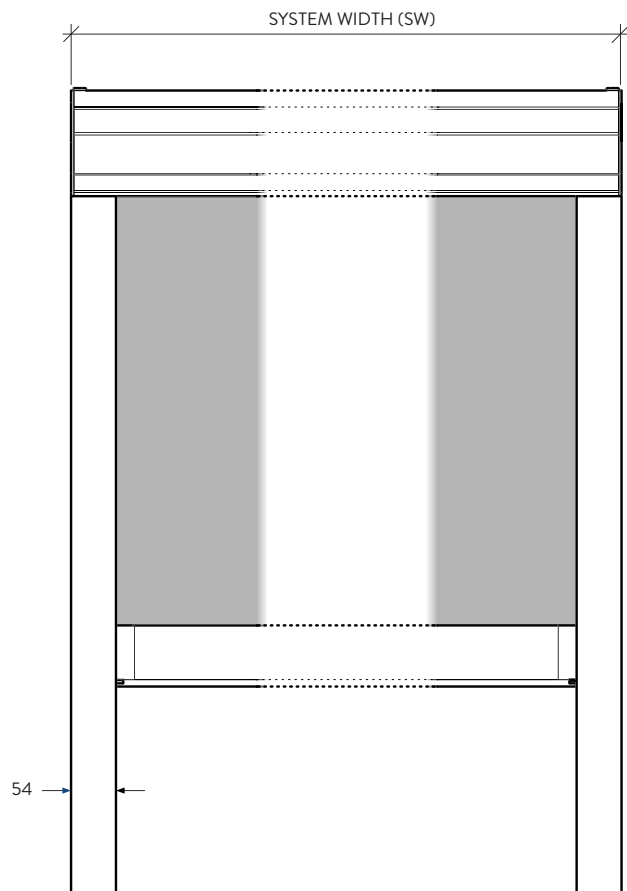
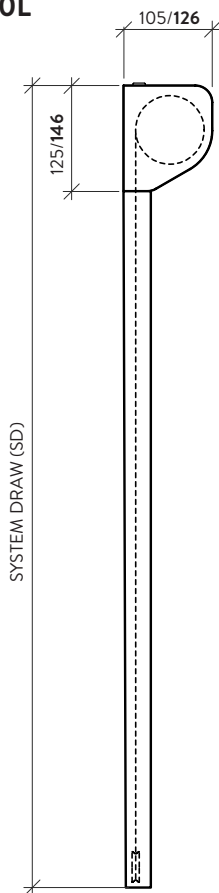

TESS660

Key Facts

Typical use	Skylights, blackout
Shape	Rectangular
Running direction	Any
Guides	Aluminium profile
Width	650 mm - 3000 mm
Draw	≤3000 mm / ≤4500 mm
Fabric area	≤9 m ² / ≤13 m ²
Brackets	Aluminium
Finish	RAL Powder coat
Installation options	Face, reveal

Technical Information

Fabric tension	>100 N
Weight exc. Fabric	~8 kg + 4 kg/m width + 1.6 kg/m draw
Fixing load	≤5 kg per fixing point
Operating temp.	0 to 55 °C
Motor	9 Nm, 12 rpm
Electrical	230 V, 50 Hz, 120 W, 0.55A 120 V, 60 Hz, 130 W, 0.98A
Max run time	4 min
Fabric speed	~3 m/min
Controls	Radio, Wired



horiso®

E: info@horiso.com.au | T: +612 8755 4500

horiso.com.au