



Tension Shading System 421 Shaped External wire guided tension system



Applications

STS 421 is designed for use on both commercial and residential buildings.

The STS 421 is a unique design for right-angled triangular fabric shades over horizontal and sloping glazing.

Design Specifications

- A single 85 mm galvanized steel fabric roller tube incorporating both the motor and spring tension compensation cassette to maintain constant tension throughout the travel.
- Extruded aluminium head box.
- A gear-operated mechanical tension adjustment within the drum to enable the fabric tension to be adjusted between 5 and 25 kg.

Design Options

- Relieving roller for intermediate fabric support (recommended for draw over 3 m).
- Boat shaped hem bar end caps to allow smooth passage over relieving rollers.
- Fabric battens to minimise fabric sag.

Finishes

- Visible aluminium parts Syntha Pulvin® polyester powder-coated in the system colour specified.

Installation Options

- System available with relieving roller.

Maximum width: 4 m

Maximum draw: 5 m

Maximum fabric area: 9 m²

Maximum fabric weight: 450 g/m²

STS 421 Components

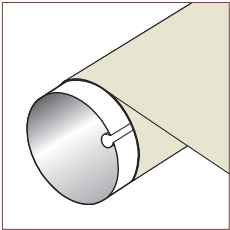

1 Fabric roller

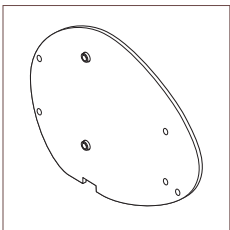

2 Cheek plate

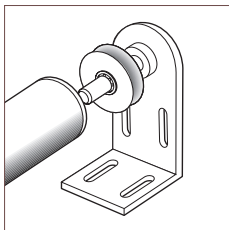

3 Relieving roller bracket

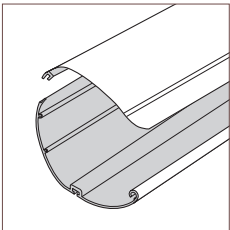
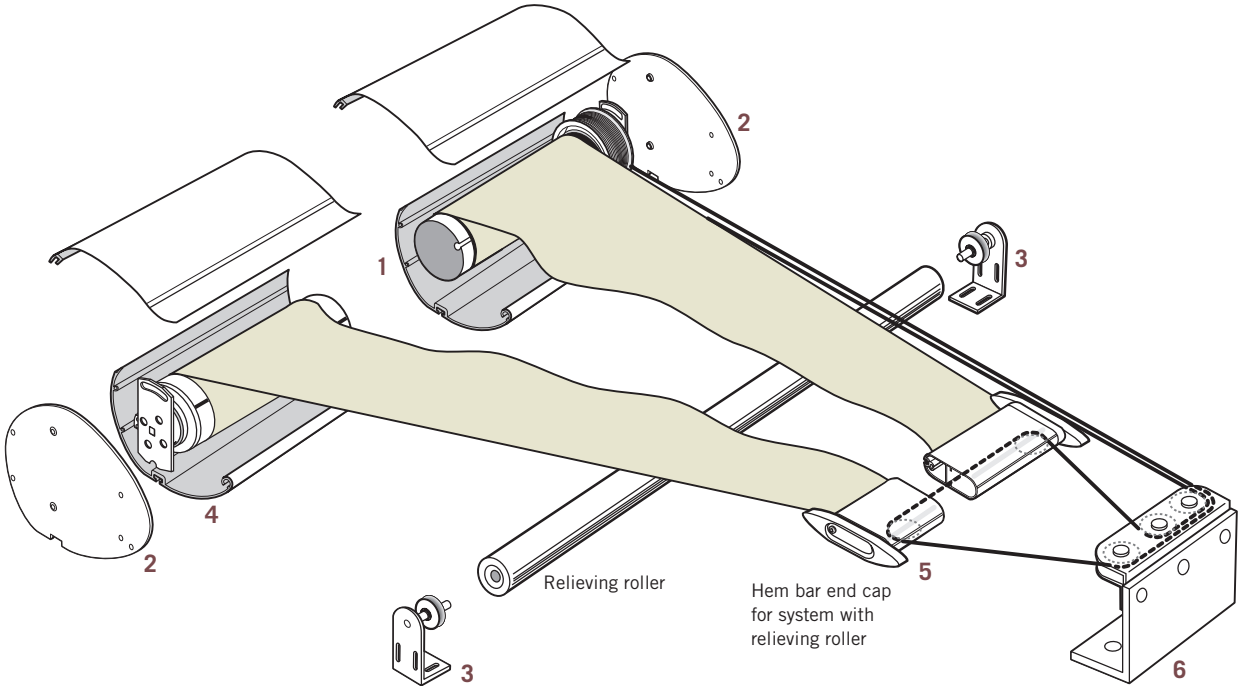

4 Section through hood

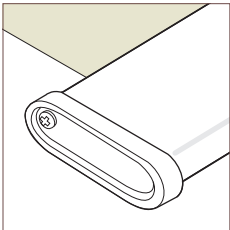

5 Hem bar end cap for system without relieving roller

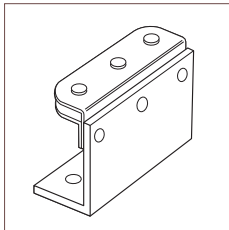

6 Return pulley assembly

STS 421 Technical specifications

Model		T11460
Maximum width	(m)	4
Maximum draw	(m)	5
Maximum fabric area	(m ²)	9
Basic weight		
1 metre wide system (max)	(kg)	15
Additional weight per metre width (max)		
	(kg)	5
Typical fixing load	(kg)	24
Fixing load (max)	(kg)	36
Motor		
Torque	(Nm)	15
Speed	(min ⁻¹)	17
Current at 230 V	(A)	0.6
Cable length	(m)	2.5
Temperature range	(°C)	-5 to +55
Maximum run time	(min)	4
Minimum fabric speed	(m/min)	5

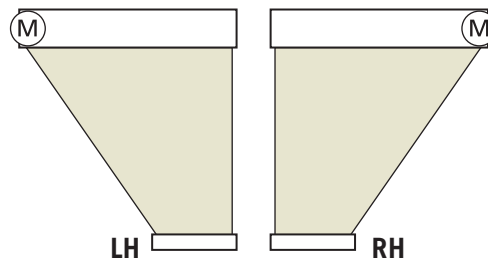
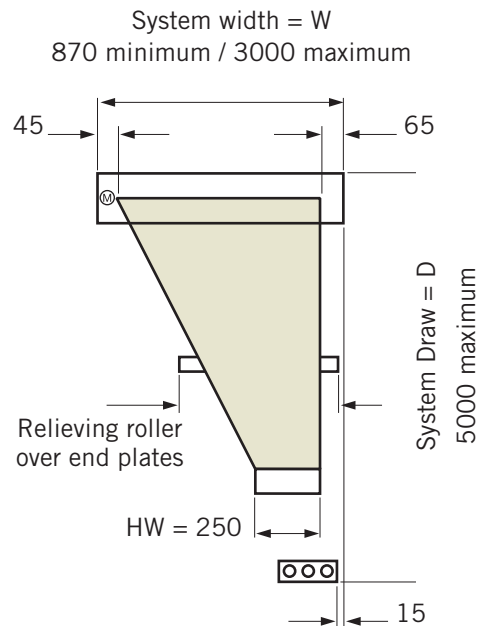

Supplied with left or right motor

