

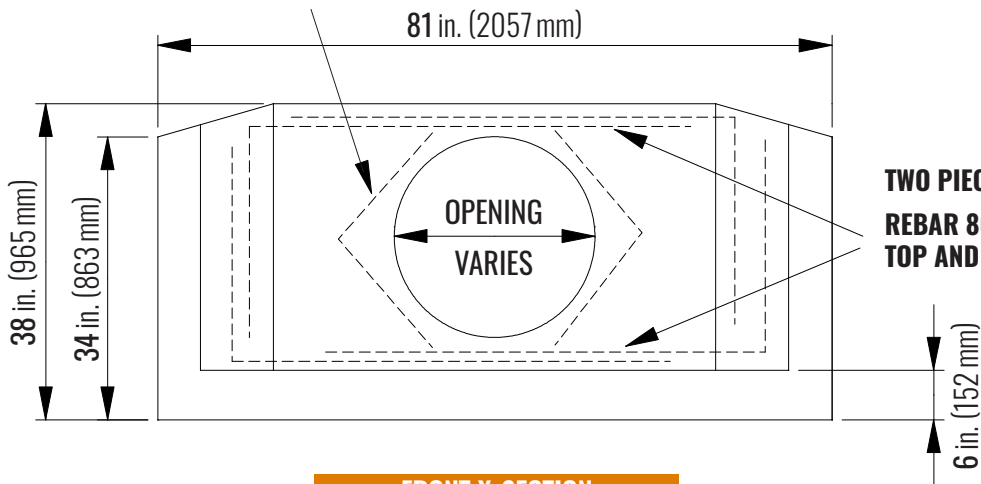

Casey Concrete Ltd. PRECAST CONCRETE CULVERT END

caseyltd.ca

**80 in. LENGTH OF 10 m REBAR
BENT EITHER SIDE OF OPENING**



FRONT X-SECTION

**TWO PIECES OF 10 m REBAR
REBAR 80 in. LONG
TOP AND BOTTOM**

THERE ARE 3 OPENING SIZES AVAILABLE

- 21 in. (533 mm) – [18 in. pipe]
- 28 in. (711 mm) – [24 in. pipe]
- 15 in. (381 mm) – [12 in. pipe]

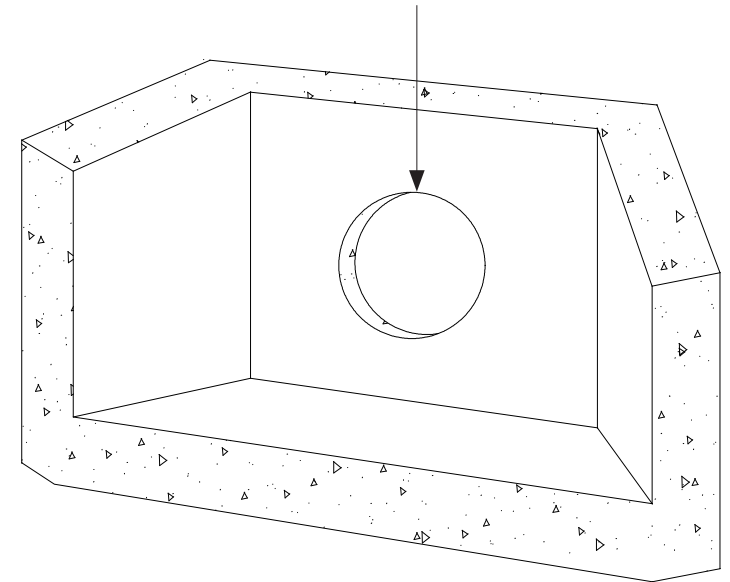

PERSPECTIVE

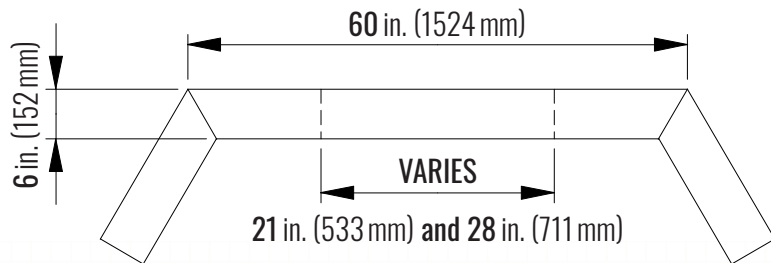
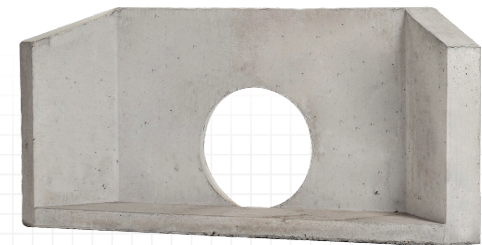

TOP VIEW

PACKAGING:

Pieces Per Pallet: 1
Weight Per Piece: 909 kg (2000 lbs) +/-

PHYSICAL PROPERTIES:

Meets the requirements of CSA A23.1
Compressive Strength: Min 30 MPa @ 28 Days
Concrete Contains: 5-8% Entrained Air

PLEASE NOTE:

Products are made from natural material sources and therefore colour variations are common. Efflorescence is also a common occurrence with all concrete and concrete products. Efflorescence does not affect the quality of the product and will fade over time or can be removed with cleaning products.