

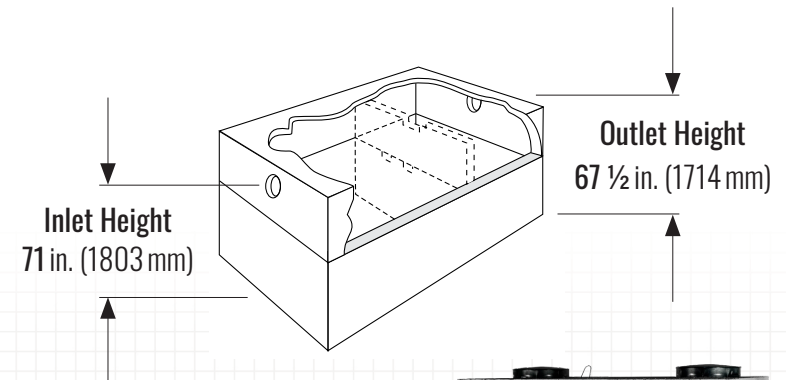

# Casey Concrete Ltd. PRECAST 4646 L (1022 GAL) SEPTIC TANK

caseyltd.ca

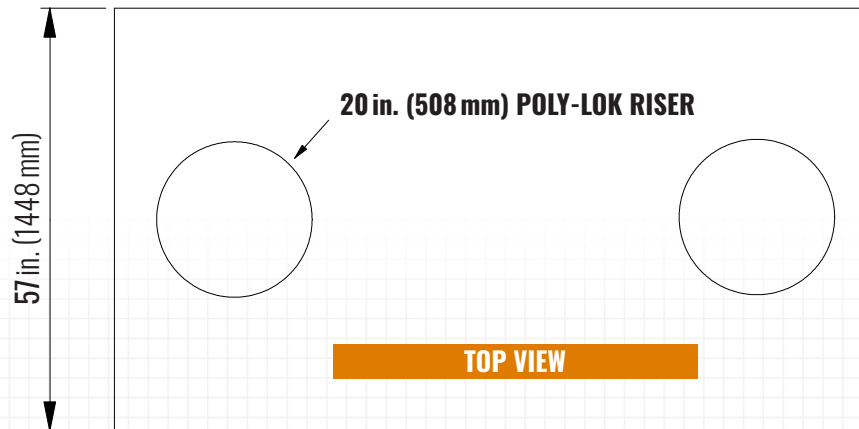
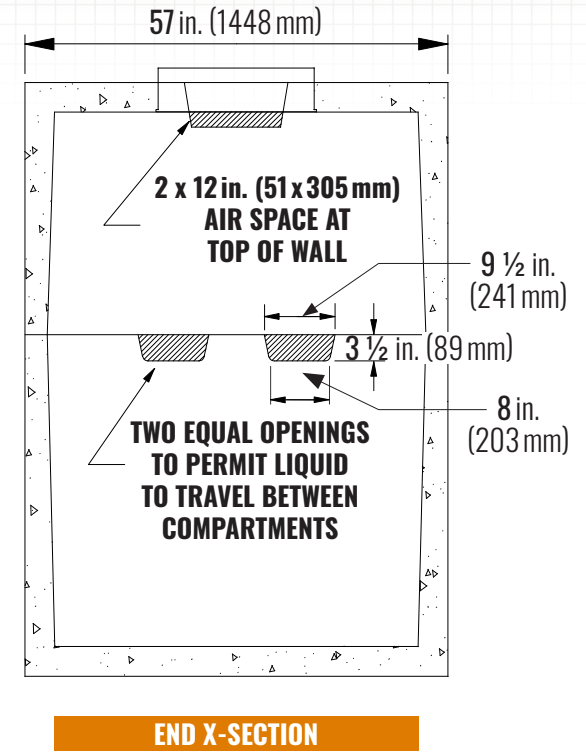
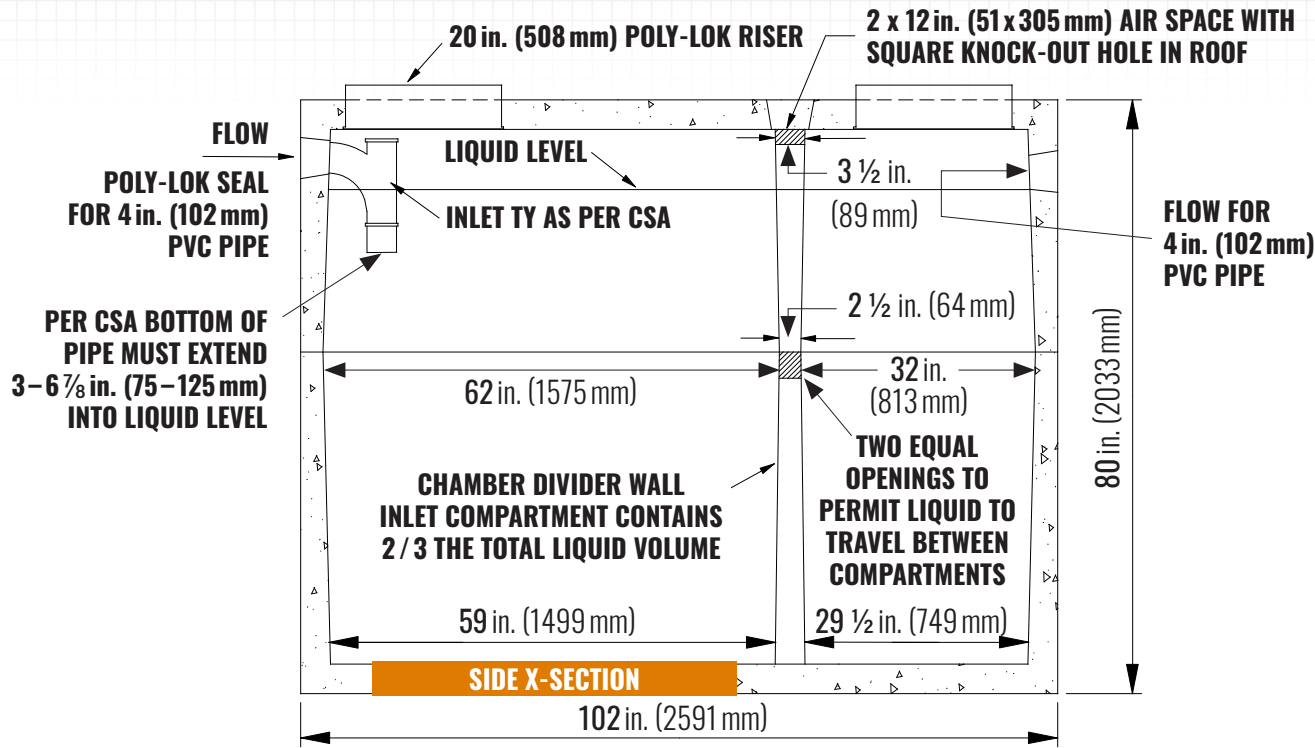

## PACKAGING:

Top Section Weight: 2430 kg (5350 lbs)+/-  
 Bottom Section Weight: 2910 kg (6400 lbs)+/-  
 Total Assembled Weight: 5340 kg (11750 lbs)+/-

## PHYSICAL PROPERTIES:

Concrete meets requirements of CSA A23.1  
 Compressive Strength: Min 32 MPa @ 28 Days  
 Concrete Contains: 5-8% Entrained Air