

TOP VIEW

FOR REFERENCE ONLY
DO NOT USE FOR CONSTRUCTION

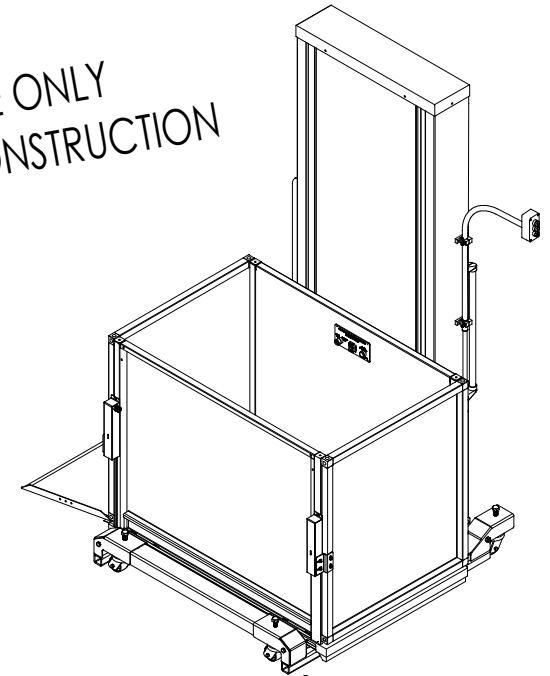

VUE ISOMÉTRIQUE

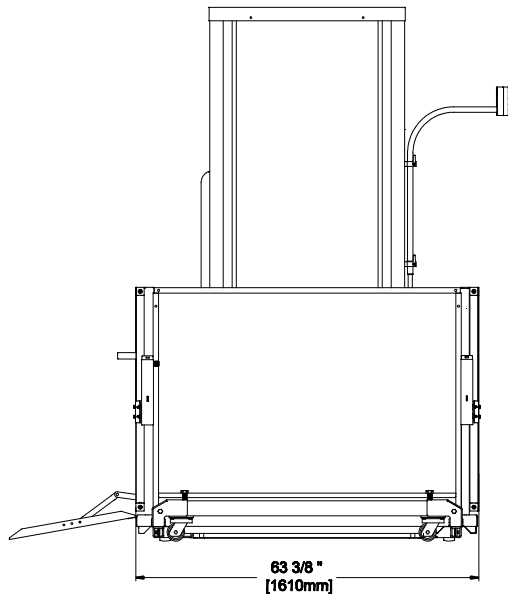
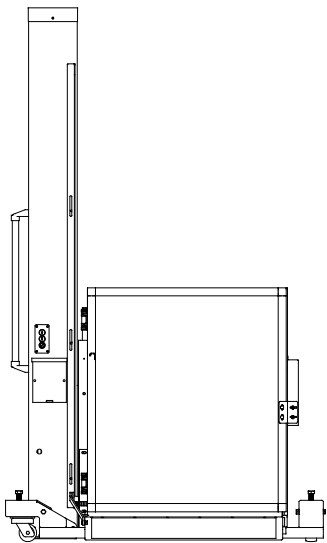

ELEVATION

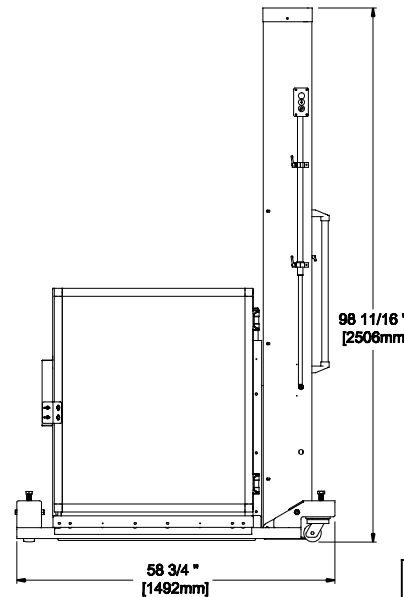

DRAWING FOR APPROBATION			
CHOOSÉ (✓)	APPROVED		
	APPROVED AS NOTED		
	RESUBMIT AS NOTED		
SIGNATURE		DATE	
SIGN AND RETURNED TO ATLAS			

PROJET: **TYPICAL DRAWING**

CONFIGURATION DETAILS			
XX	XX	XX	XX-XX-2018
REV	BY	DESCRIPTION:	DATE:

DOOR INTERLOCK TYPE: HONEYWELL

Guard panel:
81" HEIGHT

Safety:
± 1/16"

Draftsman:
M. Debusschere

Date:
10/12/2018

Les Escalateurs Atlas Inc.
3175 Boul. Choquette
St-Hyacinthe (Québec)
J2S 7Z8, Canada
Tél: (450) 796-5708
Fax: (450) 250-5110

- SPECIFICATIONS**
- Capacity: 750lbs
 - Travel: 8" à 48" (variable)
 - Motor: 1hp, 24 volts DC
 - Battery operated
 - Power requirement of the chargers: 120volts AC, 15A
- *Spécifications subject to changed without notice

1 Vista Mobile

*However the stage lifts for disabled peoples are not included in the scope the hereby mentioned codes; the components and the design of the device comply with the state of the art found in CSA B355-09, ASME A18.1 and ASME A17.1/CSA B44.

No Drawing: **VISTA MOBILE_34x60**

Status: **INFORMATION**

Revision: **1/1**

No Sheet: **1/1**