

# Vista Mobile

Outdoor or Indoor wheelchair lift



Products  
made in 

[www.atlasaces.com](http://www.atlasaces.com)



## Description : Outdoor or Indoor wheelchair lift

### Reaches standard

CSA/B355-09

### Device category

- Wheelchair lift Vista Mobile, indoor and outdoor use.
- Vertical lift, open shaft.

### Vehicule type

- Vertical platform for one person in a wheelchair and one helper
- Standard floor dimensions : 864mm x 1524mm (34 in x 60 in)

### Available cabin size

Dimensions: Width: 800 mm to 1 018 mm (31,5 in to 40 in)  
Lenght: 1 219 mm to 1 619 mm (48 in to 66 in)

### Included:

- 2 x 34'' wide gate galvanized steel
- 2 x call station
- 24 volts, Dc power
- Under floor safety pan
- 2 x door closer

### Installation requirements

A firm and level ground surface ex: concrete slab, wood, tiles...  
GFCI outlet close to the lifting tower

## Technical specifications

- Maximum capacity : one person in a wheelchair and one helper
- Maximum load : 340 kg (750 lbs)
- Drive type : Acme screw and nut
- Motor : DC, 24 volts
- Nominal speed : 0,05 m/s (9 fpm)
- Available travel distance : 44'' (1117mm) or 64'' (1625 mm)

**Controller** : CSA Certification LR45147

**Door interlock** : CSA Certification LR13004

## Special features

Fast travel time

Controller and panel : industrial grade components from Télémécanique

Weatherproof control buttons

Flexible paint finish resists shocks

Anti-skid floor surface

**SHORT DELIVERY TIME**

**FAST INSTALLATION**

**EASY TO MOVE**

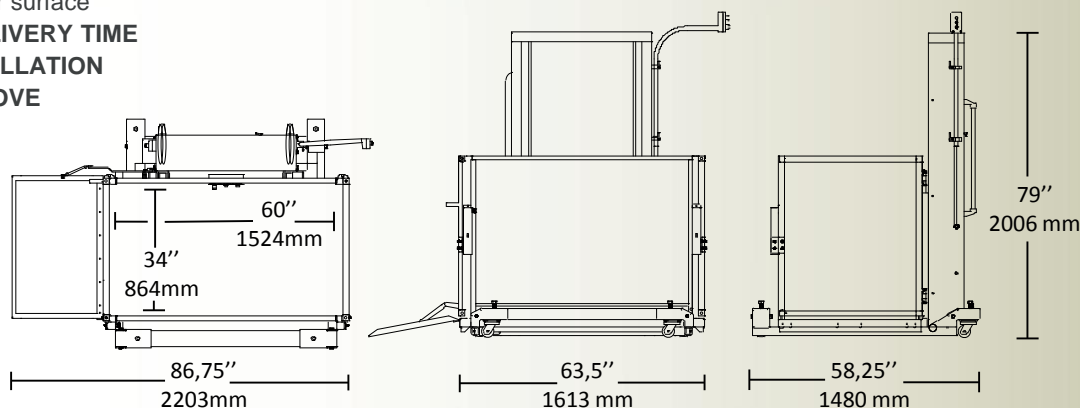

Notes :



**Les Escalateurs Atlas inc.**

Saint-Hyacinthe J2R 1E8

Phone : 1888 773-6708

Fax : 450 796-5110

Email : info@atlasacces.com

www.atlasacces.com