

1. PROVIDE ONE GFI 120VAC 15A OUTLET CLOSE TO THE BACK OF TOWER ONLY IF A MIN 24" ACCESS WAY IS AVAILABLE, OTHERWISE COORDINATE WITH LIFT INSTALLER
2. PROVIDE ALSO ONE WIRE AT THE SAME PLACE 120VAC, 15A. BY ELECTRICIEN

NOTE  
DIRECTION OF DOOR OPENING MAY BE CHANGED

RUNWAY MUST BE SMOOTH AND EXTEND 12" MIN. ON EACH SIDE OF LANDING GATE. OTHERWISE, EXTEND ON ALL AVAILABLE AREA. (SEE DETAIL "A"). BY GENERAL CONTRACTOR

**1 VISTA-355-AB 36x60 (WITHOUT HELPER)**

NOTE  
1. PROVIDE 100 lx MIN. LIGHTING TO THE WHOLE PLATFORM (BY ELECTRICIAN).  
2. ANY WALL LOCATED LESS THAN 12" (WITHOUT HELPER) OR 24" (WITH HELPER) AWAY FROM THE CAB MUST EXCEED THE UPPER LANDING HEIGHT BY AT LEAST 42". IT MUST BE SMOOTH (NO RECESSES OR PROTRUSIONS).

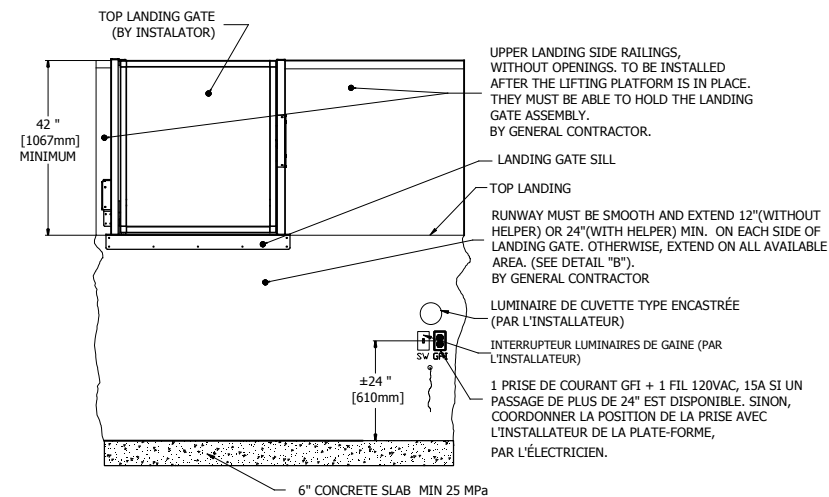

**2 DETAIL B**

NOTE  
LIFT NOT SHOWN FOR CLARITY PURPOSE OF THE DRAWING.

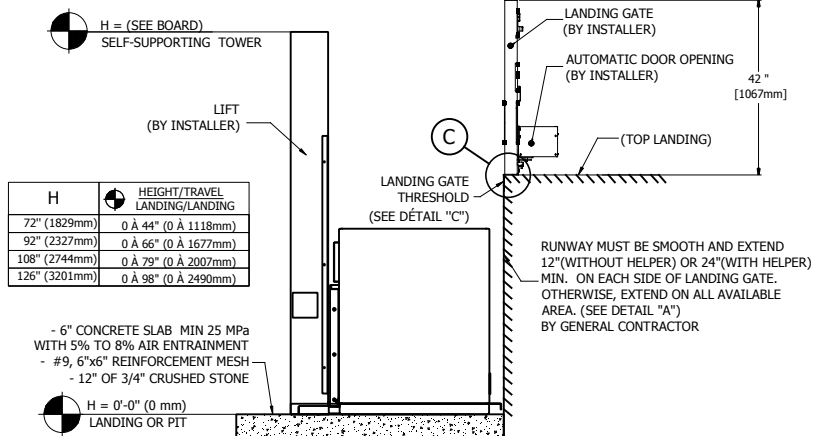

**3 DETAIL A FLOOR ELEVATION**

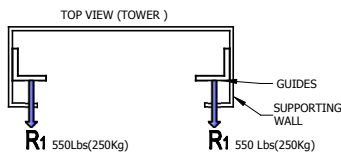

**5 RAIL REACTIONS**

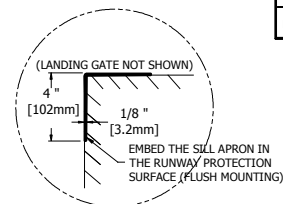

**4 DETAIL C**

VISTA_355 TECHNICAL DATA	
TYPE	Outdoor use, vertical lift, open shaft
CODE	CSA/B355-09
MAX CAPACITY	One person a wheelchair or One person a wheelchair and one helper
MAX LOAD	750 lb (340 Kg)
RAIL LINEAR WEIGHT	5 lb/ft
TRACTION MACHINE	Acme screw and nut
ALIMENTATION	DC, 24 VOLT
VELOCITY	9 ft/min (0.05 m/s) *option max speed: 14 ft/min (0.07 m/s)
MAX TRAVEL	98 in (2500 mm) max.
EMERGENCY BRAKES	Bronze safety nut
CAB FINISH	See document C-02
LIFT CAB	Max floor dimensions 40 x 66 in (1018 mm x 1679 mm)
FLOOR FINISH	Anti-skid floor surface
CONTROL BUTTONS	Weatherproof control buttons
CONTOLER	BECVISZ3 (CSA/LR45147)
DOOR INTERLOCK	HONEYWELL (REALIGN) or GAL (TYPE N)

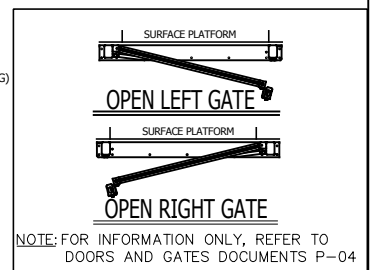

**6 VISTA 1000 Lb REACTIONS**

**5 VISTA 750 Lb REACTIONS**

NOTE  
-THIS ELECTRONIC DOCUMENT IS NOT SIGNED OR SEALED BY AN ENGINEER AND MAY NOT BE USED FOR CONSTRUCTION PURPOSES.  
-THIS ELECTRONIC DOCUMENT IS STRICTLY FOR INFORMATION PURPOSES (OR COORDINATION, AS APPLICABLE).  
-NO GUARANTEES ARE GIVEN ON THE INTEGRITY OF THE TRANSMITTED INFORMATION.  
-NO GUARANTEES ARE GIVEN ABOUT PAST OR FUTURE CHANGES TO THIS DOCUMENT

**Les Escalateurs Atlas Inc.**  
8255 Boul. Laframboise  
St-Hyacinthe (Québec)  
J2R 1E8, Canada  
Tél: (450) 796-5708  
Fax: (450) 796-5110

GÉNÉRAUX INFORMATIONS		
TITLE		
No. DRAWING	VISTA_AB	DATE: 26/01/2016
CODE:	B355	DRAFTER: M. Debusschere
		REVISION
		No SHEET: 1/1