

# RIGHT HAND TYPICAL INSTALLATION

STAIR ANGLE	24	25	26	27	28	29	30	31	32	33	34	35	36	37	38	39	40	41	42	43	44	45	46	47	48	49	50	51	52	
L1	143	139	136	134	131	129	136	134	122	120	118	117	115	113	112	110	109	108	106	105	104	103	99	96	92	89	85	82	79	
L2 FOOTREST HEIGHT AT UPPER LANDING	0	-29	-16	-4	8	19	29	39	48	56	64	73	80	89	95	102	109	115	122	128	134	140	146	152	157	161	167	172	178	183
	50	95	103	111	111	125	132	139	145	152	157	163	167	174	178	183	188	193	198	202	207	212	216	221	225	229	233	237	242	246
	100	219	222	226	226	232	235	239	242	245	249	253	255	259	262	264	268	271	273	276	281	284	286	290	293	296	300	302	307	309
	150	341	340	338	338	338	338	339	339	340	341	341	342	344	345	346	347	350	350	352	354	356	357	359	362	364	366	368	371	373
	170	390	387	385	385	381	379	379	378	378	377	377	377	378	378	379	380	380	382	383	385	385	387	389	390	392	394	397	398	
B	390	392	394	396	399	401	404	407	411	414	417	420	424	427	431	434	438	441	445	449	453	456	458	460	463	465	467	470	473	
C	101	101	101	101	100	100	99	99	98	97	96	95	94	93	92	91	89	88	86	85	83	83	82	81	81	81	81	80	80	
D	-67	-57	-48	-40	-32	-25	-19	-13	-8	-4	0	4	9	11	14	17	19	21	22	24	25	27	29	31	33	35	37	39	40	
D+	160	159	159	157	156	155	154	153	152	151	150	148	146	144	142	140	138	135	133	131	129	126	125	124	123	122	121	120	118	
E	143	134	127	119	113	107	102	97	93	89	85	82	79	77	74	72	70	68	67	66	64	63	62	62	62	61	61	61	60	
F	-83	-81	-78	-77	-75	-73	-71	-69	-67	-65	-63	-61	-59	-57	-54	-52	-49	-46	-42	-42	-39	-36	-34	-31	-28	-25	-23	-20	-17	

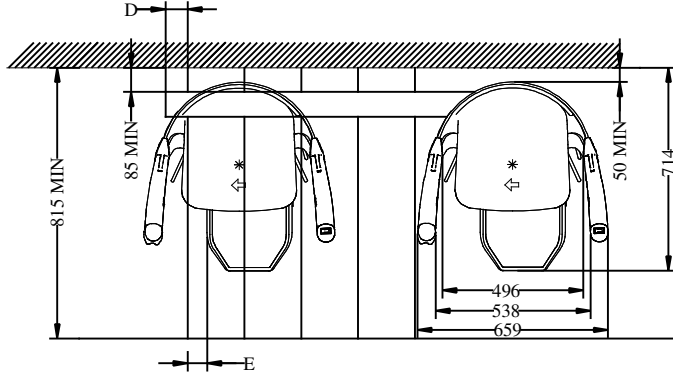

## REACTIONS DETAIL

R1	725 N
R2	985 N
R3	1141 N
R4	295 N
R5	912 N

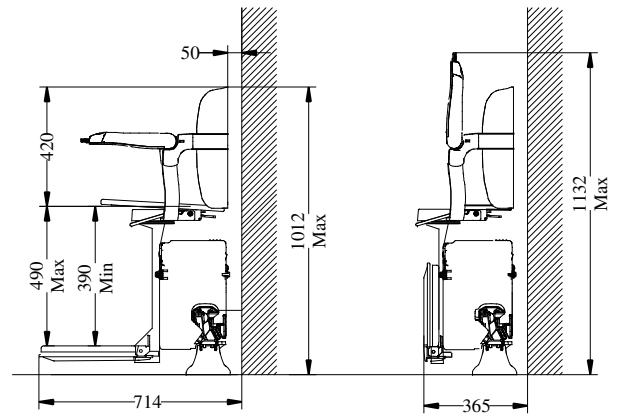
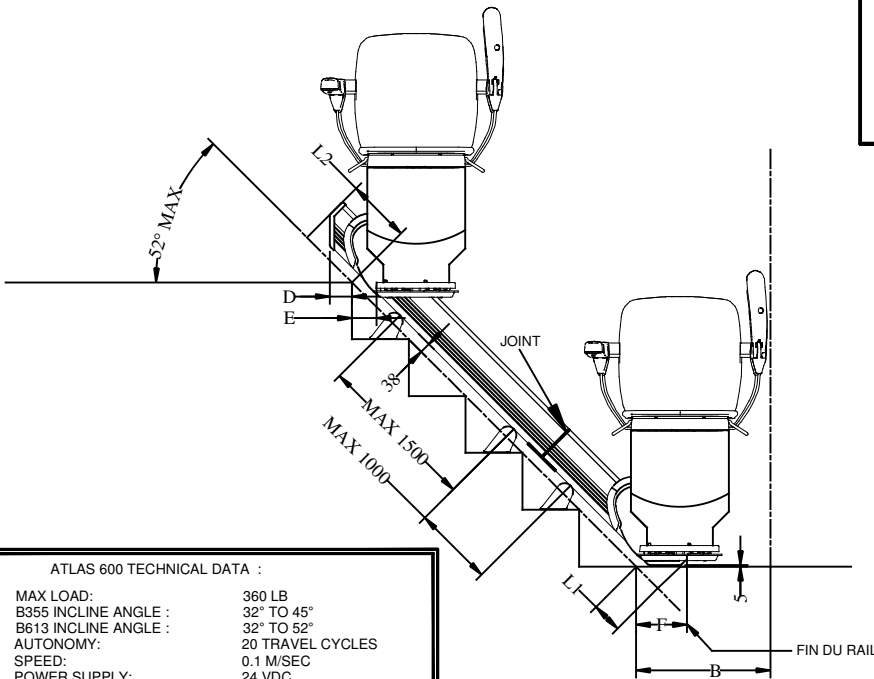
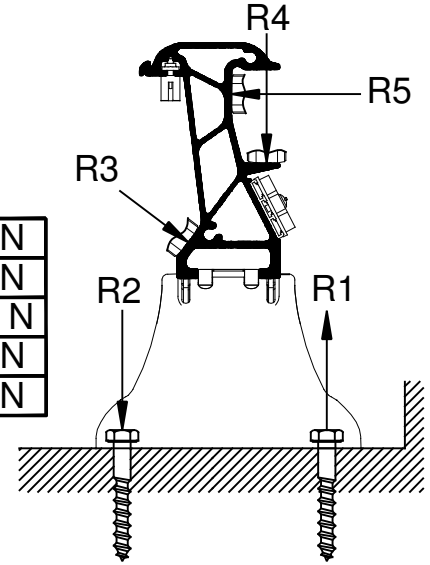

### ATLAS 600 TECHNICAL DATA :

MAX LOAD:	360 LB
B355 INCLINE ANGLE :	32° TO 45°
B613 INCLINE ANGLE :	32° TO 52°
AUTONOMY:	20 TRAVEL CYCLES
SPEED:	0.1 M/SEC
POWER SUPPLY:	24 VDC
MAX TRAVEL:	30 000 MM
MOTOR:	24 VDC
CHARGER INPUT POWER :	120 VAC 50-60 HZ
DRIVE TYPE:	RACK-AND-PINION
RAIL:	EXTRUDED ALUMINUM
COVERS:	ABS UL E56070

### NOTE

- THIS INSTALLATION PLAN COVER THE STAIRLIFT INSTALLATION OF IN THE STAIRCASE.
- INSTALL A MINIMUM OF THREE ANCHORING SUPPORTS, EQUIDISTANT AS MUCH AS POSSIBLE.
- MAXIMUM DISTANCE OF 1000MM BETWEEN TWO ANCHORING SUPPORTS FOR A JOINTED RAIL SECTION.
- MAXIMUM DISTANCE OF 1500MM BETWEEN TWO ANCHORING SUPPORTS FOR A NON-JOINTED RAIL SECTION.
- THE ANCHORING SUPPORTS MUST NOT OVERLAP THE TREAD NOSE TO AVOID CREATING A PINCH OR SHEAR POINT.
- MAKE SURE TO PROVIDE A 50 LX MINIMUM LIGHTING FOR EACH LANDING AND FOR THE STAIRLIFT.
- SECURE EACH RAIL ANCHORING SUPPORT WITH 4 SCREWS (PROVIDED):
  - FOR WOODEN STEPS, USE #1/4"x2 WOOD SCREWS (1 3/4" MIN DEPTH).
  - FOR CONCRETE STEPS, USE #1/4"x1 3/4" ANCHORS (HILTI KWIK BOLT II).
  - ANY HARDWARE PROVIDING EQUIVALENT HOLDING CAPACITY MAY BE USED.
- TIGHTEN THE BOLTS ACCORDING TO THE TORQUE TABLE VALUES WITH A TORQUE WRENCH.
- BUILDING OWNER IS RESPONSIBLE TO OBTAIN ALL PERMITS AND REQUIRED AUTHORISATIONS FOR THE STAIRLIFT INSTALLATION IN REGARDS WITH BUILDING CODE, SAFETY CODE, FIRE DEPARTMENT, AND ALL OTHER AUTHORITIES HAVING JURISDICTION IN THE LOCALITY OF INSTALLATION.

TIGHTENING TORQUE	
NOMINAL DIAMETER	TORQUE LB*PI
M5	2
M6	3
M8	8
M10	17
M12	32

CODE: B355  
B613

**LES ESCALATEUR ATLAS**  
SAINT-HYACINTHE, QC.  
Tél: (450) 796-5708  
Télc: (450) 796-5110

TITLE: **ATLAS 600 TYPICAL INSTALLATION**

PREPARED BY	M. Debusschere	DATE	24/09/2015	No. DRAWING:	A600 INSTALL TYP	REV	
APPROVED	Julien Béliveau	DATE	30/09/2015	Scale:	1:1	SHEET	1/1