

1 AR-130-T_C

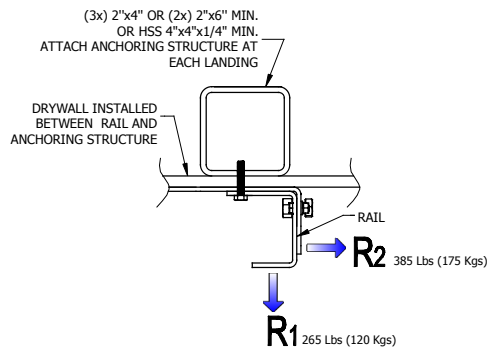

2 RAILS REACTION

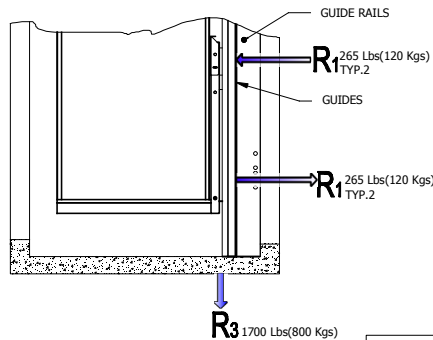

3 REACTION

NOTE:
HOISTWAY DESIGN MUST FOLLOW A SAFETY FACTOR OF 5, SEE CAN/CSA-B355.

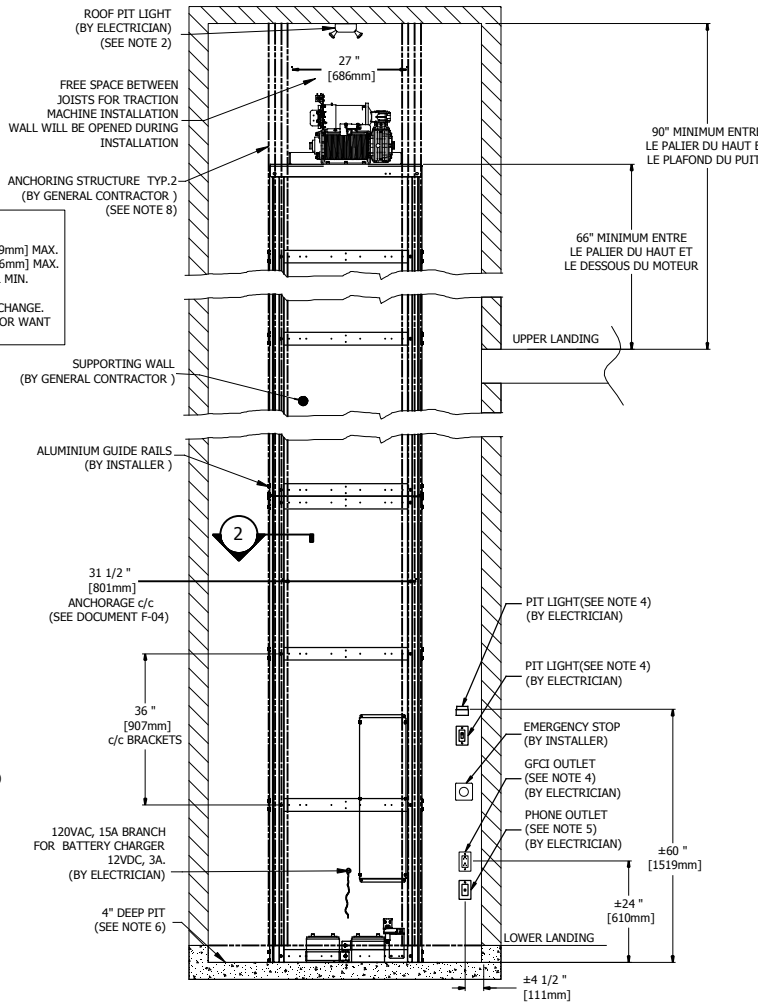

4 SUPPORTING WALL

DOOR INSTALLATION:
1) LEAVE A 3/4" SPACE ON EACH SIDE OF THE DOOR TO ALLOW SIDWAY ADJUSTEMENT ON SITE
2) THE LATCH SIDE JAMB OF THE LANDING DOOR MUST BE FLUSH WITH THE INNER FACE OF THE PLATFORM'S SIDE WALL.

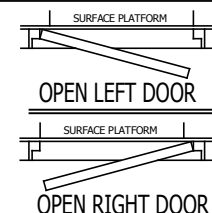

NOTE: FOR INFORMATION ONLY, REFER TO DOORS DOCUMENT P-01

- NOTE**
- ELEVATOR PLATFORM MODEL: **AR-130-T**
 - INSTALL 1 PERMANENT CEILING FIXTURE WITH MIN 2 BULBS (100 LUX MIN). A BULB FAILURE SHOULD NOT PREVENT THE OTHER BULB FROM LIGHTING.
 - INSTALL 1 FIXTURE AT EACH FLOOR, OUTSIDE THE HOISTWAY WITH THE SWITCH INSTALLED AS CLOSE AS POSSIBLE TO THE LANDING DOOR.
 - ROUTE TO THE SUPPORTING WALL, TWO 120VAC LEAD WIRES FROM THE BREAKER PANEL TO THE INDICATED LOCATION: ONE 24DC/120VAC 15A/1Ø/1N/1GND (1 BLACK+1 WHITE(NEUTRAL)+1 GND), ONE 15A FOR SHAFT LIGHTING, PIT LIGHTING, SWITCH LIGHT, GFCI TYPE OUTLET IN THE PIT. OUTLET BREAKER TRIP MUST NOT COMPROMISE LIGHTING.
 - TELEPHONE JACK PRIORITY FOR BILATERAL COMMUNICATIONS (HARD WIRE)
 - PREPARE A 4" MIN. PIT TO THE SAME INTERIOR DIMENSIONS AS THE ELEVATOR SHAFT. THE PIT SHOULD MINIMALLY BE MADE WITH 4" OF 25MPa REINFORCED CONCRETE WITH 5% TO 8% AIR ENTRAINMENT (6X6, #9 WIRE MESH).
 - SUPPORTING WALL MUST BE SMOOTH, WITHOUT RECESS OR PROJECTIONS ON ALL ITS SURFACE.
 - TRIPLE STUD HEIGHT SHOULD NOT EXCEED 12' UNLESS FIXED AT EACH 12'. STUDS CAN BE SUBSTITUTED WITH DOUBLE 2x6 STUDS, 4"x4"x 1/4" HSS SQUARE TUBING, APPROVED BY THE BUILDING'S STRUCTURAL ENGINEER.
 - ALL WORKS AND MATERIALS MUST CONFORM WITH AUTHORITIES HAVING JURISDICTION.
 - CHECK WITH ARCHITECT IF AUTOMATIC DOOR OPENERS ARE REQUIRED ON LOCATION.

NOTE

-THIS ELECTRONIC DOCUMENT IS NOT SIGNED OR SEALED BY A PROFESSIONAL ENGINEER AND MAY NOT BE USED FOR CONSTRUCTION PURPOSES
-THIS ELECTRONIC DOCUMENT IS STRICTLY FOR INFORMATION PURPOSES (OR COORDINATION AS APPLICABLE)
-NO GUARANTEES ARE GIVEN ON THE INTEGRITY OF THE TRANSMITTED INFORMATION.
-NO GUARANTEES ARE GIVEN ABOUT PAST OR FUTURE CHANGES TO THIS DOCUMENT

PLATFORM AR-130-T TECHNICAL SHEET	
TYPE	VERTICAL, CLOSED SHAFT
CODE	CSA/B355-09
RAIL LINEAR WEIGHT	5 lb/ft
MAX CAPACITY	2 PERSONS AND 1 WHEELCHAIR
MAX LOAD	750 Lb (340 Kg)
TRACTION MACHINE	LIFTING CABLES AND WINDING DRUM
MOTOR	24 VDC, 1HP
VELOCITY	23 pi/min(0.12m/s)
MAX TRAVEL	(9150 mm) (7000mm/B355)
SAFETY GEAR	SAFETY BRAKE OPERATED BY THE ACTION OF AN OVERSPEED GOVERNOR
CAB FINISHES	SEE DOCUMENT C-01
CAB	MAX. 42x66po (1067 mm x 1676 mm)
FLOOR FINISH	ANTI SKID FINISH
COMMANDS	CONSTANT PRESSURE
CONTROLLER	CSA (B355 & B44.1)
DOOR INTERLOCK	HONEYWELL (REALIGN)
TRACTION CABLES	2X AIRCRAFT 7X19 Ø1/4" MILD T 83420 7000LBS CAP

Les Escalateurs Atlas Inc.

3175 Boul. Choquette
St-Hyacinthe (Québec)
J2S 7Z8, Canada
Tél: (450) 796-5708
Fax: (450) 250-5110

TITLE: **GENERAL INFORMATION**

No. DRAWING	DATE:	REVISION
AR-130-T	02/03/2018	1
CODE:	DRAFTER:	No SHEET:
B-613	M. DEBUSSCHERE	1/1