

1 AR-130-T_A

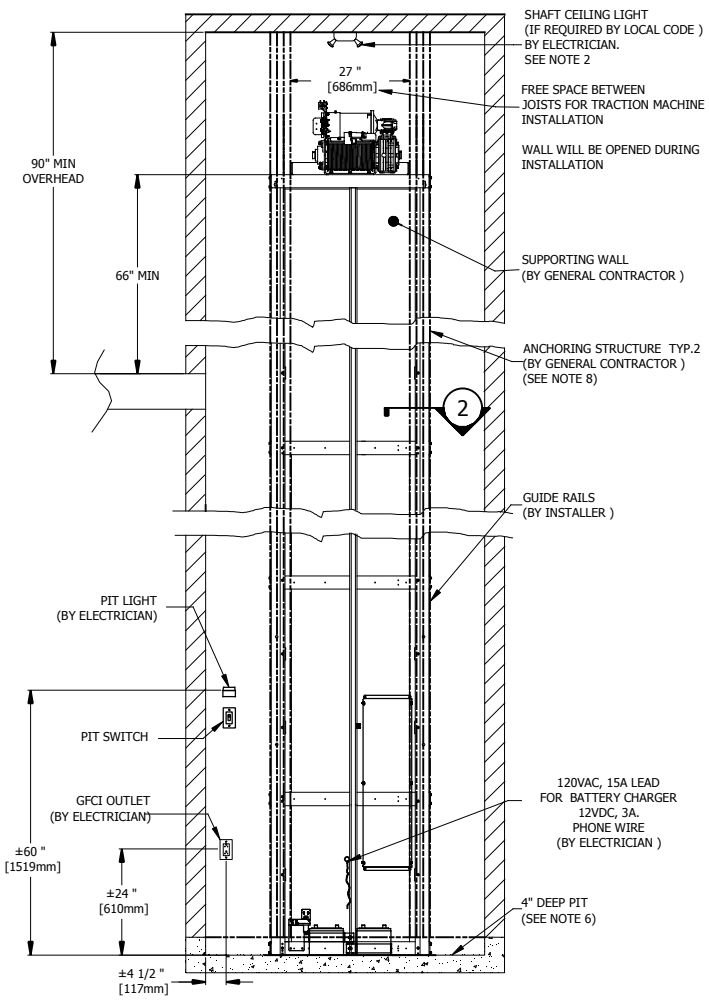

4 SUPPORTING WALL

- NOTE**
- ELEVATOR PLATFORM MODEL: **AR-130-T**
 - INSTALL 1 PERMANENT CEILING FIXTURE WITH MIN 2 BULBS (100 LUX MIN). A BULB FAILURE SHOULD NOT PREVENT THE OTHER BULB FROM LIGHTING.
 - INSTALL 1 FIXTURE AT EACH FLOOR, OUTSIDE THE HOISTWAY WITH THE SWITCH INSTALLED AS CLOSE AS POSSIBLE TO THE LANDING DOOR.
 - ROUTE TO THE SUPPORTING WALL, A 120VAC 15A WIRE FROM MAIN DISCONNECT SWITCH AT 24" FROM PIT FLOOR.
 - ROUTE ONE CIRCUIT 120VAC, 15A FROM BREAKER PANNEL FOR PIT & SHAFT LIGHTING AND IF REQUIRED, THE GFCI TYPE OUTLET IN THE PIT. OUTLET BREAKER TRIP MUST NOT COMPROMISE LIGHTING.
 - AS REQUIRED BY LOCAL BUILDING CODE, FLOOR SUPPORT TO MEET BASE LOAD AND REACTIONS REQUIRED TO SUPPORT TOWER MOUNTING REACTIONS. SUPPORTING WALL MUST BE SMOOTH, WITHOUT RECESS OR PROJECTIONS.
 - BUILDING ENGINEER OR CONTRACTOR IS RESPONSIBLE TO MEET TOWER REACTIONS REQUIREMENTS. ALL WORK AND MATERIALS MUST CONFORM WITH AUTHORITIES HAVING JURISDICTION.
 - TRIPLE STUD HEIGHT SHOULD NOT EXCEED 12' UNLESS FIXED AT EACH 12'. STUDS CAN BE SUBSTITUTED WITH DOUBLE 2x6 STUDS, 4"x4"x1/4" HSS SQUARE TUBING, OR ANY OTHER SUITABLE MATERIAL APPROVED BY THE BUILDING'S STRUCTURAL ENGINEER.
 - CHECK WITH ARCHITECT IF AUTOMATIC DOOR OPENERS ARE REQUIRED ON LOCATION.

DOOR INSTALLATION:

- THE CONSTRUCTION OF THE WALLS MUST BE DONE AFTER THE INSTALLATION OF THE LANDING DOORS.
- LEAVE A 3/4" SPACE ON EACH SIDE OF THE DOOR TO ALLOW SIDEWAY ADJUSTMENT ON SITE

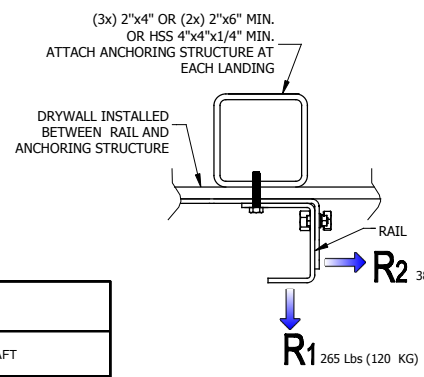

2 RAILS REACTIONS

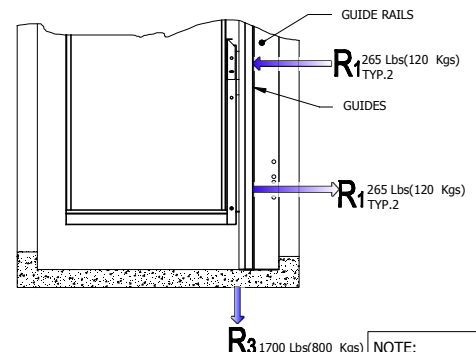

3 REACTIONS

NOTE: HOISTWAY DESIGN MUST FOLLOW A SAFETY FACTOR OF 5, SEE CAN/CSA-B355.

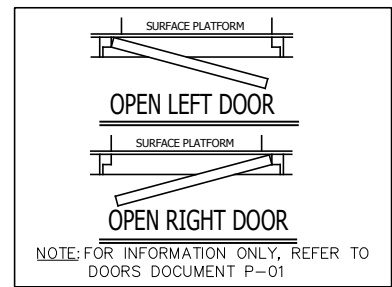

PLATFORM AR-130-T TECHNICAL SHEET	
TYPE	VERTICAL, CLOSED SHAFT
CODE	CSA/B355-09
RAIL LINEAR WEIGHT	5 lb/ft
MAX CAPACITY	2 PERSONS AND 1 WHEELCHAIR
MAX LOAD	750 Lb (340 Kg)
TRACTION MACHINE	LIFTING CABLES AND WINDING DRUM
MOTOR	24 VDC, 1HP
VELOCITY	23 pi/min(0.12m/s)
MAX TRAVEL	(9150 mm) (7000mm/B355)
SAFETY GEAR	SAFETY BRAKE OPERATED BY THE ACTION OF AN OVERSPEED GOVERNOR
CAB FINISHES	SEE DOCUMENT C-01
CAB	MAX. 42x66po (1067 mm x 1676 mm)
FLOOR FINISH	ANTI SKID FINISH
COMMANDS	CONSTANT PRESSURE
CONTROLLER	CSA (B355 & B44.1)
DOOR INTERLOCK	HONEYWELL (REALIGN)
TRACTION CABLES	2X AIRCRAFT 7X19 Ø1/4" MILD 83420 7000LBS CAP

- NOTE**
- THIS ELECTRONIC DOCUMENT IS NOT SIGNED OR SEALED BY A PROFESSIONAL ENGINEER AND MAY NOT BE USED FOR CONSTRUCTION PURPOSES
 - THIS ELECTRONIC DOCUMENT IS STRICTLY FOR INFORMATION PURPOSES (OR COORDINATION AS APPLICABLE)
 - NO GUARANTEES ARE GIVEN ON THE INTEGRITY OF THE TRANSMITTED INFORMATION.
 - NO GUARANTEES ARE GIVEN ABOUT PAST OR FUTURE CHANGES TO THIS DOCUMENT

Les Escalateurs Atlas Inc.

8255 Boul. Laframboise
St-Hyacinthe (Québec)
J2R 1E8, Canada
Tél: (450) 796-5708
Fax: (450) 796-5110

TITLE: **GENERAL INFORMATION**

No. DRAWING	AR-130-T	DATE:	12/02/2016	REVISION
CODE:	B-355	DRAFTER:	M. DEBUSSCHERE	No SHEET: 1/1