

PLATFORM AC-105 / AR-100
TECHNICAL SHEET

MAX CAPACITY	1 PERSON ON WHEELCHAIR
MAX LOAD	500 Lb (227 Kg)
DRIVE UNIT	ROLLER CHAIN AND SPOCKET
ROLLER CHAIN	ANSI/ASME B25.100
VELOCITY	19 pi/min(0.10m/s)
MOTOR	120VAC 15A (motor operates on batteries) or 120VAC 20A (power supply)
CAB AREA	VARIABLE
COMMANDS	CONSTANT PRESSURE
CONTROLLER	Bectrol BEC03 (Power : BEC04)
INCLINED ANGLE	VARIABLE
SAFETY ARMS	MOTORISED OR MANUAL
FLOOR DEPLOYMENT	MOTORISED OR MANUAL
FLOOR FINISH	ANTI SKID FINISH
CUT-OFF SWITCH	Square D CH221N/EIK031EV
WALL REACTION	300 lb AWAY SUPPORTING WALL
MOTOR	24VDC 1HP

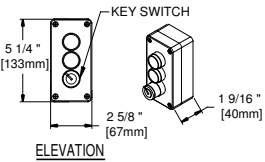
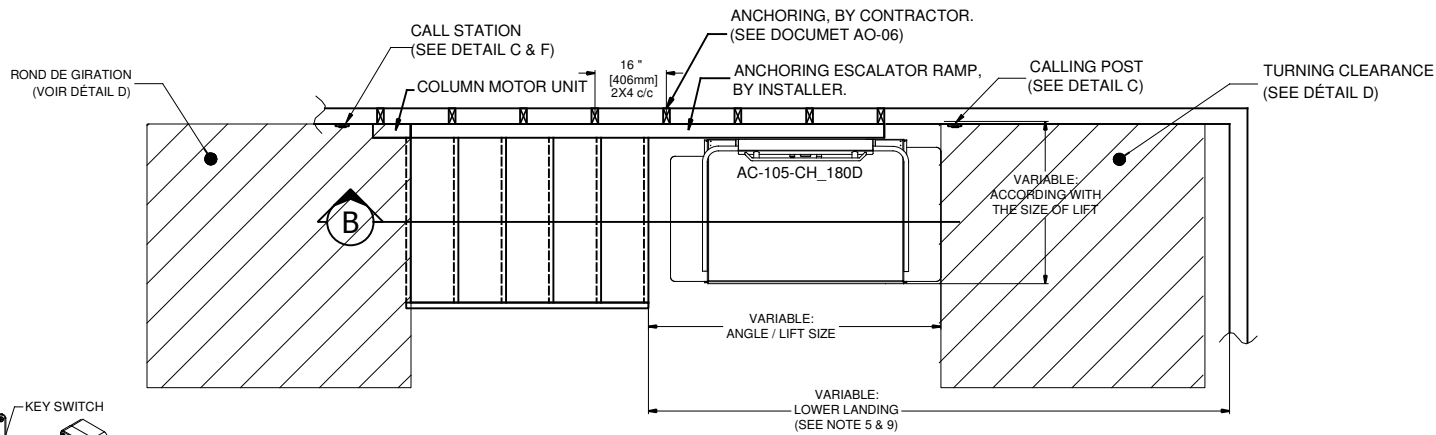

F CALL STATION
SURFACE MOUNT

FOR REFERENCE ONLY
DO NOT USE FOR CONSTRUCTION

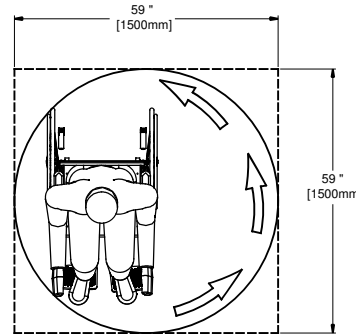

D DETAIL
TURNING CLEARANCE

- NOTE**
- THIS DRAWING COVERS THE INSTALLATION OF THE PLATFORM IN THE STAIRWAY.
 - ANCHOR THE RAIL GUIDES INTO EACH SUPPORTING WALL STUD USING 1/4" X 4" LAG SCREWS.
 - MAXIMUM DISTANCE BETWEEN SUPPORTING WALL STUDS IS 16".
 - APPLY SECTION 38 OF THE CANADIAN ELECTRICAL CODE.
 - PROVIDE A 60" FREE PIVOTING AREA AT EACH LANDING
 - PROVIDE AT LEAST 100 lx OF LIGHTING IN THE STAIRWAY, ON THE PLATFORM AND AT EACH LANDING.
 - THE OWNER HAS THE RESPONSIBILITY TO OBTAIN THE STUDIES AND APPROVALS TO ENSURE AN INSTALLATION THAT WILL CONFORM TO ALL LOCAL LAWS, CODES AND REGULATIONS, AS WELL AS ANY AUTHORITIES HAVING JURISDICTION IN THE MUNICIPALITY.
 - ADVISE THE LOCAL FIRE DEPARTMENT TO IMPLEMENT AN INTERVENTION PLAN IN CASE OF AN EMERGENCY.
 - VERIFY THE VARIOUS CLEARINGS, EMERGENCY EXITS, AS WELL AS THE IMPLEMENTATION OF THE PLATFORM INSIDE YOUR BUILDING WITH PROFESSIONALS SUCH AS ARCHITECTS, STRUCTURAL ENGINEERS AND ERGOTHERAPISTS.

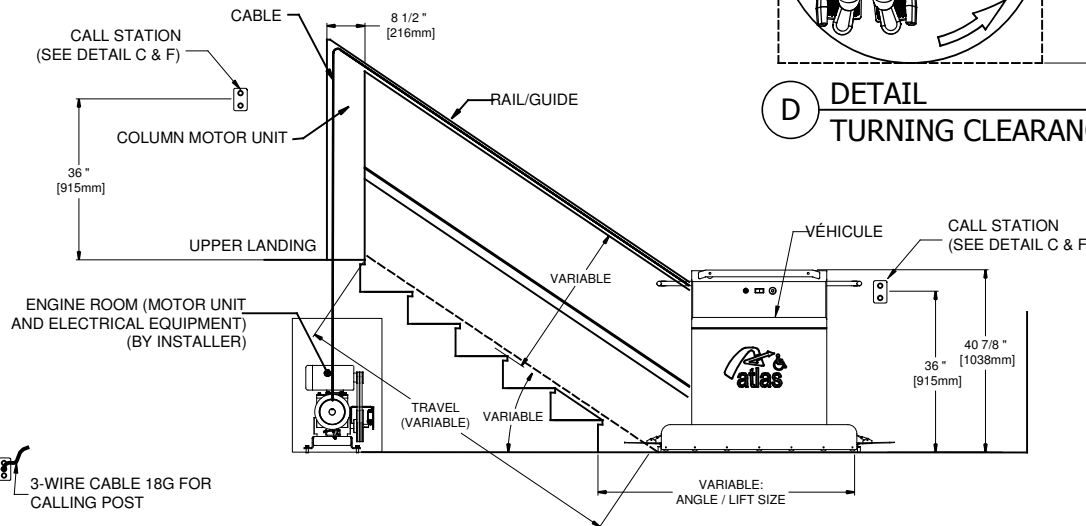

B ELEVATION VIEW

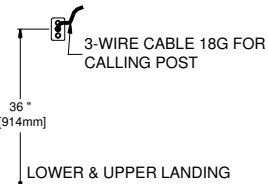

C ELECTRICAL DETAIL

NOTE: TAKE WHEEL CHAIR DIMENSION WHEN PLATFORM IS UNDER 30" WIDTH

PROJECT:
GENERAL INFORMATION



Les Escalateurs Atlas Inc.
3175 Boul. Choquette
St-Hyacinthe (Québec)
J2S 7Z8, Canada
Tél: (450) 796-5708
Fax: (450) 250-5110

CONFIGURATION DETAILS			
Code:	B-613 & B-355		
Lift cage:	42" HEIGHT	No Drawing:	
Drafter:	M. Debusschere	AR-100 / AC-105_180 R_TYP (WITH ENGINE ROOM)	
Date:	03-16-2018	No:	AO-05
Status:	INFORMATION	No Sheet:	1/1
Revision:	2		