

Power Hockey Side Score Setup & Assembly Instructions



20 Providence Pike
North Smithfield, RI 02896
800-831-2011 • (f) 401-463-6673
www.GreatAmericanRec.com
games@greatamericanrec.com

Thank You for purchasing the Great American Recreation *Coin Power Hockey Table*. It is designed to withstand many thousands of plays in a commercial environment (i.e. bar, video game/amusement center, etc.). We are confident that it will provide years of enjoyment in your location.

Parts List

The following parts should be included with the *Power Hockey Table*:

- 4 Legs with attached levelers (located in separate box)
- 16 1 1/2" x 3/8" #16 bolts (attached to inside of trap door)
- 10 Keys (amount may vary)
- 2 Mallets
- 1 Puck
- 1 Score Panel
- 4 1/4" #20 bolts

Setup Instructions

1. Locate key taped to *Power Hockey Table* coin mechanism.
2. Open trap door on the bottom of the *P.H. Table*.
3. Remove 4 legs with levelers and a bag of (16) bolts inside leg box.
4. Attach legs to bottom of table using (16) 1 1/4" x 3/8" #16 bolts. (See Figure 1)
5. Stand table upright.
6. Open *Power Supply Access Door* (see Figure 2).
7. Locate bag stapled to door containing (4) 1/4" #20 bolts.
8. Using those bolts, attach *Score Panel* to side of table with taped wire.

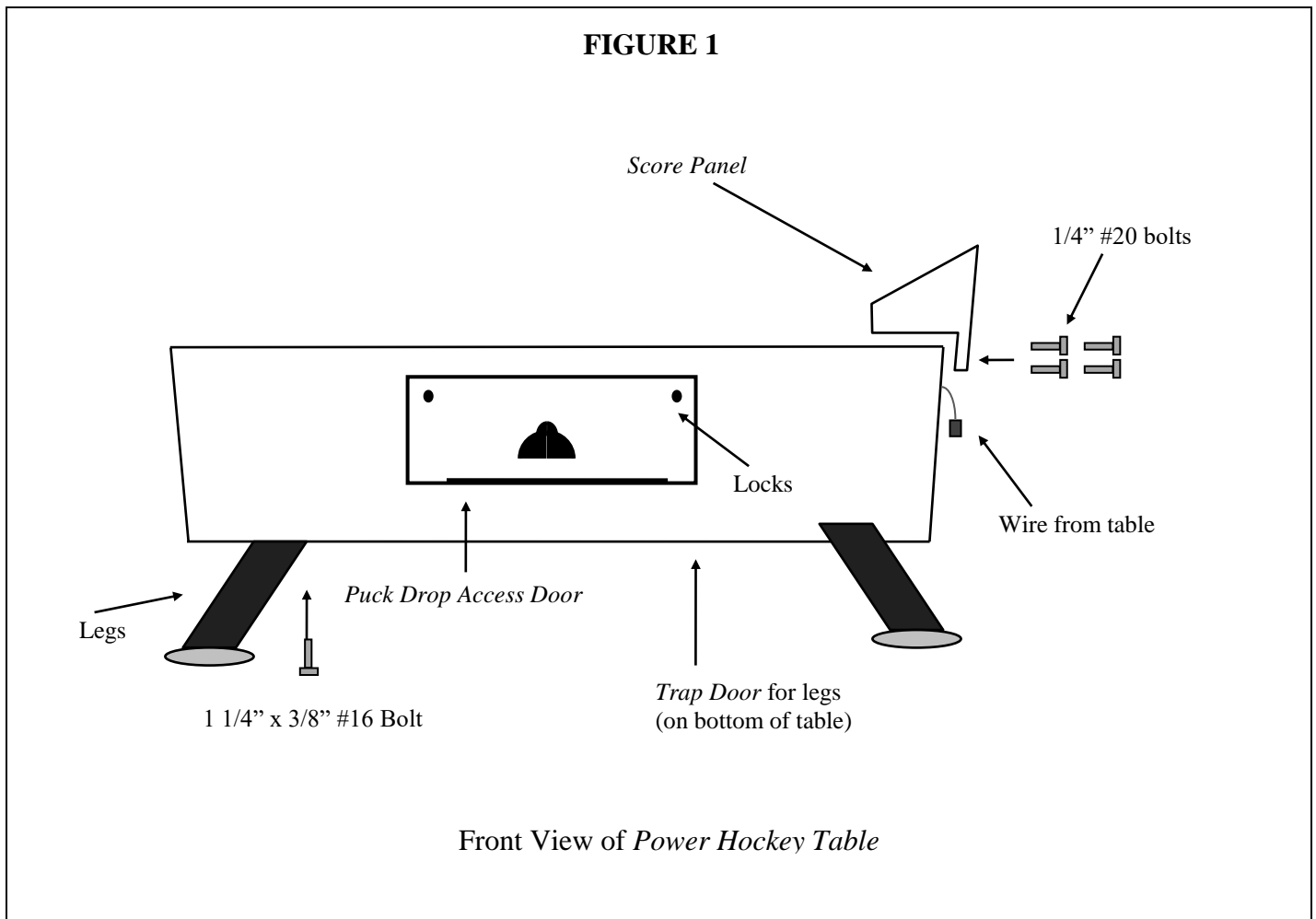

9. Connect Wire from table to connector marked "Interface" on the back of the *Score Panel*.

NOTE: Make sure the notch on the wire harness faces the center of the circuit board.

Setting up the Game Options

The *Power Hockey* game has the following factory set defaults:

1 coin, mechanism throw allows 1 game with a maximum game time of 7 minutes

To change these settings, you must change the DIP switches located on the *Logic Board* which is behind the *Power Supply Access Door*. Refer the DIP switch setting sheet attached to the inside of the *Power Supply Access Door* (see Figure 2).

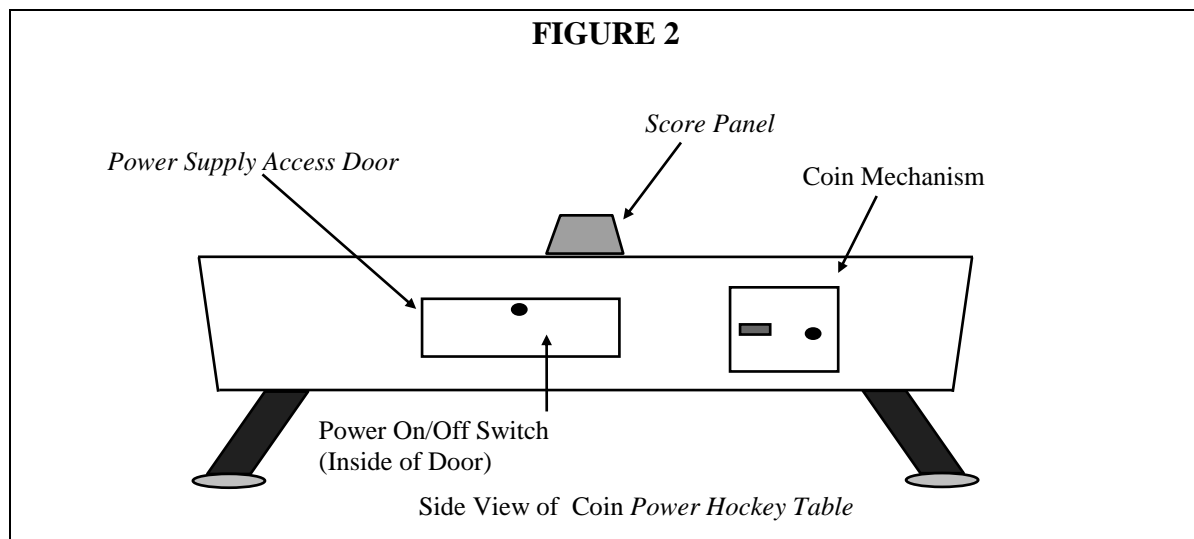

Puck Drop Access Doors

Locate the *Puck Drop Access Door* on either end of the *H.P.H. Table*. These doors can be opened, using the keys provided, to remove the any foreign objects which may fall into or obstruct the puck in the *Return Chute* (see Figure 1).

GREAT AMERICAN RECREATION EQUIPMENT, INC.
 110 POWER SUPPLY BOX DIAGRAM

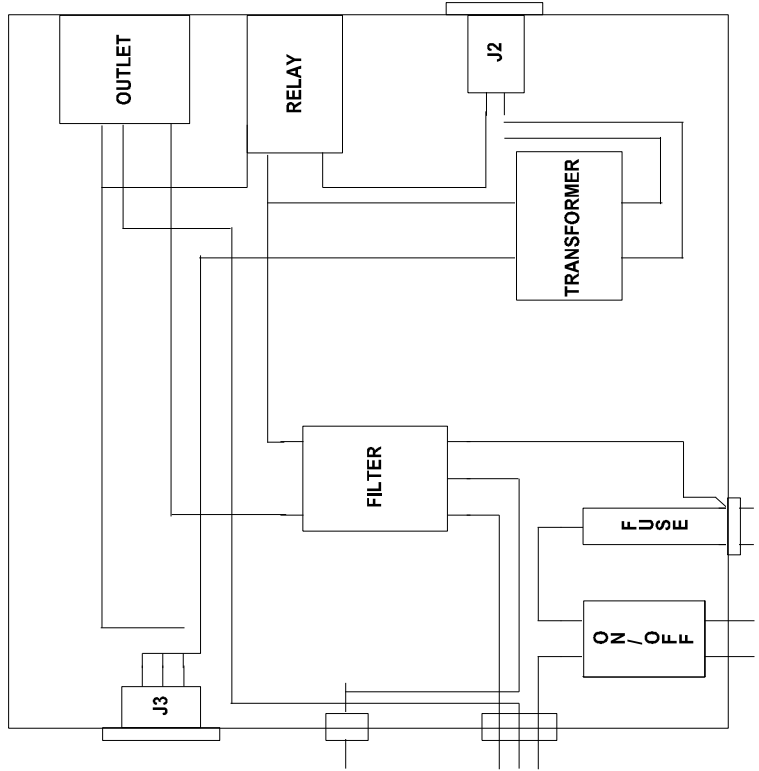
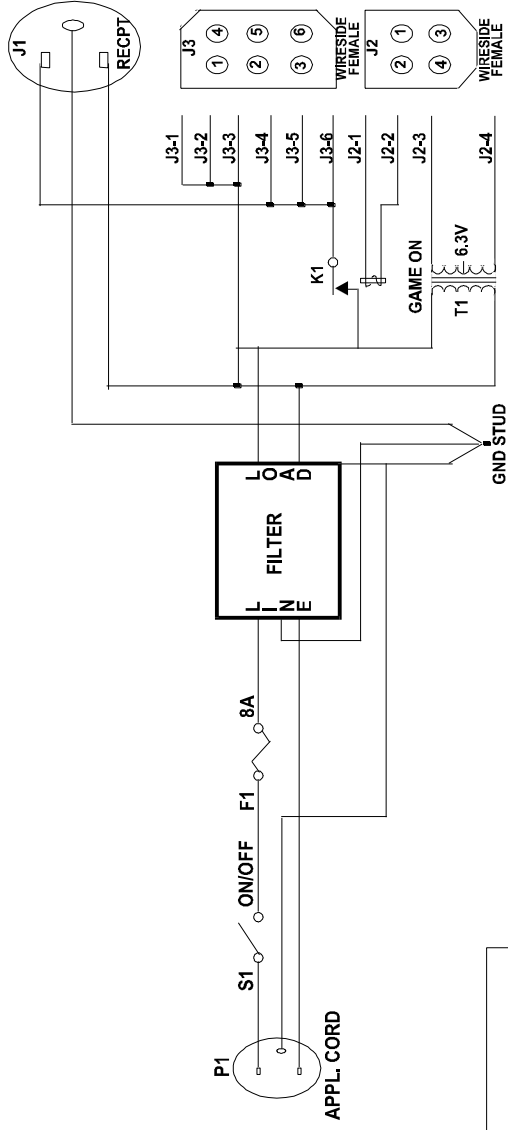

DIP Switch Settings

AH2004(V1.05)									
Description	Value	DIP Switch Number 1							
		1	2	3	4	5	6	7	8
End Of Play Score	6	0	0						
	7*	1	0						
	8	0	1						
	9	1	1						
End Of Play Timer (Minutes)	6			0	0				
	9*			1	0				
	12			0	1				
	15			1	1				
Coins Per Play If using a slide mech this is set to one and the slide determines the pricing.	1*					0	0	0	
	2					1	0	0	
	3					0	1	0	
	4					1	1	0	
	5					0	0	1	
	6					1	0	1	
	7					0	1	1	
	8					1	1	1	
Coin Slide or Drop Mech	Coin Slide*								0
	Drop Mech								1
* Denotes factory Setting									
AH2004(V1.05)									

Description	Value	DIP SW 2			
		1	2	3	4
DBA Factor What should the pulses out of the DBA be divided or multiplied by to equal one coin.	1*	0	0	0	
	2	1	0	0	
	3	0	1	0	
	4	1	1	0	
	5	0	0	1	
	6	1	0	1	
	7	0	1	1	
	8	1	1	1	
Multiply or Divide Pulses	MULTIPLY*				0
	DIVIDE				1
* Denotes Factory Setting					

Connector Pin Outs

Pin

#1 is left hand pin facing connector and has square solder pad.

<u>Connector</u>	<u>Pin#</u>	<u>Function</u>
J2 (DBA Port)	1	+12VDC to DBA
	2	GND to DBA
	3	N/C (Key)
	4	Coin 2 Input from DBA
	5	+5VDC for DBA EN+
	6	GND for DBA EN-
J3 (Sound Port)	1	+12VDC to Sound Board
	2	TXD to Sound Board
	3	GND to Sound Board
	4	RXD from Sound Board

J1 Edge Connector Pin Out			
Top (Parts Side)		Bottom (Solder Side)	
AC IN 1	1	2	N/C
AC IN 1	3	4	Coin 2 Switch
AC IN 2	5	6	DC Ground
AC IN 2	7	8	DC Ground
N/C	9	10	Start Switch(N/U)
DC Ground	11	12	Left Puck Switch
DC Ground	13	14	Right Puck Switch
DC Ground	15	16	Coin 1 Switch
+12VDC	17	18	Credit Lamp(N/U)
+12VDC	19	20	Motor Relay
+12VDC	21	22	Counter 1
+12VDC	23	24	N/C
Counter 2(N/U)	25	26	+5VDC
KEY	27	28	KEY
DC Ground	29	30	N/C

Puck Lockout Solenoid Installation

1. Remove the side covers from the overhead score unit by removing two phillip screws on each end cap.
2. Disconnect the 3 wire connections for the overhead score unit.
3. Remove overhead score unit by removing 4 bolts in the side mounting bracket.
4. Open the side door and unplug the black blower cord (*very important*) which is located on the side of the power supply unit.
5. Remove all screws around the top outside edge of the table (located below the top rails) and remove top rails and play field.
6. At each goal end, inside the table, are the puck lock out solenoids. Remove the 2 bolts and 3 wires (black, white & green). Before removing wires, please note the position of each wire for re-assembly
1. Then install new solenoids and reassemble table using the steps above as a guide.