

REESE™ Return Box  
item: SRB1E

REESE™ Track Profile  
item: RT1E

REESE™ Motor Box  
item: SMB1E

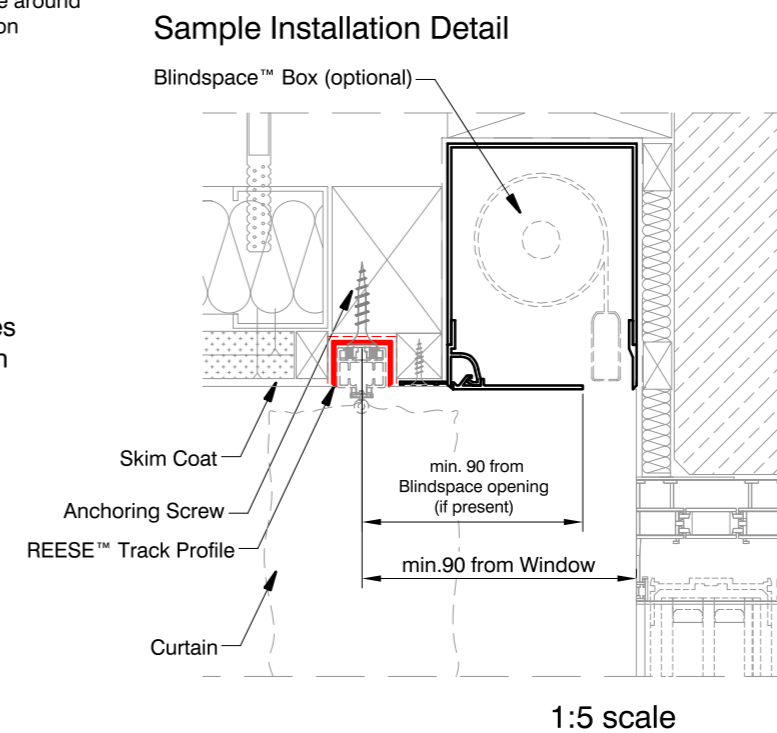
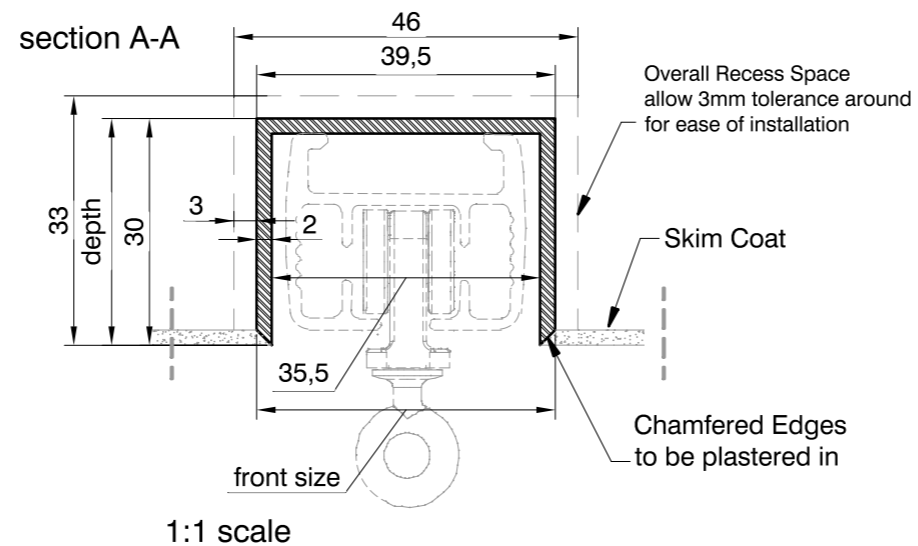
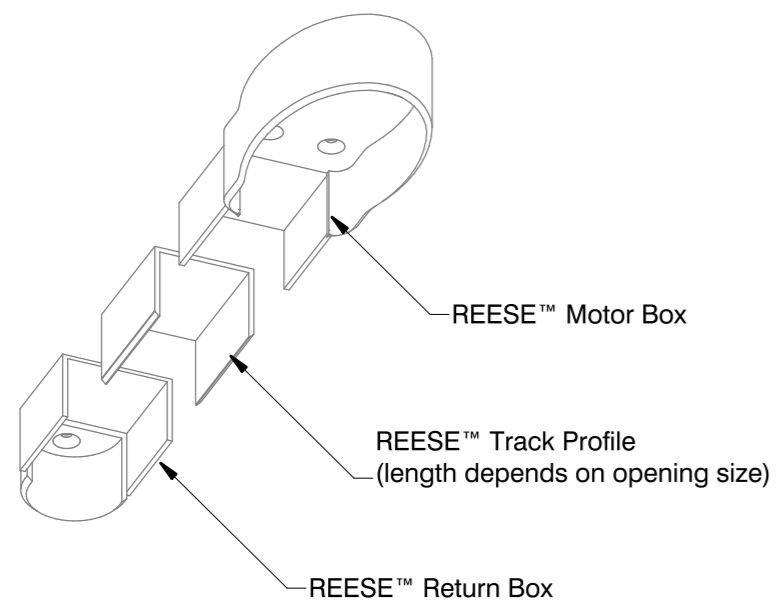

Product	Reese S1E
Description	Recessed profiles to house curtain tracks
Material	U-profile: Anodized Aluminium, grade: EN 6060 T66 End cap: Plastic POM Polymer
Finishes	White to be plastered in and decorated at site to match ceiling.
Tracks sizes	Curtain Tracks Sizes to fit inside the profiles: space available for third party track profile: W35xH27
Installation	Anchoring with countersink screws through profile walls near the center of profiles are recommended. The finished plaster level should be flush with chamfered edge.
Drawing	Standard Reese Track system S1E
Item name	RT1E, SMB1E, SRB1E
Notes	Dimensions in mm Do not scale from drawing
Drawn by	M. Kozak
Approved	A. Sundelin
Revision	change: date: R-01 first issue 2018-01-11 R-02 naming change 2018-04-17

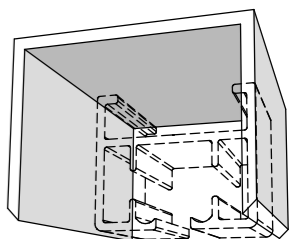

Print date	2018-01-11
Print file	reese s1e v01.dwg
Page size	ISO A3 420x297
Remarks	

REESE™