

1. THIS DRAWING IS FOR PRELIMINARY PURPOSES ONLY. ALL COLUMNS AND/OR DIMENSIONS SHOWN REFLECT PRELIMINARY LOCATIONS. FINAL CONDITIONS TO BE FIELD VERIFIED BY TENANT.
 2. GRAPHICS ILLUSTRATING PROPOSED SIGN LOCATIONS ARE FOR REFERENCE ONLY. ALL TENANT SIGNAGE IS SUBJECT TO APPROVAL PER THE TENANT SIGN CRITERIA.

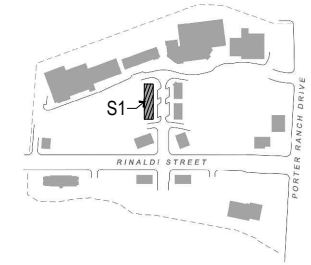

KEY PLAN

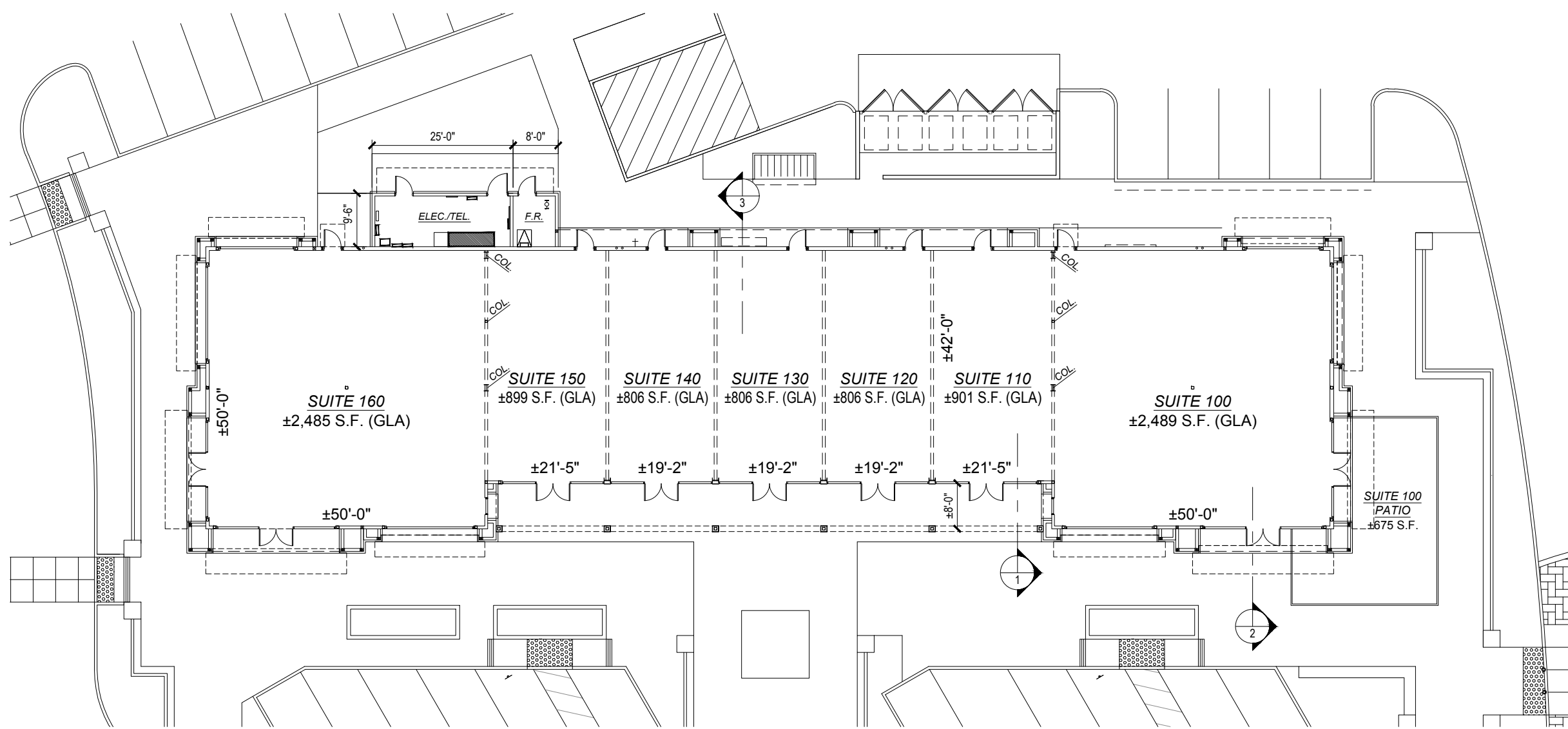

FLOOR PLAN

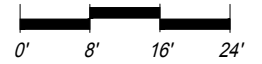

ARCHITECTS
ORANGE



THE VINEYARDS AT PORTER RANCH
 PORTER RANCH DRIVE AND RINALDI STREET
 LOS ANGELES, CA 91326

20165 W. RINALDI ST.
 (BLDG. S1)

Project Number: 2015-157 Date: 05-16-17
 Plan Check Number:

REVISION	05-07-16
REVISION	05-08-16
REVISION	05-20-16
REVISION	02-15-16
REVISION	01-21-16
REVISION	05-16-17

© 2015 Architects Orange. This drawing is for preliminary purposes only and is not to be used for construction. The architect and its affiliates shall not be responsible for the accuracy of the information provided by the client.

1. THIS DRAWING IS FOR PRELIMINARY PURPOSES ONLY. ALL COLUMNS AND/OR DIMENSIONS SHOWN REFLECT PRELIMINARY LOCATIONS. FINAL CONDITIONS TO BE FIELD VERIFIED BY TENANT.
2. GRAPHICS ILLUSTRATING PROPOSED SIGN LOCATIONS ARE FOR REFERENCE ONLY. ALL TENANT SIGNAGE IS SUBJECT TO APPROVAL PER THE TENANT SIGN CRITERIA.

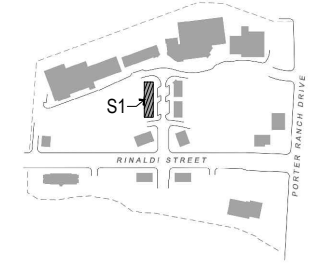

THE VINEYARDS AT PORTER RANCH
 PORTER RANCH DRIVE AND RINALDI STREET
 LOS ANGELES, CA 91326

**20165 W. RINALDI ST.
 (BLDG. S1)**

Project Number: 2015-157 Date: 05-16-17

Plan Check Number:

REVISION 12-21-16

REVISION 05-16-17

REVISION

REVISION

REVISION

REVISION

REVISION

REVISION

REVISION

REVISION

REVISION

REVISION

REVISION

REVISION

REVISION

REVISION

REVISION

REVISION

REVISION

REVISION

REVISION

REVISION

REVISION

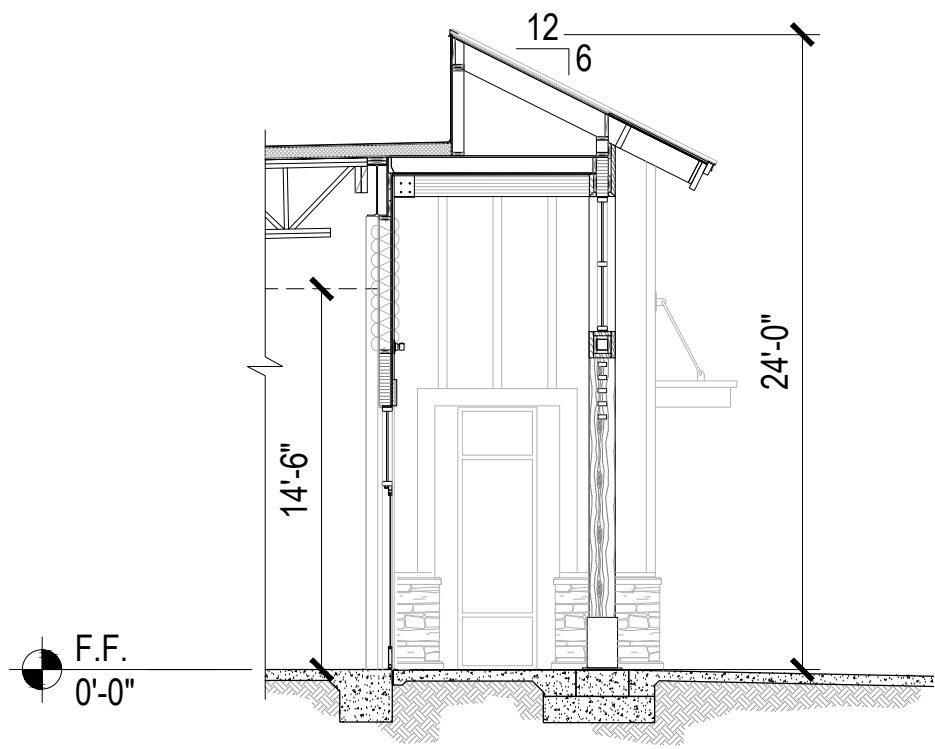
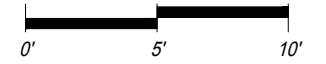

SECTION 2

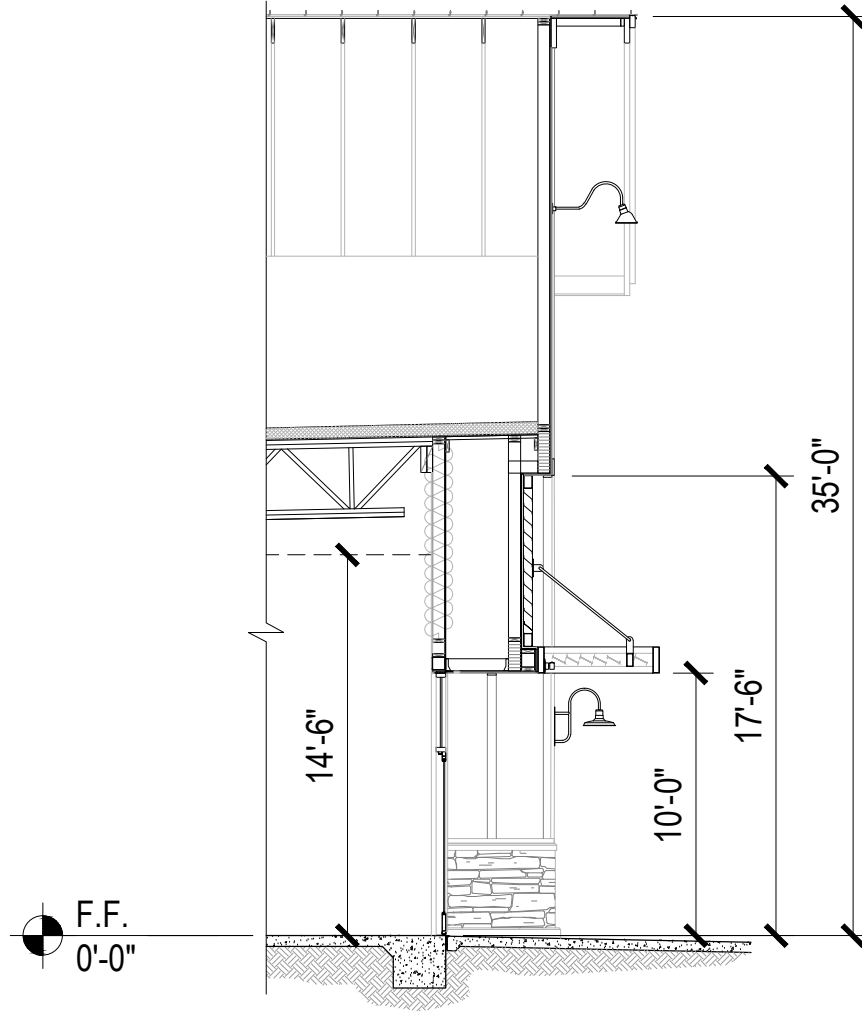

SECTION 2

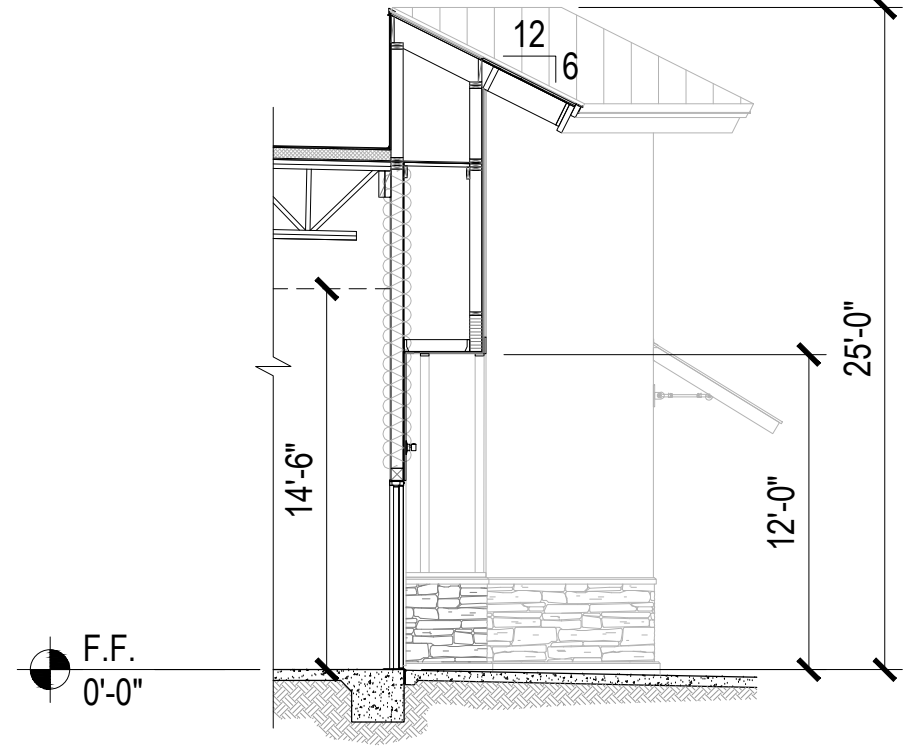

SECTION 3

BUILDING SECTIONS