

# Air Cylinder Specifications

## APPENDIX D

### Numatics Cylinders

#### Diagrams

Pneumatic Service Temperatures:  
 Nitrile Seals: -10°F (-23°C) to 165°F (74°C)  
 Viton® Seals: 0°F (-17°C) to 400°F (204°C)

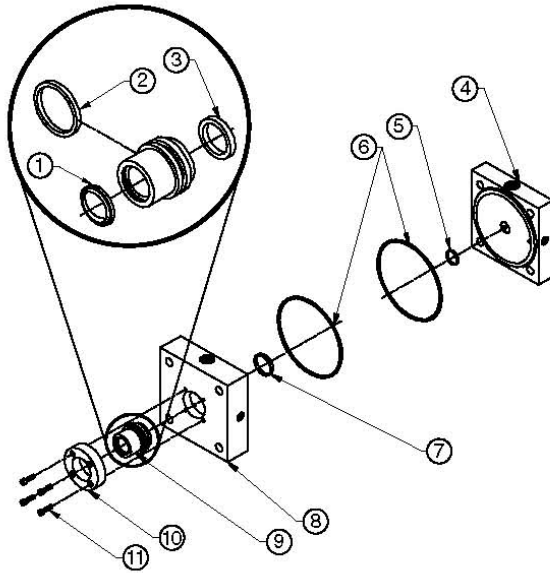

Head, Cap, and Bushing Assembly

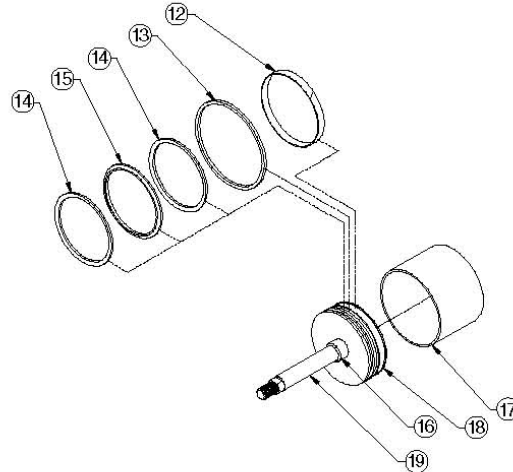

Piston/Rod Assembly

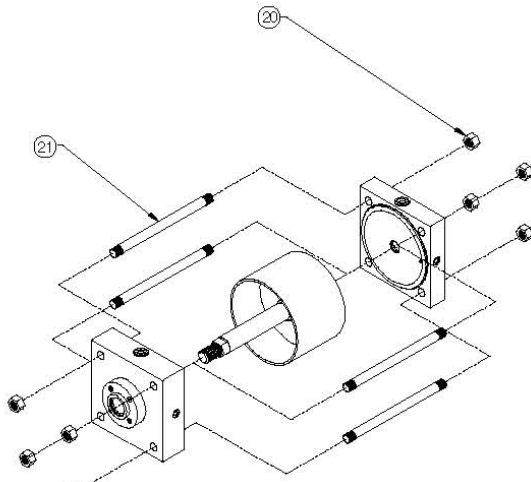

Cylinder Assembly and Tie Rod Torque

#### A Series

Part #	Description	Parts included in:		
		Seal Kit	Repair Kit	Piston/Rod Assembly
1	Rod Wiper	X		
2	Bushing O-ring	X		
3	Rod Seal	X		
4	Cap			
5	Cap Cushion Seal	X	X	
6	Tube End Seals	X	X	
7	Head Cushion Seal	X	X	
8	Head			
9	Loaded Bushing Assembly		X	
10	Bushing Retainer			
11	Retainer Screws			
12	Wearband	X	X	
13	Magnet			X
14	Back-up Rings	X	X	
15	Piston Seal	X	X	
16	Cushion Spear			X
17	Tube			
18	Piston			X
19	Rod			X
20	Hex Nuts			
21	Tie Rods			

# Air Cylinder Specifications

## APPENDIX D

### Numatics Cylinders

#### Seal Installation Guide

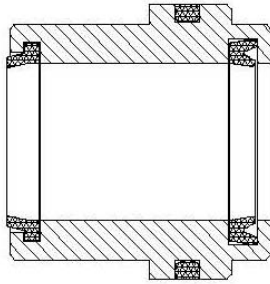

Loaded Bushing

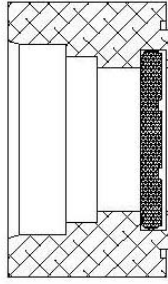

Cushioned Head or Cap

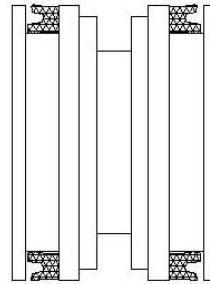

Low Breakaway Piston

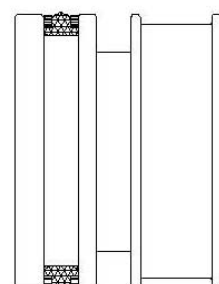

T-Seal Piston

#### Torque Tolerances (LBS-FT) Tie Rod Nut Part #20

Bore	Min.	Max.
1-1/2"	8	10
2"	15	20
2-1/2"	15	20
3-1/4"	23	30
4"	23	30
5"	50	60
6"	50	60
8"	80	90
10"	200	220
12"	200	220
14"	300	330

#### Retainer Screws Torque Tolerances (lbs-ft) Part #11

Size	Min.	Max.
#10-32	1	1.5
1/4-28	5	7
5/16-24	10	12

**Note:** Sinker Tubes are not included in kits.  
They can be ordered using the part numbers  
from the provided chart.

#### Sinker Tube Part Numbers

Bore	Part #
1-1/2"	A06-K91
2"	A06-L91
2-1/2"	A06-P91
3-1/4"	A06-M91
4"	A06-R91
5"	A06-T91
6"	A06-U91
8"	A06-W91
10"	A06-X91
12"	A06-Y91
14"	A06-B91

# Air Cylinder Specifications

## APPENDIX D

### Numatics Cylinders

---

#### **Piston Rod Assembly Kit Installation Instructions**

1. Loosen 4 Tie Rod Nuts (Part #20) to remove Piston/Rod Assembly (Part #18 & #19).
2. Carefully remove seals. (Part #12, #14, & #15). Any damage to the seals may result in leakage.
3. Lubricate piston seal(s) and wearband (Part #12) with supplied Numatics' Lube. Examine seals before installing for any contamination. Contamination may cause leakage.
4. Install Piston Seal (Part #15). Make sure the piston seal is not twisted inside groove. Next install back-up rings if piston seal is a T-seal.
5. Install lubricated wearband onto piston. Sink piston/rod assembly into sinker tube.
6. Apply lube inside the cylinder tube (Part #17).
7. Sink piston/rod assembly into cylinder tube.
8. Press piston/rod assembly flush with the cylinder tube. Wipe off any lube from the face of the piston.
9. Examine all seals before reassembling cylinder for any contamination. Contamination may cause leakage.
10. Lightly grease Rod Seal (Part #3) of Loaded Bushing before installing. This will ease the installation of the rod bushing over the rod.
11. Reassemble cylinder. Loosely torque Tie Rod Nuts (Part #20) to allow head and cap to rotate slightly.
12. Before final torque, place cylinder on level surface. This will ensure that the cylinder head and cap are square. Torque Tie Rod Nuts (Part #20) in a crisscross pattern. Use torque tolerances chart for Tie Rod Nuts and Retainer Screws.
13. Stroke cylinder by hand. This will enable detection of any binding. If binding does occur, repeat steps 11-13.

See Seal Installation Guide on page 41 for additional (visual) instructions.

#### **Repair Kit and Seal Kit Removal/Installation Instructions**

1. Loosen 2 or 4 Retainer Screws (Part #11) to remove Loaded Bushing (Part #9)
2. Loosen 4 Tie Rod Nuts (Part #20) to remove Piston/Rod Assembly (Part #18 & #19)
3. Carefully remove old seals. (Part [#1, #2, #3 Seal kit only], #5, #6, #7, #12, #14, & #15) Any damage to the seal grooves may result in leakage.
4. Lubricate new seals with supplied Numatics' Lube. Examine seals before installing for any contamination. Contamination may cause leakage.
5. Install Piston Seal (Part #15). Make sure the piston seal is not twisted inside groove. Next install back-up rings (Part #14) if piston seal is a T-seal.
6. Install lubricated Wearband (Part #12) onto piston. Sink piston/rod assembly into sinker tube.
7. Apply lube inside the cylinder tube.
8. Sink piston/rod assembly into cylinder tube.
9. Press piston/rod assembly flush with the cylinder tube. Wipe off any lube from the face of the piston.
10. Place Tube End Seals (Part #6) into head and cap seal grooves. Examine seals after installing for any contamination. Contamination may cause leakage.
11. Install Rod Wiper (Part #1), Bushing O-ring (Part #2), and Rod Seal (Part #3) into bushing (Seal Kit only). Lightly grease Rod Seal and Bushing O-ring after installation. This will ease the installation of the rod bushing over the rod and into the head.
12. Reassemble cylinder except for loaded rod bushing (Part #9). First, loosely torque Tie Rod Nuts to allow head and cap to rotate slightly. Carefully place bushing over the rod until getting interference. With a twisting motion, slide the bushing down onto the rod and into the bushing pocket on the head.
13. Place Bushing Retainer (Part #10). Lightly tighten Retainer Screws (Part #11).
14. Before final torque, place cylinder on level surface to square head and cap. Torque Tie Rod Nuts in a crisscross pattern. Use the following charts for torque tolerances for Tie Rod Nuts and Retainer Screws.
15. Stroke cylinder by hand. This will enable detection of any binding. If binding does occur, repeat steps 12-14.