

No.	DATE	DESCRIPTION	REV
△	2016. 03. 29	Drawing revised (圖面修正)	A

REMARK : RoHS REQUIREMENT APPLIED  
(符合RoHS)

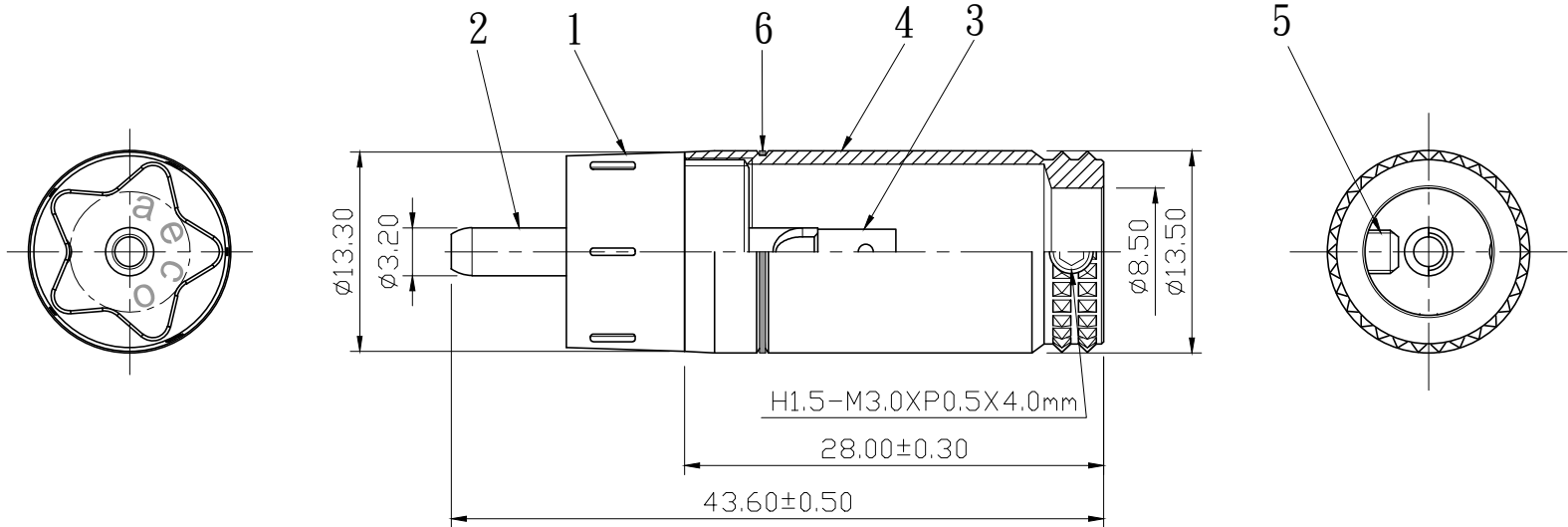

Note :  
The recommended soldering temperature :  
-Use temperature-controlled soldering iron and keep 380°C for about 5~8 seconds.  
-Use temperature-controlled soldering iron and keep 360°C for about 9~13 seconds.  
-Use temperature-controlled soldering iron and keep 340°C for about 13~18 seconds.  
-Use temperature-controlled soldering iron and keep 320°C for about 19~25 seconds.



S 1 : 1

7						DIMENSIONS ARE IN MILLIMETERS UNLESS OTHERWISE SPECIFIED TOLERANCES (一般公差) 0.5~6 = ±0.2 >6~30 = ±0.4 >30~120 = ±0.6 >120~315 = ±1 >315~1000 = ±1.6 ANGLES(角度) = ±5°	CHECKED	 雅鈦企業有限公司 Aec Connectors Co., Ltd.	
6	color ring	1	PVC	red/white			DRAWN <i>Jim</i>		TITLE RCA PLUG
5	screw	1	iron	nickel	SCREW-201N-M3XP0.5X4.0mm				DATE 2013. 05. 28
4	shell	1	brass	zinc alloy				FILE NO. DRAWING\AUDIO\RP\RP-4042ZARD/WEG(Tc)-A-8.5	
3	solder tab	1	copper	gold(10 μ")					
2	contact pin	1	tellurium copper	gold(10 μ")					
1	body	1	nylon	red/white					
NO.	Description	Unit	Materials	Finish	Drawing No.	SCALE 2 : 1	UNIT MM		