

MEASURING HIGH TEMPERATURES WITH IMMERSION THERMOWELLS

Like ordinary thermocouples, the high temperature IRt/c models can be used with immersion “thermowells” to measure high temperature gases or liquids, while maintaining the integrity of the vessel. However, the IRt/c has significant advantages over ordinary thermocouples, RTDs, etc. in this application.

Survivability

Since the IRt/c sensor elements are positioned in a non-contact mode, outside of the heated area, and kept at a low temperature, the entire temperature sensing system can be designed to survive for a much, much longer period of time than conventional thermocouples or RTD’s. The only part requiring maintenance is the thermowell itself, an inexpensive and easily replaced part. Users enjoy savings because there are no replacement thermocouple parts, no replacement labor, and no production losses from downtime for sensor replacement.

Sensor Stability and “Drift”

Even worse than sensor failure is a sensor that reads incorrectly, feeding inconsistent or inaccurate information to your control systems. Sensor stability and drift can be significant problems with standard thermocouples when measuring high temperatures, due to chemical and metallurgical changes that long exposure to high temperatures causes. The IRt/c, however, is essentially immune to those effects, since the sensor remains at a low temperature – far below that of the contact device, and below the levels which are the major sources of drift.

Sensor Speed

With its 0.1 to 0.2 second response time, the IRt/c is far faster than any conventional thermocouple or RTD placed inside a well. Accordingly, for all practical purposes, the temperature measurement speed is the same as that of the well itself.

How To Use The IRt/c With A Thermowell

The technique is to mount an IRt/c sensor so that it aims directly into a hollow thermowell. The well should have a minimum inner diameter to accommodate the minimum spot size of the sensor selected. Choose the appropriate sensor for the temperature range and length of the well you are using.

For example, to measure up to 2000°F (1100°C), 6 feet (2 m) into a stack, use an IRt/c.100A-HiE sensor looking into a thermowell of that length with an inside diameter of at least .8 inches (20 mm). The spot diameter for the IRt/c.100A at 72 inches distance is .8 inches (at 2 meters distance, the spot diameter is 20 mm.) The sensor can then “see” all the way into the hollow well tube and monitor the tip end temperature, ignoring the sidewall temperatures.

Choose appropriate thermowell material (stainless steel, Hastelloy®, Inconel®, ceramic, etc.) to withstand the temperature, oxidation and other rigors of the environment where it is to be placed.

If the thermowell is sealed with a sight glass, then a *Lo E* model should be specified (see Tech Note No. 66).

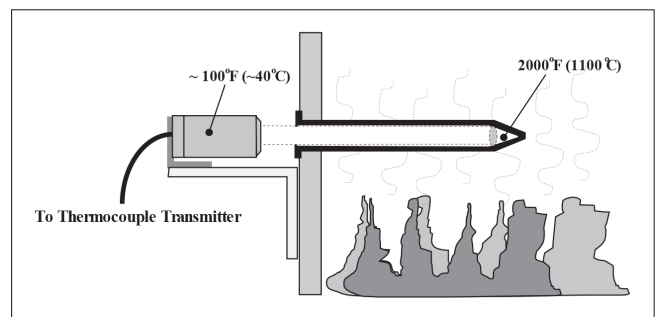

Exergen Global offices:

The Netherlands
Pastoor Clercxstraat 26
5465 RH Veghel
Tel: +31(0) 413 37 65 99
Fax: +31(0) 413 37 93 10

USA
400 Pleasant Street
Watertown, MA 02472
Tel: +1 617 649 6322
Fax: +1 617 923 9911

office@exergenglobal.com
www.exergenglobal.com