

MICRO IRTC™ INFRARED TEMPERATURE SENSOR - COLD JUNCTION AND AMPLIFICATION DESIGN NOTES OF OEMS

Overview

The purpose of this document is to present a low cost method for an OEM to accurately acquire temperature measurements using the Micro IRt/c™. In no way does this document cover every possible difficulty an engineer might encounter when undergoing development. However, the document will give the engineer a basic understanding of the techniques available to get them started. We assume that the engineer is already familiar with thermocouples and Exergen IR Thermocouples. The circuit presented is perfect for interfacing between the Micro IRt/c™ and off the shelf controllers or microprocessors (MPUs).

Circuits

Exergen proposes starting with two simple circuits. These circuits may need modification or elimination depending on the needs of the project. The first circuit regulates power for the second portion; the cold junctions and amplification of the Micro IRt/c™ signal.

Power Supply

The cold junction and amplification portion of the circuit requires 15V to run the amplifiers and output stage. Other voltages could be used, depending on the temperature range of interest. The cold junction circuit uses a 1.2V reference. This reference needs to be stable, as noise and drift will affect overall performance. If these voltages are not appropriate for your application, please contact Exergen Global for alternatives.

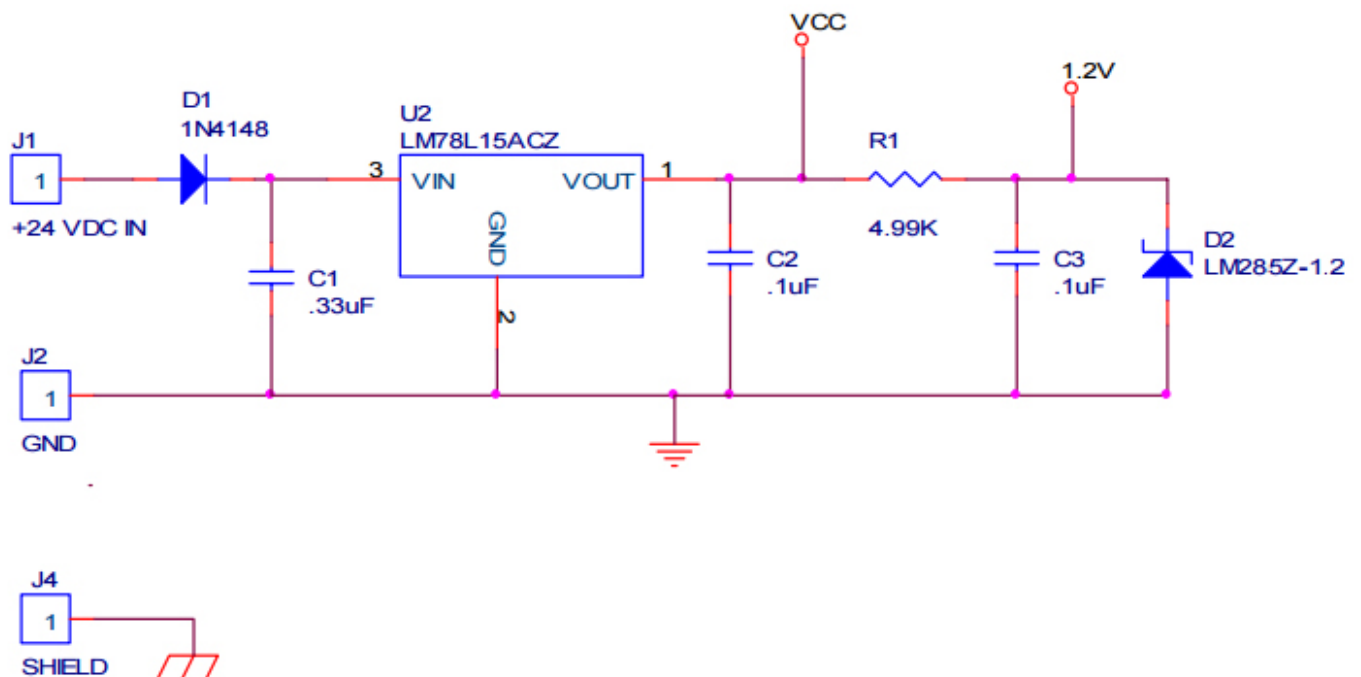

Cold Junction and Amplification

This circuit is composed of two parts; the cold junction and the amplification. Depending on what ambient temperature range and target temperature range is required for the application, component values within the circuit can be varied. We have proposed three circuit configurations. These are good starting designs and should work for 90% of application. If you need something different, please contact Exergen Global and we can make up a new design for your application.

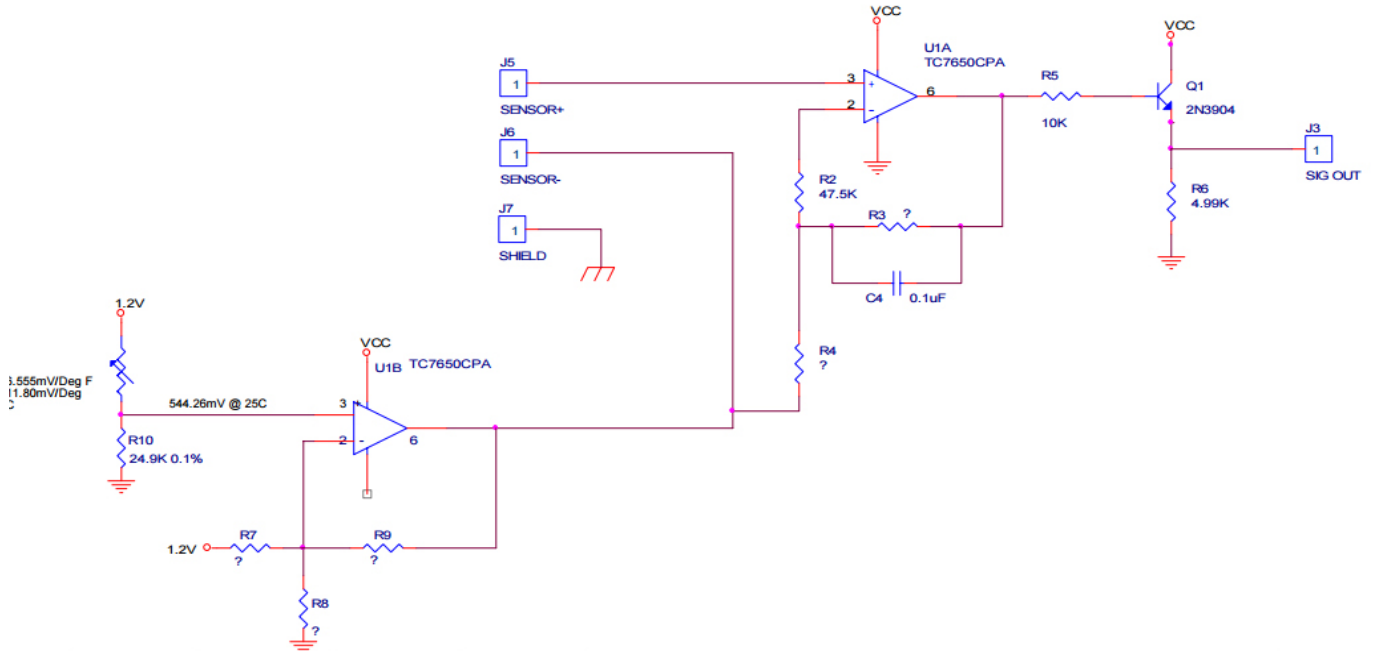

Target Range Degrees C		Voltage Output Range (V)		Ambient Range Degrees C		uIRt/c Model Designed For	Component Values						
Low	High	Low	High	Low	High		R2	R3/R4 Gain Ration	R7	R8	R9	R10	Rth
0	250	0	10	0	50	Any	Impedance Match, see Chart	981	61.9K	24.9K	41.2K	24.9K 0.1%	30K - EX813005
0	100	0	10	0	50	UIRt/c-K-180F		2083	39.2K	5.36K	35.7K	24.9K 0.1%	30K - EX813005
0	100	0	10	0	50	Any		2443	33.2K	6.19K	38.3K	24.9K 0.1%	30K - EX813005

Cost

Cost is obviously a very important issue. Here is a rough bill of materials with cost estimates. The components cost are taken from a major on-line distributor, so it is likely one can do better if they look around.

Micro IRT/c Cold Junction and Amplification Circuit

Cost in US Dollars

Component Name	Part Number/Description	Quantity per Unit	100 parts	Extended	1000 parts	extended
Voltage Regulator	LM78L15ACZ	1	0.2378	0.2378	0.123	0.123
Diode	1N4148	1	0.0675	0.0675	0.02438	0.02438
Voltage Reference	LM285Z-1.2	1	0.86	0.86	0.559	0.559
Amp	TC7650CPA		2.98	5.96	5.96	5.96
Transistor	2N3904	1	0.1235	0.1235	0.0513	0.0513
Resistors	1%	9	0.04135	0.37215	0.02138	0.19242
Resistors	0.1%	1	0.72	0.72	0.54	0.54
Ceramic Cap	.1UF 50V 10% CER RADIAL	4	0.112	0.448	0.06272	0.25088
Thermistor	0.1% at 25C	1	3.975	3.975	1.9875	1.9875

Total per Unit

\$12.77

\$9.68

Performance

The below graph gives a general understand of the performance to be expected from the above circuits. It is important to understand the conditions for which the graph was generated. The below graph represents the 0-100-output amplification for any Micro IRt/c model circuit. It was assumed that a perfect thermocouple was being connected to the amplification circuit, and that all components were at nominal values. Since the Micro IRt/c accurately simulate a thermocouple in the region of intend use, the accuracy outside of that region will be less.

Amplifier for K type thermocouple 0-100C

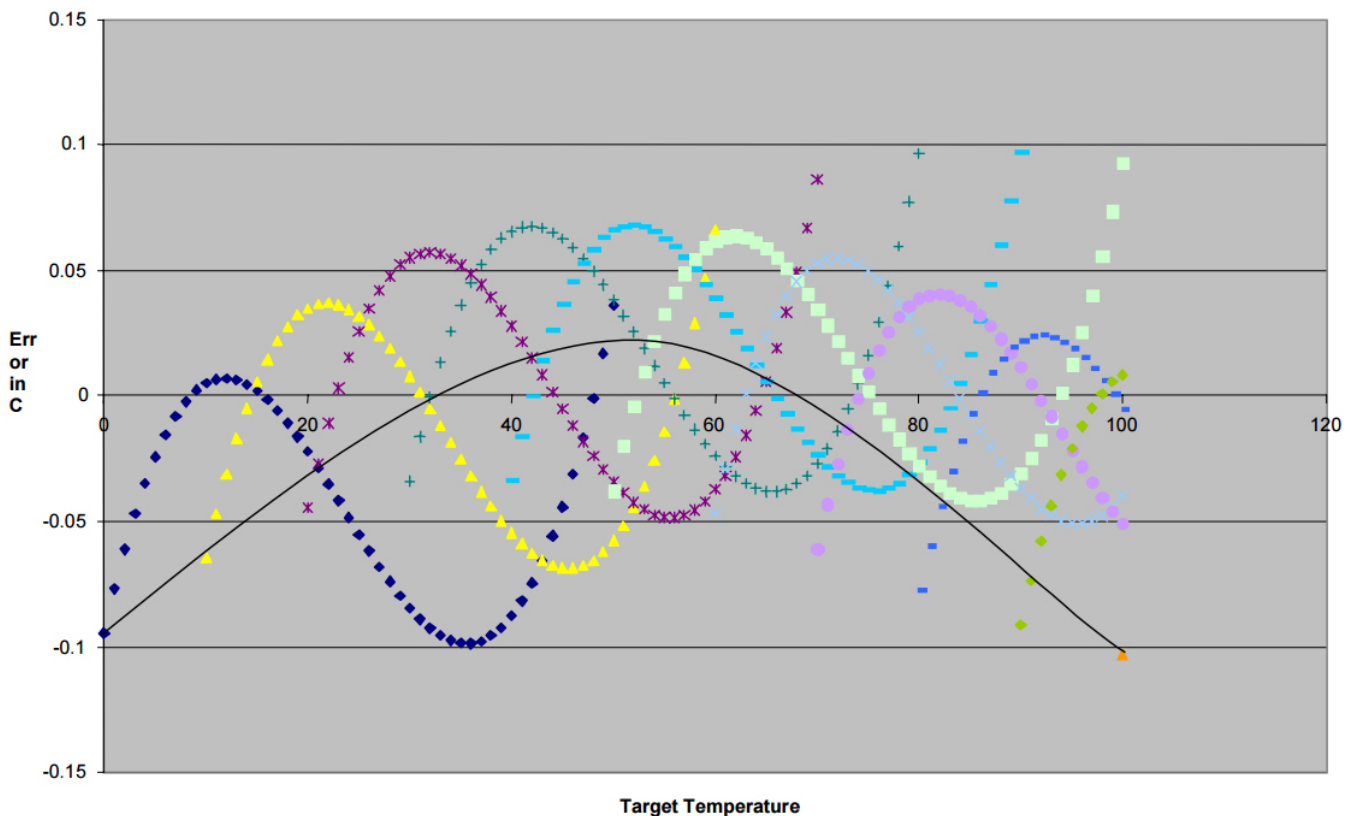

Each line in the graph represents a different combination of Micro IRt/c temperature and cold junction temperature. For each data set, represented by color, the curve you see is generated by the inaccuracy of the cold junction. The shape will be exaggerated when different thermistor or component values are used. The black curve represents the error due to the non-linearity of the perfect thermocouple. When you place an Micro IRt/c into this circuit, this curve changes shape and rate of change.

Closure

We hope that this report at least has you own your way to making an interface for your Micro IRt/c application. As always feel free to contact Exergen Global with additional questions.

Exergen Global offices:

The Netherlands
 Pastoor Clercxstraat 26
 5465 RH Veghel
 Tel: +31 (0)413 376 599
 Fax: +31 (0)413 379 310

USA
 400 Pleasant Street
 Watertown, MA 02472
 Tel: +1 617 649 6322
 Fax: +1 617 923 9911

office@exergenglobal.com
 www.exergenglobal.com